

Premium Laboratory Equipment | Rotary Evaporators

Multifunctional individualists



Don't compromise

Heidolph Premium Laboratory Equipment stands for reliability, precision, and efficiency. Your demand drives us to provide the fastest service, individual support, and quality without compromise. This allows you to focus purely on your research, your company, and the millions of people worldwide.
In short: research made easy.

For us, "Made in Germany" is far more than just a marketing strategy. It is part of our company philosophy.

Our location in Germany allows us to develop and produce reliable laboratory equipment with an average operational lifespan of 10 years or more. For you, this means that every purchase is an investment in the future.

All Heidolph products are developed and manufactured at our Schwabach headquarters in Nuremberg, where they undergo multi-stage quality checks in development and production. Even in continuous operation, our powerful, no-maintenance motors ensure consistent results and prevent downtimes and expensive repairs.

To us, premium service means cost-free installation and training, the shortest possible repair and delivery times and individual expert advice – simply "research made easy".

MADE IN GERMANY

3-year warranty on all devices
and an average operational
lifespan of **10 years**

Multi-stage quality checks in
development and production

Premium service according to
the "research made easy"
principle

Free product-demo!

You can thoroughly test our devices
with a non-binding and free demo to
ensure that our products meet all
your requirements.

Evaporation – unlimited options

Whether you wish to distill small samples for analysis, prepare large batches, or continuous evaporation – the Hei-VAP range has the right solution for every task. For maximum efficiency and precision, we recommend using our complete solutions, including peripheral devices, which are configurable to your application.



Hei-VAP Rotary Evaporators

Leading Safety Standards

All models come with a safety heating bath with handles, pour spout, and cable coupling with protection class IP 67 to prevent short-circuiting and corrosion. The residual heat indicator also alerts you to a temperature above 50 °C when in stand-by mode. In the event of continued temperatures exceeding by >5 °C, the heating is turned off to prevent running dry.

Superior Ease of Use

Simplify your day-to-day work with smart details such as a detachable panel, control knobs for direct control, the Easy-Clip for removing flasks, and the patented vapor tube. All glass accessories such as distillation spiders, evaporating cylinders, or evaporating flasks up to 5 l can be used with the universal 5 l heating bath without retrofitting.

Reduced Cost of Ownership

All components complement each other and are made for years of continuous operation: PTFE vacuum seals, UV resistant tubes with best chemical stability, condensate-repellent varnish, sealed housing, maintenance-free and sparkless motors. FDA compliant materials increase the range of applications without additional accessories.



Operating panel YOUR ADVANTAGES

- Detachable panels allow for changing all parameters from outside closed fume hoods to guarantee the highest safety level
- Immediate access to the panel ensures ultimate control of the process while increasing your ease of use
- A separate on/off switch for heating prevents unintentional heat-up – the button is illuminated for visual control



The patented flask clamp Easy-Clip simply ejects stuck flasks.



No sticking in the drive, no broken glass – the patented clamping sleeve system allows easy removal of the vapor tube from the drive.

Hei-VAP Value/Value Digital Uncompromising quality and simple handling

With this model, you can directly control rotation speed and heating temperature at any time.

- The convenience of large dial controls for adjustment of rotation speed and bath temperature
- Hei-VAP Value Digital models come with a digital display for set and actual heating bath temperature
- Safety heating bath with handles and pour spout will power off if temperature overshoots by 5 °C or runs dry
- A separate on/off switch for heating prevents unintentional heat-up – the button is illuminated for visual control
- Adjust the required angle of the evaporating flask individually according to your needs



Grease-free operation thanks to innovative sealing technology.

Hei-VAC Control
Easily upgrade your Hei-VAP Value/ Value Digital or Advantage model with the new digital vacuum controller for accurate vacuum control of house vacuum systems or any other valve regulated vacuum pump.

Hei-VAP Advantage

Wide range of possibilities for reproducible results

All settings at a glance with the large digital 3.5" LCD display which indicates rotation speed, heating bath and vapor temperature. Take your motorlift advantage: In case of a power cut, motor lift models will remove the flask from the heating bath preventing safety hazards and potential thermal damage to your sample.

- Direct view on all parameter settings due to the large digital 3.5" LCD display
- Compatible with vapor temperature sensor
- Automatic process timer turns off the evaporator at a pre-programmed time and removes evaporating flasks from bath on motor lift models
- Available in hand lift or motor lift configurations



Our new Hei-CHILL range:
Complementary systems for
excellent substance separation.
(see page 11)



Hei-VAP Precision

Maximum capabilities due to integrated vacuum control

The Hei-VAP Precision provides you with the maximum range of parameters, including but not limited to, reproducible applications and fully automated processes. Even solutions with different boiling points can be identified and distilled.

- 4.3" color graphic display features all parameters and included programs for automated distillations
- No need to configure the unit manually – all connected devices will be recognized by the evaporator
- Easily manage even the most demanding applications and prevent foaming, excessive bubbling or bumping
- Up to 30 applications can be saved in a "Favorites" section for individualized pre-programmed parameter settings used on a daily basis
- Comes with an integrated vacuum controller
- Pre-programming vacuum gradients allows for controlling processes individually

From programs for automated distillations up to full automation of evaporation – 24 hours a day/7 days a week.

More information on page 14.



Save time with the automated process control

For automated distillation choose between these three programm opportunities:

System requirements:

The automatic process control requires the AUTO_{accurate}-sensor as well as the configuration with compatible glassware (G3, G3XL or G6).



SET_{pressure}

Program for solvent separations

This program holds a pre-set vacuum constant. During the evacuation you have the full flexibility to choose another level of vacuum by pressing a button. Optionally, the process can be predefined via programmable ramps.

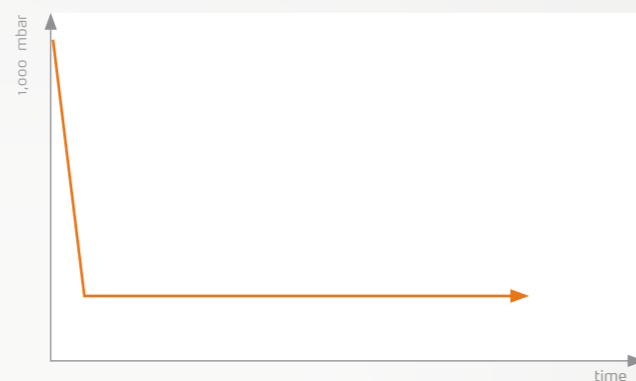

AUTO_{easy}

Supports the automatic pressure control for solvent separations

The pressure level for the first boiling point is found automatically. This program can be used with all Heidolph glassware assemblies and does not require any accessories.

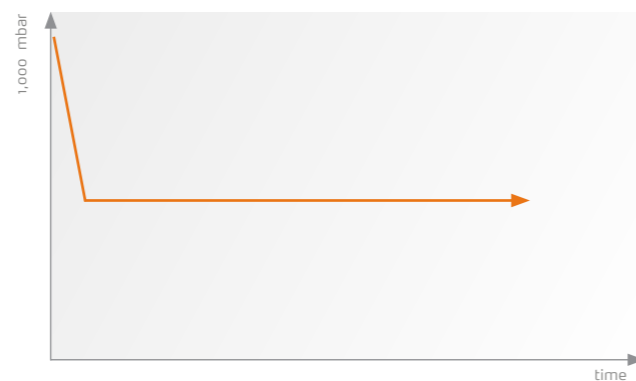

AUTO_{accurate}

Supports very precise automatic pressure control for solvent separations

The boiling points of one or more fractions are identified through the steam temperature gradation of the mixture during continuous automatic pressure control. You can freely set whether one or more fractions are to be distilled. The vacuum control is fully automated for each fraction. The evaporation speed can be controlled by adjusting the ratio of steam temperature to cooling temperature.

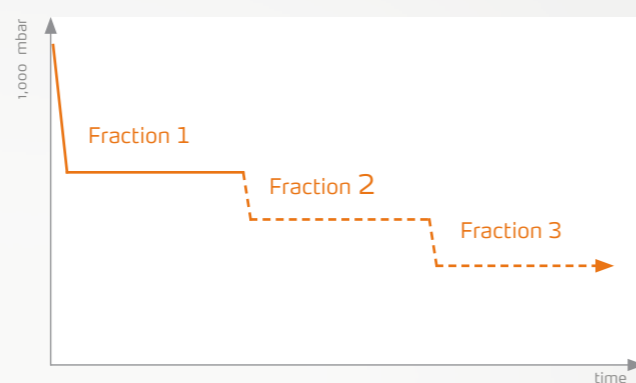

Glassware

All glassware sets include one 1,000-ml evaporating flask and one 1,000-ml receiving flask. Also available with transparent plastic coating for added safety.



XL Condenser

For maximum evaporation performance

The XL condenser with condensing surface of 2,200 cm² achieve up to 40 % higher evaporation rates. Available in G3 XL, G3 B XL and G9 XL versions.

Glassware set G1

Diagonal condenser for all standard distillations; the option with the most affordable price

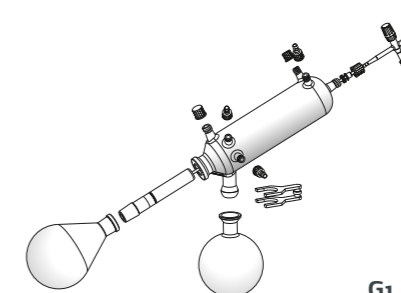

G1

Glassware set G3/G3 XL

Vertical condenser for all standard distillations; the option with the smallest space requirements, also available as XL version

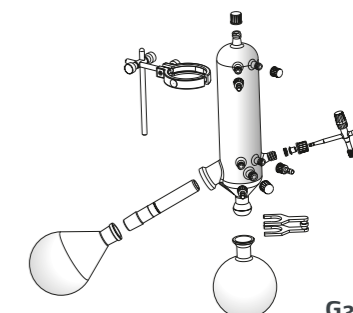

G3/G3 XL

Glassware set G5

Dry Ice condenser for low-boiling solvents

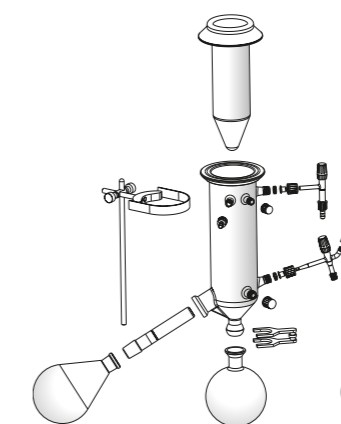

G5

Glassware set G6

Vertical condenser; centerpiece with valve for reflux distillation

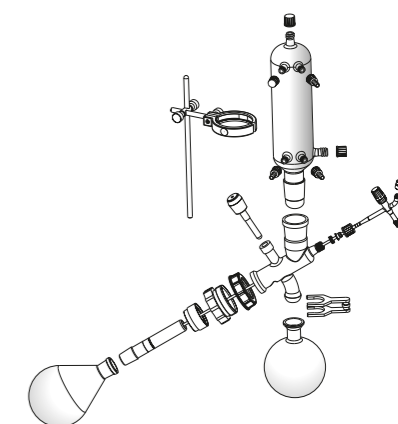

G6

Rotavac Vacuum Pumps

Valve-Regulated Vacuum Pumps

For manual and valve-regulated vacuum control. Suitable for all Hei-VAP models. Can be combined with condenser.



Rotavac Valve Tec

Recommended for solvents in the low to medium boiling temperature range.

Rotavac Valve Control

Sufficient throughput for almost all applications and for up to three rotary evaporators.

RPM-Regulated Vacuum Pumps

Highest distillation rates possible and reducing process time by 30 %

Stable distillation conditions account for solvent recovery up to 99 %ag+

Controllable vacuum pumps for digital regulation of the vacuum via operation panel of the rotary evaporator or directly at the unit.

- Speed adjustment stops completely if vacuum is reached and runs intermittently at very low speed to hold vacuum constant
- Increased diaphragm performance life and less energy consumption due to periods of non-operation
- Most precise vacuum level at all times and significant noise and vibration reduction due to intermittent operation

Fully automatic control with speed adjustment



RPM regulated pumps adjust their speed individually when the required vacuum level is reached.



Rotavac Vario pumping unit

Fully controllable stand-alone pumping unit including vacuum controller.

Rotavac Vario Tec/Control

Models without vacuum controller. Recommended for the configuration with Hei-VAP Precision to digitally regulate the vacuum via operation panel.

Hei-CHILL Recirculating Chillers

The Hei-CHILL models are specifically designed for reliable continuous operation in the laboratory offering cooling capacities of 250 to 1,200 W. The magnetic coupling of the pump and electric motor prevents leakages at the pump shaft.

Easy to use:

- Clearly arranged control elements, large LED display, membrane keypad, and window for monitoring the tempering liquid level
- With a large coolant reservoir to compensate for peak performance during the evaporation process



	Hei-CHILL 250 1	Hei-CHILL 350 2	Hei-CHILL 600 3	Hei-CHILL 1200 4
	The compact design fits effortlessly on a laboratory bench		With rollers for placement under a lab bench	
Cooling capacity at 20 °C	250 W	350 W	600 W	1,200 W
Operating temperature range	-10 to +40 °C	-10 to +40 °C	-10 to +40 °C	-10 to +40 °C
Temperature stability	±0.5 K	±0.5 K	±0.5 K	±0.5 K
Pump pressure max.	0.35 bar	0.35 bar	1.3 bar	1.3 bar
Pump flow max.	9 l/min	9 l/min	20 l/min	20 l/min
Filling volume	2 to 4 l	4 to 7 l	4 to 8 l	7 to 14 l
Measurements l/w/h	200/350/465 mm	240/400/500 mm	350/480/595 mm	450/550/650 mm

Hei-VAP Large-Scale Rotary Evaporators

Leading Safety Standards

The safety glass in the protective hood of the evaporating flask, and the PMMA safety screens covering the glass set and cassettes of the receiving flask, protect against shards in the event of an implosion. The operating panel displays all safety-relevant functions that must be met at start-up. In the event of excess pressure or excess temperature, the system turns off the relevant functions. A sensor checks the fill level at immersion into the heating bath to prevent overfilling.

Superior Ease of Use

Intuitive touch display for monitoring all parameters and functions for program-controlled distillation. Can be safely and easily operated by a single person: EASY LOCK flask attachment with adjustable tray for all evaporating flask sizes up to 20 liters, drain valves at the receiving flasks, automatic water bath refill system, and optional fully-maneuverable base cart.

Reduced Cost of Ownership

The complete glassware and all accessories such as vacuum controller, vacuum valve, vacuum sensor, and vapor temperature sensor are included with delivery. Water or oil – the universal heating bath can be used for both. The unique tightness of the system increases the flow capacity while decreasing energy consumption at the same time.

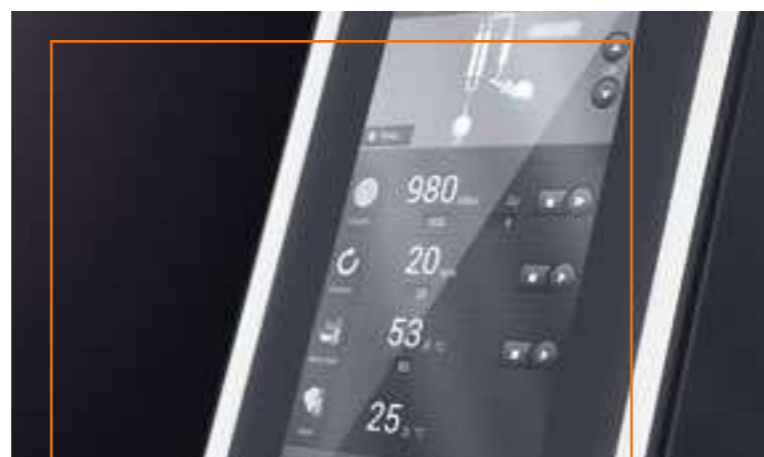

Hei-VAP Industrial YOUR BENEFITS

- With integrated vacuum controller and clearly arranged touch display for intuitive definition of all process parameters
- Safety features prevent accidental start-up of the process
- Smart details ensure easy and safe operation even by a single person on their own

TIP: Processes can be fully automated in combination with the automatic module Distimatic with automatic residue drainage. For unlimited, continuous distillation during unsupervised continuous operation all day, every day, 24/7.

Hei-VAP Industrial

Process large volumes easily and safely

Large scale Hei-VAP rotary evaporators can be operated in batch operations with flask sizes up to 20 liters. The many safety features and easy operation allows for safe user interaction and convenience – even with one operator. Our application consultants can advise you on process optimization techniques as well as configuring a perfect all in one package.



- Change flasks safely and simply with the EASY LOCK flask attachment
- Intuitive touch display with an overview of all parameters
- With timer, ramp function, and two programs for process control: SET_{pressure} and AUTO_{accurate}
- Fully equipped, including glassware, vacuum controller, vacuum valve, and vacuum and vapor temperature sensor
- Outstanding safety features, both on the housing as well as via the safety features on the touch display
- More time through excellent efficiency – with the automatic module Distimatic, even unsupervised continuous operation is possible all day, every day

Maximum performance with systems that perfectly complement each other. Discover the Hei-CHILL range at www.heidolph.com



Hei-VOLUME Automatic Modules

Leading Safety Standards

The automatic module Distimatic allows for the full automation of rotary evaporators from the Hei-VAP range, both for the 5 l benchtop or the 20 l large-scale rotary evaporator. Sensors monitor the complete process and shut down the attached peripheral devices in an emergency. The system can also be operated in closed laboratory hoods.

Superior Ease of Use

Unlimited amounts in continuous operation, fully automated and unsupervised distillation: with automatic refill, discharge of condensate, and automatic residue drainage for nearly complete separation. Sensor- or time-controlled program automation for automatic distillation and adjustable parameters for exact calibration allow for an extensive range of applications.

Reduced Cost of Ownership

Maximum efficiency – complete automation of the process saves valuable time. Depending on the selected program, the process is stopped automatically after evaporation of the mixture or after the intervals are complete.

Hei-VOLUME Distimatic

Simply smart – automatically process unlimited amounts

Thanks to the unique automatic residue drainage of the automatic module Distimatic, you can distill unlimited amounts in unsupervised continuous operation. 24 hours a day, 7 days a week. This turns rotary evaporators into automated stations.



Simple process optimization with regards to efficiency and precision:

- Automatic refill of the base mixture, discharge of the condensate and drainage of residue
- Outstanding evaporation rates in automated, unsupervised continuous operation
- Degree of concentration for final product can be determined to rule out dehydration, crystallization and formation of powder
- Bumping is eliminated by continuously feeding small volumes
- Storage and collecting tanks can be replaced during the process
- Uninterrupted process monitoring through sensors, including complete emergency shut-down of the system

The automatic module Distimatic is compatible with all Hei-VAP rotary evaporators and large-scale rotary evaporators.

Technical Specifications

Rotary Evaporators

Rate of evaporation ⁴	Toluene	Acetone	Ethanol	Isopropanol (IPA)	Water
G3 Vertical	6.5 l/h	6.0 l/h	2.5 l/h	4.0 l/h	1.4 l/h
G3 XL Vertical	8.5 l/h	7.5 l/h	3.5 l/h	4.9 l/h	1.4 l/h
Improvement with XL Condenser	31 %	25 %	40 %	23 %	system limit reached with 1.4 l/h

Model	Hei-VAP Value/Value Digital (HL)	Hei-VAP Advantage (HL)	Hei-VAP Advantage (ML)	Hei-VAP Precision (HL)	Hei-VAP Precision (ML)
Lift	hand lift	motor lift	motor lift	hand lift	motor lift
Height adjustment speed	manual	manual	30 mm/s	manuell	30 mm/s
Height adjustment	155 mm	155 mm	155 mm	155 mm	155 mm
Rotation speed	10–280 rpm	10–280 rpm	10–280 rpm	10–280 rpm	10–280 rpm
Rotation speed setting	skale	3.5" LCD display	3.5" LCD display	4.3" LCD color graphic display	4.3" LCD color graphic display
Drive	brushless DC motor with electronic speed control				
Heating capacity	1,300 W	1,300 W	1,300 W	1,300 W	1,300 W
Temp. range heating bath	20–210 °C	20–210 °C	20–210 °C	20–210 °C	20–210 °C
Temperature accuracy bath	±1 °C	±1 °C	±1 °C	±1 °C	±1 °C
Overheat protection bath	cut-off at 5 °C over set temperature via separate Pt 1000				
Bath temperature setting¹	skale/digital	3.5" LCD display	3.5" LCD display	4.3" LCD color graphic display	4.3" LCD color graphic display
Heating bath temperature control	electronic/digital	electronic/digital	electronic/digital	electronic/digital	electronic/digital
Secondary overtemp. cut-off	250 °C	250 °C	250 °C	250 °C	250 °C
Material heating bath	stainless steel AISI 316 L				
Diameter heating bath	255 mm	255 mm	255 mm	255 mm	255 mm
Volume heating bath	4.5 l	4.5 l	4.5 l	4.5 l	4.5 l
Max. size evaporating flask	5 l	5 l	5 l	5 l	5 l
Display vapor temperature required accessories	–	yes vapor temperature sensor	yes vapor temperature sensor	yes vapor temperature sensor	yes vapor temperature sensor
Integrated vacuum controller	–	–	–	yes	yes
Timer	–	yes	yes	yes	yes
Vacuum program SET_{pressure}²	–	–	–	yes	yes
Vacuum program AUTO_{easy}²	–	–	–	yes	yes
Vacuum program AUTO_{accurate}² requires AUTO_{accurate}-sensor	–	–	–	yes	yes
Remote control function	start rotation start heating bath	start rotation start heating bath	lift start rotation start heating bath	start rotation start vacuum start heating bath	lift start rotation start vacuum start heating bath
Programmable ramps	–	–	–	yes	yes
Supply power	1,400 W	1,400 W	1,400 W	1,400 W	1,400 W
Weight w/o glassware assembly	16 kg	16 kg	16 kg	17 kg	17 kg
Dimensions with glassware set G3	max. w/d/h 477 × 739 × 845 mm	477 × 739 × 845 mm	407 × 739 × 845 mm	523 × 739 × 845 mm	453 × 739 × 845 mm
Dimensions with glassware set G3 XL	max. w/d/h 477 × 739 × 920 mm	477 × 739 × 920 mm	407 × 739 × 920 mm	523 × 739 × 920 mm	453 × 739 × 920 mm
Condensing surface	1,400 cm ²	1,400 cm ²	1,400 cm ²	1,400 cm ²	1,400 cm ²
Condensing surface XL condenser	2,200 cm ²	2,200 cm ²	2,200 cm ²	2,200 cm ²	2,200 cm ²
Permissible ambient conditions	5–31 °C at 80% rel. humidity, 32–40 °C decreasing linearly up to max. 50% rel. humidity				
Protection class³	DIN EN 60529 IP 20	IP 20	IP 20	IP 20	IP 20

¹ Hei-VAP Value Digital: digital display

² Only in combination with vacuum systems

³ IP 67 cable connection on heating bath

⁴ With maximum condenser efficiency

Standard supply voltage: 230 V. Other voltages upon request, please specify for order.

Technical Specifications

Large-Scale Rotary Evaporators

Model	Hei-VAP Industrial	
Rotation speed	6–160 rpm	
Rotation speed setting	digital	
Display	7" touch display	
Lift	motor lift	
Height adjustment speed	45 mm/s	
Height adjustment	180 mm	
Drive	EC-motor	
Heating capacity	4,000 W	
Temperature range heating bath	20–180 °C	
Temperature accuracy	±1 °C	
Overheat cut-off protection	110 (H ₂ O)/210 (oil)	
Bath temperature setting	digital	
Automatic heating bath control	micro processor	
Material heating bath	stainless steel AISI 316 L	
Diameter heating bath	400 mm	
Volume heating bath	24 (H ₂ O)/22 (oil)	
Level regulation of water bath	automatically due to level sensor and refill function	
Display vapor temperature required accessories	digital temperature sensor	
Indicating range vapor temperature sensor	0–200 °C (accuracy 0.1 °C)	
Integrated vacuum controller	yes	
Timer	yes	
Vacuum control program SET _{pressure} ²	yes	
Vacuum control program AUTO _{accurate} ² requires AUTO _{accurate} -sensor	yes	
Programmable ramps	yes	
Supply power	4,600 W	
Weight w/o glass assembly	approx. 120 kg	
Dimensions	w/d/h 970×690×1,600 mm	
Rate of evaporation ¹ at 40 °C temperature difference	Toluene 26.0 l/h Acetone 25.9 l/h Ethanol 12.9 l/h Water 4.7 l/h	
Maximum condensing surface	1.2 m ²	
Permissible ambient conditions	5–31 °C at 80% rel. humidity, 32–40 °C decreasing linearly up to max. 50% rel. humidity	
Protection class	DIN EN 60529	IP 20

Standard supply voltage: 400 V three-phase current. Other voltages upon request, please specify for order.

¹ ΔT = difference between heating bath temperature and boiling temperature

² Only in combination with vacuum systems

Technical Specifications

Automatic Moduls

Modell	Distimatic Bench-top without drainage of residue	Distimatic Bench-top including drainage of residue
Compatibility Rotary Evaporators	Hei-VAP and Laborota 4000 series ³	Hei-VAP and Laborota 4000 series ³
Separate control panel	yes	yes
Display	digital	digital
Automatic refill of sample	yes	yes
Automatic discharge of condensate	yes	yes
Automatic drainage of residue	–	–
Power input control box	50 VA	50 VA
Noise level	< 80 dB (A)	< 80 dB (A)
Total power multiple switched socket	3,500 W	3,500 W
Weight	5 kg	5 kg
Measurements w/o mounted components	w/d/h 300×120×200 mm	w/d/h 300×120×200 mm
Permissible ambient conditions	5–31 °C at 80% rel. humidity, 32–40 °C decreasing linearly up to max. 50% rel. humidity 0–2,000 m a.s.l., Contamination level 2, Overvoltage category II	5–31 °C at 80% rel. humidity, 32–40 °C decreasing linearly up to max. 50% rel. humidity 0–2,000 m a.s.l., Contamination level 2, Overvoltage category II
Protection class	DIN EN 60529 IP 54	IP 54

Modell	Distimatic Industrial without drainage of residue	Distimatic Industrial including drainage of residue
Compatibility (Rotary Evaporators)	Hei-VAP Industrial and Laborota 20 series	Hei-VAP Industrial and Laborota 20 series
Separate control panel	yes	yes
Display	digital	digital
Automatic refill of sample	yes	yes
Automatic discharge of condensate	yes	yes
Automatic drainage of residue	–	yes
Power input control box	50 VA	50 VA
Noise level	< 80 dB (A)	< 80 dB (A)
Total power multiple switched socket	3,500 W	3,500 W
Weight	5 kg	5 kg
Measurements w/o mounted components	w/d/h 300×120×200 mm	w/d/h 300×120×200 mm
Permissible ambient conditions	5–31 °C at 80% rel. humidity, 32–40 °C decreasing linearly up to max. 50% rel. humidity 0–2,000 m a.s.l., Contamination level 2, Overvoltage category II	5–31 °C at 80% rel. humidity, 32–40 °C decreasing linearly up to max. 50% rel. humidity 0–2,000 m a.s.l., Contamination level 2, Overvoltage category II
Protection class	DIN EN 60529 IP 54	IP 54

All shown values relate on Automatic Module Disitmatic without any external accesory parts.

³ To check the compatibility please contact your dedicated Heidolph contact person.

Discover our rotary evaporators at
www.heidolph.com



Heidolph Instruments GmbH & Co. KG
Walpersdorfer Str. 12 • 91126 Schwabach
Phone: +49 91 22/99 20 19
Fax: +49 91 22/99 20 65
E-Mail: sales@heidolph.de

 **heidolph**
research made easy