



Atlas HD



SYRRIS
Atlas HD

Product information

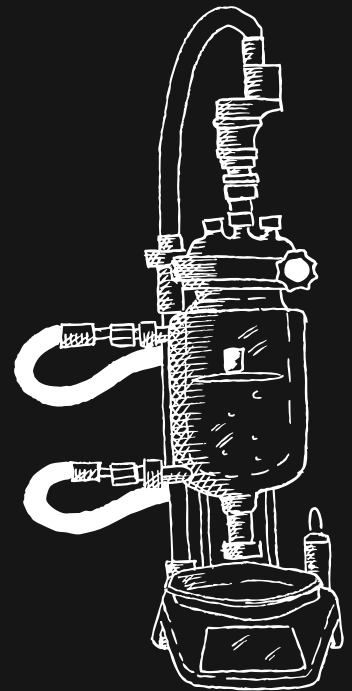

Fast, scalable, reproducible chemistry
with full automation

Atlas HD

Atlas HD is an automated and modular jacketed reactor system for R&D chemists and chemical engineers. Atlas HD enables supreme flexibility and easy cleaning with tool-free vessel changes from 50 mL to 5 L.

Atlas HD can be tailored to your chemistry needs with a temperature range of -90 to +250 °C, various stirring options, and a wide range of pressures.

A range of sensors including turbidity, temperature, pressure, and pH can be configured. Automated dosing is possible using the intelligent Atlas Syringe Pump.

Enjoy fast, scalable, and reproducible chemistry with Atlas HD.

syrris.com/atlas-hd



What are jacketed reactors?

Jacketed reactors are typically glass or stainless steel reaction vessels that are designed for accurately controlling the temperature of their contents through the use of a “jacket” of heating/cooling fluid.

Round-bottom flasks have long been the mainstay of almost all chemistry labs, but they come with inherent problems that make them unsuitable for more challenging chemistry. Whereas round-bottom flasks are generally limited to 4 temperatures—reflux, room temperature, 0 °C, and -78 °C—the jacketed reactor is controlled by a circulator and provides pinpoint accuracy in temperature control at whatever temperature your chemistry requires.

Automated jacketed reactors

When combined with software automation, jacketed reactors offer far more benefits than just accurate temperature control.

Chemists can program simple or complex reaction recipes to automatically run their reactions without the need for supervision, including the ability to perform temperature and/or pH dependent dosing when combined with intelligent syringe pumps and relevant sensors.

TOP 5 BENEFITS OF CHEMISTRY AUTOMATION

Read more at syrris.com/benefits-of-automation



Increased productivity

Automate your manual tasks, create recipes and run your experiments while you carry out other tasks.



Reliability of results

Remove human error, increase reproducibility and reliability with easy to understand graphical data to ensure you get the best possible chemistry.



Improved safety

Set software limits that allow the system to shut down automatically if conditions are exceeded, and set alarms to warn you when there is a risk of an accident.



Resource savings

Chemistry automation increases productivity and reaction accuracy, helping your lab perform more chemistry, minimize reagent wastage, and improve experiment efficiencies.



Walk-away time

Intelligent software automatically performs your chemistry for you while you get away from the lab bench to catch up on those publications you've been meaning to read!

Features

Powerful stirring

Quick-release high speed stirrer motor and coupling. The Scorpion Overhead Stirrer provides auto-aligning overhead stirring up to 800 rpm

Oil Pipe Tidy

To allow leak-free storage of your oil pipes when changing vessels. The Oil Pipe Tidy is easily attached to the Scorpion Pole on the Atlas HD Base Frame

Oil Drain Unit

The perfect accessory for those wishing to change vessels with as little fuss and mess as possible. The Oil Drain Unit provides the ability to quickly drain oil from a Jacketed Reactor Vessel back into a recirculator without exposure to the oil

Spring-loaded bottom outlet valve

Syrris' spring-loaded outlet valves ensure leak-free operation at all temperature ranges and prevent breakages from over-tightening

Data logging and graphical display

Automated data logging ensures safe keeping of data. Real-time graphing of all data streams allows quick monitoring of reaction parameters

Probes and Nodes

Temperature, turbidity, and pressure. Atlas HD probes and nodes can be used in conjunction with the Atlas Syringe Pump for temperature-controlled and pH-controlled dosing

Quick clamp release

The Jacketed Vessel Clamp is a quick-release clamping mechanism. Designed to make changing reactors both quick and easy, the clamp supports the vessel even when fully open

Vessels and lids

Choose from a range of handmade borosilicate glass jacketed reaction vessels and lids. Available in round bottom and torispherical profiles with vacuum jacketed options for torispherical vessels

Range of stirrers

Stirrers are available in anchor, Pitched Blade Turbine, and retreat curve impellor as standard. Custom options are also available, as well as adjustable impellers

Touchscreen control base

The touchscreen base provides full reaction automation directly on Atlas HD

Applications

Thanks to its modular design, Atlas HD is easily customized for a wide range of chemistries.

Advanced Synthesis

Atlas HD is designed to operate complicated synthesis with multiple dosing profiles and PAT feedback. High temperature to cryogenic temperatures can be achieved.

Reaction Calorimetry

The Atlas HD Reaction Calorimeter has been designed to be the easiest reaction calorimeter on the market to use and understand. Offering both Heat Flow Calorimetry (HFC) and Power Compensation Calorimetry (PCC), the system is perfect for the understanding of your thermal hazards.

Crystallization

Atlas HD Crystallization controls and monitors the crystallization process by automatically modifying temperature and dosing to the vessel in real-time. Crystal growth is monitored using a turbidity probe.

Ultrasound technology allows reproducible control of crystallizations, enabling selectivity of parameters such as particle size, shape, crystallinity, and polymorphism.

Pressure Reactors

Atlas HD 3 Bar designed for applications where elevated pressures are required, such as hydrogenations, carbonylations, etc., or high-vacuum applications.

The Atlas 200 Bar Pressure System* is designed for applications where elevated pressures up to 200 bar are required, such as hydrogenations, carbonylations, etc.

*This system uses the Atlas Classic base with clickwheel control



Accurate reaction control

Atlas HD's touchscreen and PC software provides you with unmatched capability to accurately and automatically define and control various reaction parameters over a range of working volumes.

With the ability to control other lab equipment—such as the Atlas Syringe Pump—Atlas HD provides you with full walk-away chemistry, relieving you of mundane reaction monitoring and freeing up your time to focus on more interesting tasks.

With built-in safety features including alarms and shutdown policies, you can confidently let your reactions run overnight or even over weekends!

Atlas HD automatically logs all reaction parameters which are displayed graphically both in real time and for post-reaction analysis. You can easily recall and replicate experiments, ensuring complete repeatability of your processes.

Take complete control of your reactions with Atlas HD's intuitive, powerful, and easy-to-use touchscreen and PC software.



Atlas Syringe Pump

Atlas Syringe Pumps are versatile chemistry pumps featuring advanced dosing protocols including pH control, temperature-dependent dosing, and autosampling, with flow rates from 0.5 μL to 200 mL/min. Atlas Syringe Pumps are perfect for chemists looking for a single syringe pump that can fulfill all their chemistry needs.

Multiple dosing options, including;

- Temperature-dependent dosing
- pH-controlled dosing
- Autosampling of up to 6 samples with each syringe/valve

Multiple control modes, including;

- Dual Dosing Mode provides two independent dosing channels
- Continuous-Dosing Mode combines both dosing channels to provide a single continuous flow
- Autosampling Mode allows one reagent to be dosed while collecting samples from the process at predefined times

Temperature-dependent dosing

Accurate temperature control and monitoring is vital for accurately predicting the scale-up of chemical processes, and in biochemistry, temperature control is critical to avoiding denaturing or damaging the product.

Atlas Syringe Pumps offer temperature-dependent dosing whereby the reagent addition is automatically paused until your safe reactor temperature is reached. This enables you to automatically mitigate against exotherms and endotherms, increasing laboratory safety and saving valuable time.

pH-controlled dosing

Combined with an Atlas pH probe and node, the Atlas Syringe Pump can automatically dose an acid and/or base to keep the pH of your reaction within a defined range. Automated pH control can save chemists valuable time by removing the need to manually add small amounts of acid/base over the course of a reaction.

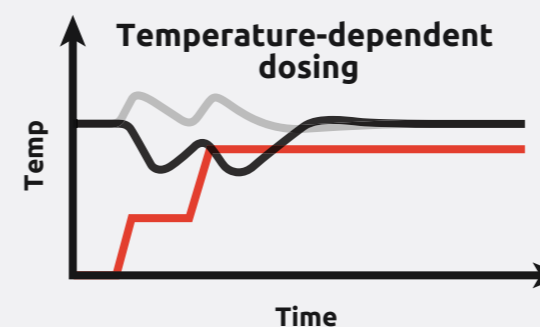

■ Temperature Probe ■ Circulator Temperature ■ Dosed Volume

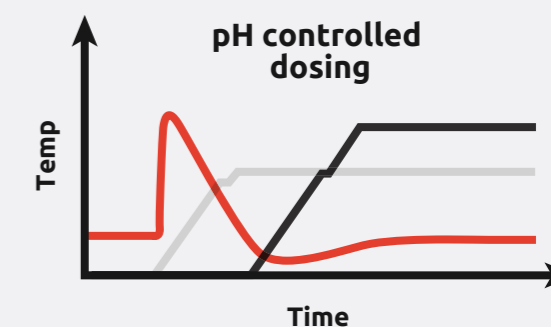

■ Syringe A: Sulfuric Acid ■ Syringe B: Sodium Hydroxide ■ pH Meter

Case Study

Walk-away process development for API production with Atlas HD

Scott Clunas, Process Chemist
TauRx Therapeutics

Researchers at TauRx Therapeutics are using the automation capabilities of the Syrris Atlas HD reactor systems to simplify and accelerate process development for its product pipeline. Based at the company's primary research facilities at the University of Aberdeen, Scotland, the Syrris equipment is an integral part of the quality by design (QBD) process optimization workflow. Process Chemist Scott Clunas explained:

"We have been using Syrris' Atlas Syringe Pumps and software for a number of years. This combination of pumps and automation software is very flexible, allowing us to add multiple reagents to a reactor vessel at set intervals, without needing to have somebody at the bench to manually add liquids or swap lines. We have been very happy with the robustness and performance of the pumps, so when we were looking to invest in

additional batch reactor systems, Syrris was the logical choice.

"We now have four Atlas HD jacketed reactor systems—set up as two parallel pairs each controlled by a single PC—allowing us to more quickly and easily perform QBD studies for the production of our active pharmaceutical ingredients. Each of these experiments can run for 24 to 48 hours, so it's essential that we can automate the entire reaction.







"The Atlas reactor systems ensure that each experiment is performed in exactly the same way every time—eliminating the variability associated with manual processes—giving us a very high degree of process control for consistent results and, ultimately, more robust processes."

Accessories

Atlas HD has been designed to overcome the issues chemists face in a Process Development lab. Atlas HD provides ultimate ease-of-use, intelligent automation and monitoring, and complete system flexibility. Choose from a range of vessels, probes, sensors, stirrers, and more to have complete control of your processes.

Jacketed reactors

Choose from a range of glass jacketed and vacuum jacketed reaction vessels. All Syrris reactor vessels are manufactured at our state-of-the-art glass manufacturing site.

	Round Bottomed	100 mL to 5 L
	Torispherical	50 mL to 2 L
	Vacuum Jacketed	100 mL to 5 L
	Conical Bottom	250 mL to 1 L
	Stainless Steel (Torispherical)	100 mL to 2 L
	Custom reactors are also available	

Lids





Atlas HD lids are available in borosilicate glass, PTFE, and stainless steel in various sizes: DN80 (EU and US) and DN150 (EU and US). **Custom lids are also available.**

Probes and Nodes







Wide range of probes and nodes available in various lengths, including temperature, turbidity, and pH. Atlas HD probes and nodes can be used in conjunction with the Atlas Syringe Pump for temperature-controlled and pH-controlled dosing.

Stirrers

PTFE, glass, and stainless steel stirrers in a variety of geometries are available.

	Anchor
	Pitch blade turbine
	Retreat curve impellor
	Custom stirrers are also available

Specifications

	Vessel range	50 mL to 5 L
	Temp. range	-90 to 250 °C*
	Pressure range	Vacuum: ≤50 mbara. Max. pressure: 200 bar**
	Stirrer motor rpm	800 rpm
	Stirrer motor torque	11 Ncm***
	Dosing options	0.5 µL to 20 mL/min (Atlas Syringe Pump) 5 µL to 200 mL/min (Atlas XL Syringe Pump)

Dimensions

	h (mm)	w (mm)	d (mm)
DN80 System (50 mL to 2 L)	1230	540	470
DN150 System (1 L to 5 L)	1330	580	470
Atlas Syringe Pump	255	163	240
Atlas XL Syringe Pump	355	163	258

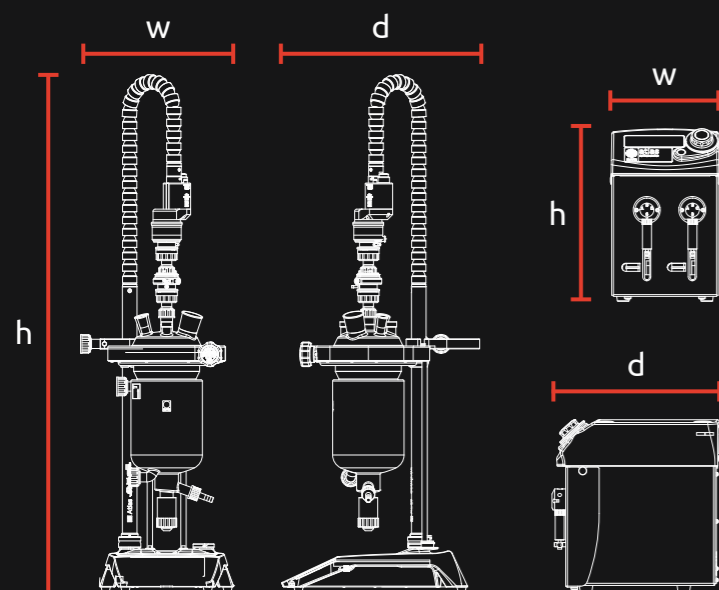

* Normal temperature range is -40 to 200°C. Temperatures outside of this range require an upgrade kit.

** Atlas HD Potassium: Vacuum (≤50 mbar) to 250 mbar. Lower vacuum is achievable with upgraded parts

Atlas HD 3 Bar: Vacuum (≤1 mbar) to 3 bar

Atlas Sodium 200 Bar (Stainless Steel): Vacuum (≤1 mbar) to 200 bar

*** High torque motors available

All dimensions in mm. Please allow a tolerance of +/- 20 mm.

Why choose Syrris?

Custom parts

We understand that all labs are different, so while we've designed our products to be as flexible as possible, sometimes you'll need something unique to your laboratory or application.

Many custom parts are simple variations on existing parts—shorter stirrer shafts or extra ports on a lid, for example. Some customers, however, require far more complex custom parts for their jacketed reactors or flow chemistry systems, such as automated bottom outlet valves (BOVs), unique stirrer designs, or custom vessels.

Syrris' ability to create unique custom parts is one of the main reasons chemists around the world choose Syrris for their needs.

Support

Syrris is on hand to help when you need it. From feasibility studies and proof of concept, through to on-site support by a Syrris engineer, our team are experienced chemists and are supported by a network of trained distributors in over 40 countries.

Built by our UK production team to the highest standard, with chemically resistant materials, Syrris products ensure years of continued service. A 1-year warranty as standard and the option to extend this further for complete peace of mind.

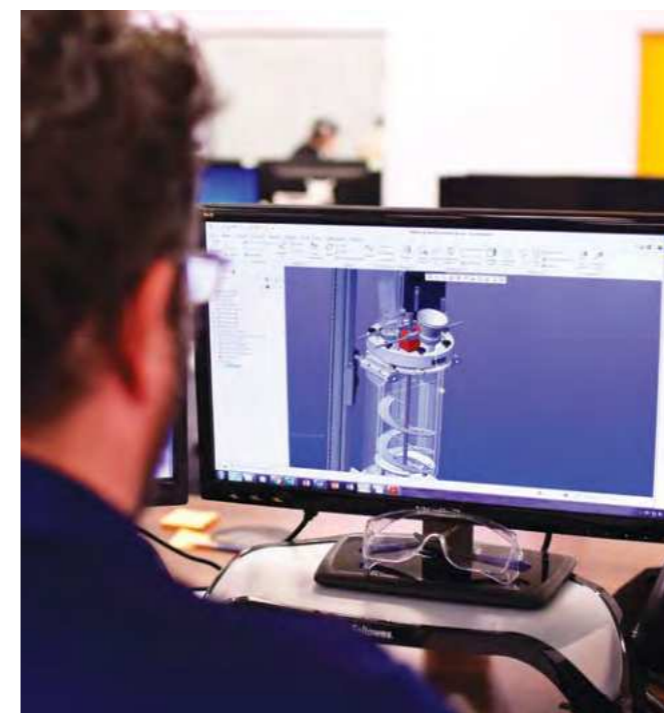

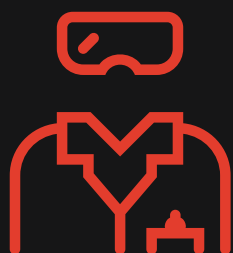

// With Atlas, we can leave experiments running all night and get a good result the next day, freeing up time to do other tasks. The system is easy to use and reliable"

Onofre Casanova, IFF, Benicarlo, Spain

// We have been delighted at the high demand our chemists have placed on Atlas. We are also very impressed with the speed and quality of the service and support"

Dr. Phil Peach, Process CRD, Pfizer, UK

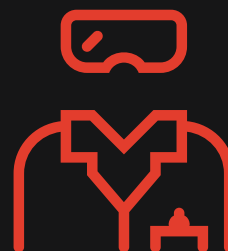

400

Publications

Syrris products have been cited in over 400 peer-reviewed publications, demonstrating their viability for real-world chemistry

40

Distributors

Syrris works in partnership with over 40 distributors worldwide, offering expert knowledge and local support

1000s

of Users

Thousands of chemists and chemical engineers use Syrris products in their ground-breaking research and development, including at the world's top 20 pharmaceutical, chemical, and food and fragrance companies

Get in touch

UK Head Office (Europe, S.E. Asia, Australasia, China, Middle East, Africa)

t: +44 (0)1763 242555
e: info@syrris.com
w: syrris.com

Japan Office

t: +81 45 263 8211
e: info@syrris.co.jp
w: syrris.co.jp

India Office

t: +91 22 256 00 262
e: info@syrris.com
w: syrris.com

North America Office

t: +1 (617) 848 1211
e: info-usa@syrris.com
w: syrris.com

Hanoi Office

t: +84 (0)24 66553474
e: info@syrris.com
w: syrris.com