

DULCO flex Control DFYa

Peristaltic pump

The peristaltic pump DULCO flex Control - DFYa combines the properties of top products from the ProMinent product range.

The valveless peristaltic pump DULCO flex Control - DFYa guarantees precise, linear and reproducible metering in all process conditions. It meters gaseous, viscose, shear-sensitive media, possibly containing particles, with ease – ProMinent is therefore setting new standards in metering with peristaltic pumps.

- Capacity range
5.5 – 410 l/h, up to 8 bar
- Operation by contact, batch, manual, analogue or BUS control
- Adjustment of the metering rate directly in l/h or gph
- Connection to process control systems via a BUS interface, such as PROFIBUS®, Profinet or CANopen
- No problems with very gaseous media or air locks
- Simple, menu-guided hose change
- Reversible direction of rotation
- Suitable for viscosities of up to 40,000 mPas



DULCO flex Control DFYa

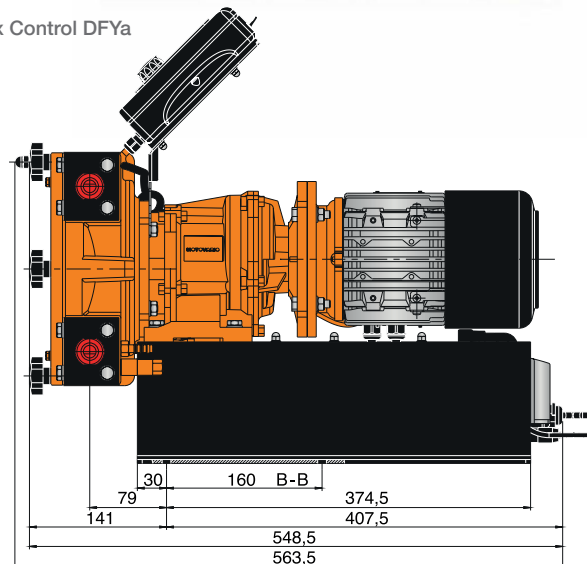

Pump type	Pump capacity bar	I/h	Speed rpm	Suction lift mWS	Priming lift mWS
DULCO®flex Control DFYa					
08410	8	5.5 - 410 ± 10 %	80	8	8
04410	4	5.5 - 410 ± 10 %	80	8	8
02410	2	5.5 - 410 ± 10 %	80	8	8