



Extraction Solutions

Fastest extraction with flexible applications



BUCHI FatExtractor
E-500

Time to end: 50K, 1
Process

<input checked="" type="checkbox"/>	<input checked="" type="checkbox"/>	<input checked="" type="checkbox"/>	<input checked="" type="checkbox"/>	<input checked="" type="checkbox"/>
0	0	0	0	0

Extraction
0:01 min 30:00 min 11 11

Rinse
0:02 min 5:00 min 11 11

Drying
0:00 min 15:00 min 11 11

STOP X [] [] [] []

BUCHI

Fast and Flexible

Fulfill any extraction demand in the blink of an eye

BUCHI offers dedicated extraction solutions for fat determination, as well as for residue and contaminant analysis in various matrices. We cover the entire range of automated extraction methods. Our solutions allow for perfect workflow integration, thus minimizing manual steps.



Powerful and fast extraction

High-tech components and synchronized processes

The use of a fully automated extraction system ensures unattended operation which saves labor time and costs. The combination of high-speed heating elements, specially designed glassware, and an optimized process control system allows for a fast, reproducible extraction procedure that is fully compliant. Full visibility of the processes including pre-set methods, a comprehensive solvent library, and intuitive navigation all facilitate your every-day work.



Safety maximized for you and your analytes

Meet the highest safety standards

Our specially designed sealing system in combination with our high performance condensers ensure minimal solvent exposure and high solvent recovery rates (> 90 %), resulting in safe and environmentally friendly extractions. Permanent monitoring of heaters, cooling water and solvent levels enables perfect user protection and smooth processes. The patent pending analyte protection sensor prevents the deterioration of heat sensitive analytes.



Maximized flexibility

Choose from various extraction methods to suit your requirements

Adapt your FatExtractor E-500 to changing requirements with the interchangeable glass assembly SOX-HE-ECE and execute extractions according to Soxhlet, Randall or Twisselmann. The UniversalExtractor E-800, with the all in one universal extraction chamber has the ability to run up to five different extraction methods simultaneously on each of its six sample positions. This increases sample throughput and allows rapid method optimization.

Effortlessly master your everyday tasks

Extraction Solutions

Dedicated extraction solutions for the determination of fat, for residue and contaminant analysis in various matrices, as well as for any other solvent extraction of materials for R&D or quality control.

Food and Feed Total fat determination



Food and Feed Crude fat determination



Application

- Labeling and quality control
- Reference method for NIR calibrations
- Acid hydrolysis as a mandatory step prior to extraction to obtain the total fat content

- Quality control
- Hydrolysis is not required by regulations
- Hydrolysis is not applied due to the sample's characteristics

Needs

- Accurate and reproducible results
- High sample through-put with minimal user intervention
- Fully compliant with standard methods

- Low cost per sample as the amount of consumables and solvent are optimized
- Synchronized processing of six samples in parallel leads to unprecedented sample throughput
- Easy-to-use instrument with intuitive navigation

Solution

FatExtractor E-500

HydroEx H-506

Contaminants, Residues Service laboratories



- Extraction as part of sample preparation prior to analysis of contaminants and residues in environmental or food samples

Chemicals and Pharma R&D



- Material design
- Research of active compounds in medicinal plants
- Characterization of polymers

Chemicals Quality control



- Quality control of materials and chemicals

-
- High analyte recoveries and low standard deviations thanks to exhaustive extractions
 - Determination of low contamination levels
 - Prevention of analyte deterioration from heat or oxygen

- Maximized flexibility for solvent and method selection
- Adapt to the changing requirements of your extraction tasks
- Running different extraction methods in parallel for fast method development

- Tailor-made performance for maximized sample throughput
- Easy operation with intuitive navigation
- Fully compliant with standard methods

UniversalExtractor E-800



BÜCHI



Quick and Compliant

Fast fat extraction without breaking the rules



True Soxhlet

- Soxhlet extraction is both exhaustive and robust. It is also the method most widely used to meet regulations for many sample matrices.
- Analytical risks or time-consuming validation of other extraction methods deviating from the standard do not exist.
- Used as a reference method for NIR calibrations.



Soxhlet extraction made faster

- Use of high-end components, such as the optical sensor, the powerful heating element, and optimized glass assembly, further reduce cycle times.
- An automated Soxhlet process produces results much faster than traditional glassware assemblies.
- Faster results and an unprecedented sample throughput per day.

Interchange between glass assemblies (SOX-HE-ECE)

- Easily change glass assemblies to comply with Soxhlet, Randall (HE) and Twisselmann (ECE)
- Not limited to one extraction method, but adaptable to your needs or changing demands
- Profit from unrivalled extraction times and the lowest solvent consumption with HE



HE

ECE

SOX

Interchangeable glass assembly

By simply changing the glass assembly, the FatExtractor E-500 complies with standard methods such as Soxhlet, Hot Extraction (HE) or Twisselmann (ECE).

Re-use your solvent

The freshly distilled solvent is collected in an easily accessible and detachable bottle. Execute an environmentally friendly extraction process and save money. The innovative flange z-seal system guarantees minimal solvent emission.



Individual level sensors

Achieve the highest turnaround of Soxhlet cycles by adjusting the level detection sensor to the sample volume. This significantly increases the extraction efficiency and your sample throughput per day.

Adapt to sample size

The main glass parts are expanded up to 60 %, as is required for the direct extraction of low fat samples.

FatExtractor E-500

Technical Data

Specification

Dimension (W × D × H)	638 × 595 × 613 mm
Net weight	42 kg
Power consumption	1300 W
Connection voltage	100 – 240 V (+/- 10 % VAC)
Frequency	50 / 60 Hz
Solvent recovery	> 90 %
Water consumption	max. 1.7 L / min

Application specific configurations



**FatExtractor
E-500 SOX / LSV**

**FatExtractor
E-500 HE**

**FatExtractor
E-500 ECE**

	FatExtractor E-500 SOX / LSV	FatExtractor E-500 HE	FatExtractor E-500 ECE
Method and synonyms	Soxhlet extraction	Hot extraction = Randall = Submersion	Economic Continous Extraction = Twisselmann
Method characteristics	High analytical safety and a very gentle process at low sample temperature	Corresponds to the extraction method of third party suppliers	Convenience is important
Reproducibility (RSD)	+++	+	++
Compliance	+++	++	+
Costs	+	+++	++
Glass assembly LSV* for higher sample quantities	Option	–	–
Analyte protection sensor detects the presence of beaker and solvent including solvent level	Option	Option	Option
Pro color display, 7" with touch screen	Option	Option	Option

* Large Sample Volume



Complementary and Robust Acid hydrolysis – a safe and smooth process



Compliant acid hydrolysis for total fat determination

- Acid hydrolysis prior to extraction is an essential work step of the total fat determination whereby matrix structures enclosing the fat fraction of food and feed samples are broken up
- Assures conformity with official regulations for the declaration of total fat content
- The standardized and exhaustive procedure guarantees reproducible results
- Supports large sample volumes of up to 10 gram samples for accurate results, independent of fat content or homogeneity



Safe handling

- Effective and long-lasting FKM sealings avoid exposure to harmful fumes
- Convenient transfer of the hydrolyzate without getting in contact with the sample



Easy-to-use

- The lift device supports smooth movement of the sample rack
- Efficient rinsing with dedicated rinsing caps
- Fast and convenient filtration for complete sample transfer and high recoveries
- Convenient transfer of the hydrolyzate into the Soxhlet extraction chamber with reusable glass sample tubes

Integrated workflow

The perfect match between hydrolysis and fat extraction. The specialized glass samples tube fits perfectly into the FatExtractor E-500.

Rinsing funnels

The innovative rinsing funnels facilitate the rinsing of hydrolysis vessels, and guarantee the quantitative transfer from the vessels into the glass sample tubes for easy handling and reproducible results.



Smooth filtration

Smooth filtration and rinsing of six samples in parallel is made possible thanks to a powerful vacuum source, optimized glass parts, as well as individual stop cocks that can interrupt the vacuum at each position.

Made for large sample volumes

The hydrolysis vessels can handle large sample volumes, both liquids and solids, of up to 10 g. A large sample volume ensures reproducible results for low-fat or particularly inhomogeneous samples.

Specialized hydrolysis vessels

Unique hydrolysis vessels reduce foaming even with large sample volumes.

HydroEx H-506

Technical Data

Specification

Dimension (W × D × H)	312 x 614 x 470 mm
Net weight	13 kg
Power consumption	1200 W
Connection voltage	220 – 240 V or 110 – 120 V (+/- 10 % VAC)
Frequency	50 / 60 Hz

Process of acid hydrolysis

1. Sample preparation



2. Hydrolysis



3. Filtration and rinsing



4. Drying and transfer to FatExtractor E-500





Powerful and Perfect for Multitasking

High performance with widest application range



Multitasking

- Six distinct extraction positions enable individual process control and simultaneous operation of different extraction methods
- Different extraction tasks can be carried out in parallel
- Faster method development and higher sample throughput



Analyte protection sensor

- Patent pending analyte protection ensures that a minimum level of solvent remains in the beaker, resulting in an enhanced analyte recovery
- Prevents the deterioration and degradation of heat sensitive analytes during all process steps
- Ensures that the concentration step in the extraction procedure is safe and reproducible.



Fully inert conditions and maximized safety for the analyte

- All components in the UniversalExtractor E-800 that are in contact with the sample and the solvents are made of inert material
- Eliminates sample contamination and any memory effects from leaching materials
- The inert gas supply is selectable through-out all stages of the process
- Inert gas is automatically switched on if the analyte protection sensor is triggered

Flexible applications

- Profit from five different extraction methods in one universal glass assembly. Choose the optimal extraction method to achieve the highest analyte recovery with the lowest variation of results
- For low analyte concentration, the Large Sample Volume (LSV) glass assembly can increase the sample volume by 60 %
- Fast and equal heating, even for high boiling solvents such as water or toluene

Optimal sample size

The LSV glass assembly with the larger extraction chamber and beaker allows for the higher sample quantities needed to achieve the required detection limit of the analyte. The main glass parts are enlarged by 60 %.

High performance condensers

The large condenser captures vapors efficiently and ensures the highest solvent recovery (> 90 %), even with volatile solvents. Vapor emissions are eliminated allowing for operation outside of the fume hood.



Full visibility

The entire extraction process is visible. The glass assemblies can easily be accessed and disassembled for cleaning and for decontamination in the oven (+ 450 °C).

Analyte protection sensor

Monitors the solvent level in the beaker and prevents the beakers from running dry. For a safer process and the best protection of heat-sensitive analytes.

UniversalExtractor E-800

Technical Data

Specification

Dimension (W × D × H)	638 × 595 × 613 mm
Net weight	45 kg
Power consumption	1780 W
Connection voltage	200 – 240 V (+/- 10 %)
Frequency	50 / 60 Hz
Solvent recovery	> 90 %
Water consumption	max. 1.7 L / min

Application specific configurations



	UniversalExtractor E-800 ECE	UniversalExtractor E-800 Standard / LSV	UniversalExtractor E-800 Pro / LSV
Soxhlet	–	●	●
Soxhlet warm	–	–	●
Hot extraction	–	–	●
Continuous flow	–	●	●
Twisselmann	●	–	●
Universal glass assembly incl. level sensor and valve	–	●	●
ECE glass assembly	●	–	–
Analyte protection sensor	●	●	●
Pro color display, 7" with touch screen	●	●	●
Chamber heater	–	–	●
Universal glass chamber, LSV	–	Option	Option
Inert gas supply	–	–	Option

Product overview

The best solution for your needs

Hydrolysis

Fat extraction



**HydroEx
H-506**

**FatExtractor
E-500 SOX / LSV**

Analyte

Fat and lipids	●	●
Food contaminants and residues	–	–
POP, TPH, PPCP, VOC and explosives	–	–
Polymer constituents or contaminants	–	–
Active compounds in medicinal plants	–	–

Characteristics

Method	Acid hydrolysis	Classical Soxhlet
Typical process time [min]	~ 35	~ 90
Max. working solvent volume [mL]	100	175
Sample holder volume [mL]	65	65 / 120 (glass sample tube)
Thimble size: inner diameter by length [ID × L, mm]		25 × 100; 33 × 94 / 33 × 94; 43 × 118
Typical solvent use per sample [mL]	100	100
Solvents	HCl solution	Chloroform, hexane, petroleum-/diethyl ether
Temperature range [°C], boiling points	< 110	< 70
Materials in contact with sample	Borosilicate glass 3.3 FKM	Borosilicate glass 3.3, FKM, FFKM

Fat extraction

Universal extraction



FatExtractor E-500 HE	FatExtractor E-500 ECE	UniversalExtractor E-800 ECE	UniversalExtractor E-800 Standard / LSV	UniversalExtractor E-800 Pro / LSV
●	●	●	●	●
-	-	-	●	●
-	-	-	-	●
-	-	●	●	●
-	-	-	-	●
Hot extraction = Randall = Submersion	Economic Continous Extraction = Twisselmann	Economic Continous Extraction = Twisselmann	Soxhlet, Continuous Flow	Soxhlet, Soxhlet Warm, Hot Extraction, Continous Flow, Twisselmann
~ 40	~ 60	> 120	> 120	> 120
100	175	175	175 / 320	175 / 320
65 (glass sample tube)	65 (glass sample tube)	65 / 120	130 / 220	130 / 220
25 x 100; 33 x 94	25 x 100; 33 x 94	25 x 100; 33 x 94	25 x 150; 33 x 150 / 33 x 150; 43 x 150	25 x 150; 33 x 150 / 33 x 150; 43 x 150
50	70	70	110 / 180	110 / 180
Chloroform, hexane, petroleum-/diethyl ether	Chloroform, hexane, petroleum-/diethyl ether	Water, organic solvents	Water, organic solvents	Water, organic solvents
< 70	< 70	< 150	< 150	< 150
Borosilicate glass 3.3, FKM	Borosilicate glass 3.3, FKM	Borosilicate glass 3.3, PTFE	Borosilicate glass 3.3, PTFE, FFKM	Borosilicate glass 3.3, PTFE, FFKM

Fully compliant solutions

Meeting standards and regulations

Fat Determination with FatExtractor E-500

Application	SOX	HE	ECE
Feed	ISO 6492 98/64/EC	ISO 6492/11085 98/64/EC AOAC 2003.06	ISO 6492 98/64/EC
Chocolate	AOAC 963.15 AOAC 920.75 ISO 23275-1		LFGB §64
Dairy	ISO 3890-1		LFGB §64
Bakery, cereal, nut	AOAC 945.16 AOAC 948.22	ISO 11085 AOAC 2003.05	LFGB §64
Meat	ISO 1443	AOAC 991.36 ISO 1444	LFGB §64

Total Fat Extraction with FatExtractor E-500 and HydroIEx H-506

	SOX	Explanation
Feed	ISO 6492/11085-B 98/64/EC	Feed containing products of animal origin incl. milk, or of vegetable origin from which fats cannot be extracted without prior hydrolysis.
Dairy (Weibull-Berntrop)	ISO 8262-1	
Cereals and cereals-based products	ISO 11085- B	For materials from which the oils and fats cannot be completely extracted without prior hydrolysis
Meat	ISO 1443	

Universal extractions with UniversalExtractor E-800

Application	SOX	HE	ECE
Dioxins, PCBS in feeding stuff	EN 16215		
PAHs in ambient air	ISO 12884		
PCBs in waste in soils	DIN EN 15308/16167		
Semivolatiles in solids	EPA 3540C	EPA 3541	
PBDEs in sludge and sediments	ISO 22032		
Extractables in polymers and rubber	DIN EN ISO 6427 ISO 1407		DIN EN ISO 6427 ISO 1407

Improved remote control possibilities

Easy monitoring and reporting

The Extraction Reports App provides push messages, real-time status of the extraction progress and comprehensive reporting.



Remote monitoring

Push notifications and real-time status delivered on your mobile device help to minimize operators presence in front of the instrument. Immediate intervention reduces down-time and maximizes the productivity of the instrument.

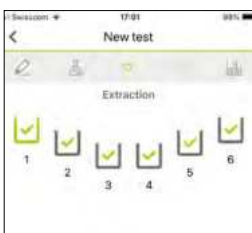

Full traceability

The app reports the extraction parameters and process steps for complete documentation. Furthermore, it implements the calculation of gravimetric results based on the sample weight and data.

Configurator

Put together your extraction system with the BUCHI configurator according to your specific needs. Simply choose from the various options available and receive your order code including a picture of your specific configuration.

More information about our configurator can be found at:

www.buchi.com/configurator

Accessories



Conversion kits

Enables the exchange of extraction methods by simply switching the glass assemblies (SOX, HE, ECE).



Holder and support

Beneficial holder and support for weighing purposes facilitates the easy handling of the beakers and vessels.



Recirculating chillers F-305 / F-308 / F-314

For efficient, economic and ecological cooling. Enables sustainable operation due to zero water consumption.



Vacuum pump set

Ensures an efficient and constant vacuum for acid hydrolysis (filtration step). Replaces the water jet pump for sustainable operation due to no water consumption.

Consumables



Sand

Use high quality sand for the best results. The sand is annealed and has the correct particle size for use in hydrolysis and extraction.



Celite®

Diatomaceous earth binds the fat during hydrolysis and its quality has an impact on results. BUCHI evaluated Celite 545 and recommends using this type for the highest fat recovery.



Extraction thimbles

The BUCHI extraction thimbles offer the best quality and optimized dimensions for the sample extraction. Choose a suitable thimble size depending on your sample quantity and glass assembly.

Consumable costs per sample

Consumable costs [CHF]	Total fat determination ¹	Fat extraction ²	Extraction ³
Sand (40 g), Celite® (4 g)	2.10	–	–
Thimble ⁴	–	5.30	5.30
Solvent petrol ether (100 mL)	1.85	1.85	–
Solvent n-hexane (120 mL)	–	–	5.30
Total costs [CHF]	3.95	7.15	10.60

¹ FatExtractor E-500 SOX and HydroEx H-506, ² FatExtractor E-500 SOX, ³ UniversalExtractor E-800 Pro,

⁴ Alternatively use glass sample tubes with frit, price per piece

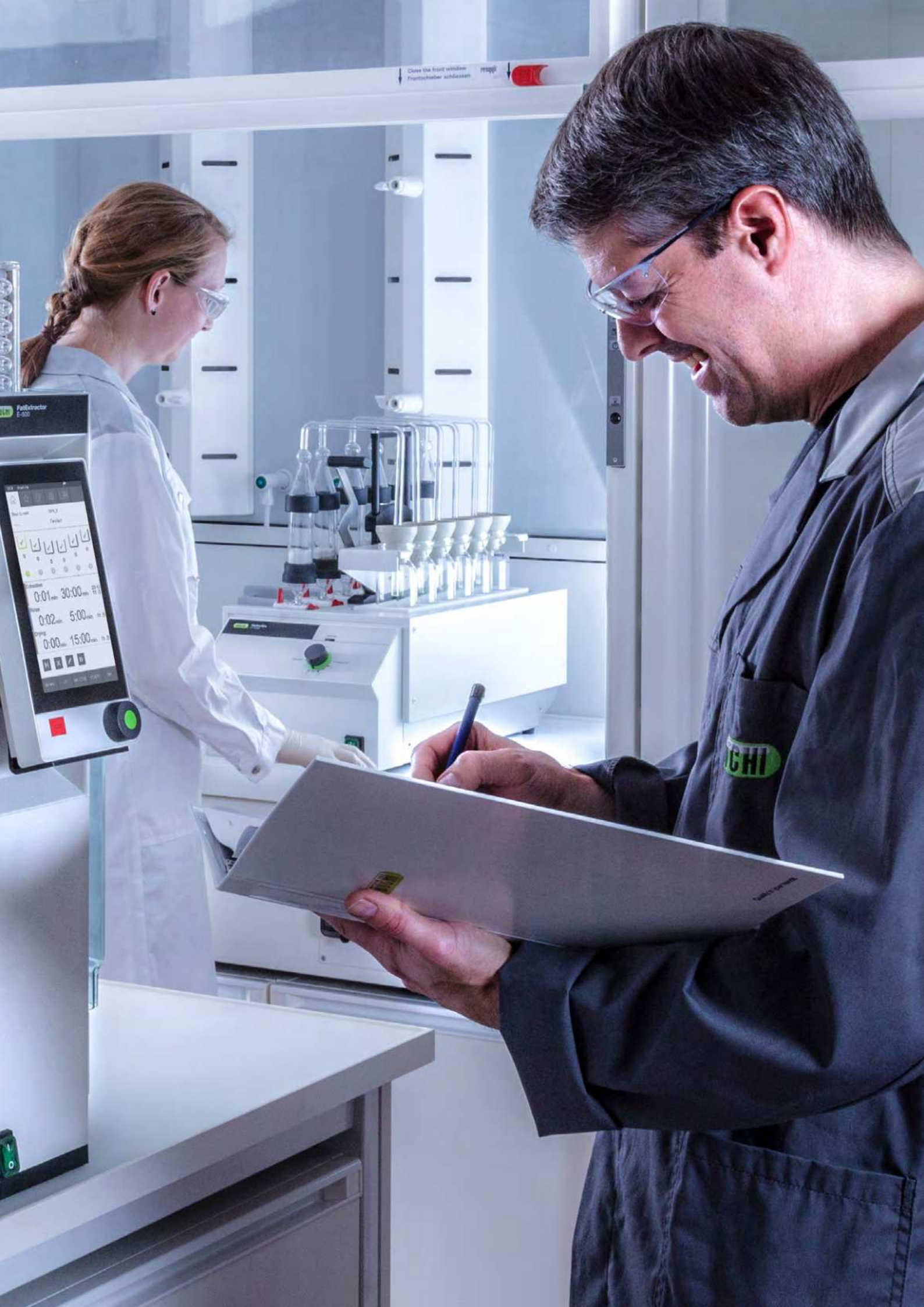

Service & Training

BUCHI Service packages

BUCHI START – The highest efficiency from the very beginning

From a professional installation to a carefree agreement that will leave you with full cost predictability and the highest possible system efficiency. www.buchi.com/start

«Install»

- Product installation and testing
- Hands-on training from a certified technician
- Evaluation of the immediate surroundings of your new product
- Best integration of your new product into the existing infrastructure

«IQ/OQ»

- Product or system installation
- Installation and Operational Qualification

BUCHI EXACT – Certified accuracy for highest level of confidence

Receive comprehensive qualifications with all of your BUCHI products. We perform qualification services on a level that can only be achieved by the manufacturer. www.buchi.com/exact

«OQ»

- Our one-time OQ service will provide you with all the necessary documents and certificates.
- The service team will remind you about the option for a follow-up OQ before the certificates expire.

«OQ Circle»

Buying an OQ package will grant you an additional discount on the documents and offer you priority service with automated visit scheduling.

BUCHI CARE – Unbeatable Reliability

Maintaining a heavily used device requires different parts and inspection frequencies than units that are operated occasionally. Our approach takes factors like these into consideration to provide you with an optimal yet cost-efficient solution. www.buchi.com/care

BUCHI ACADEMY – Increase your know-how, get the edge over your competition

Expert know-how is provided by the application chemists in our competence centers in Flawil, Beijing and Mumbai and the locally available experts at our market organizations.

Our scientific support offers pre-sales feasibility studies, tailored solution offers, after sales onsite support, regular basic to advanced courses and on demand customized training.

www.buchi.com/academy

Complete your portfolio

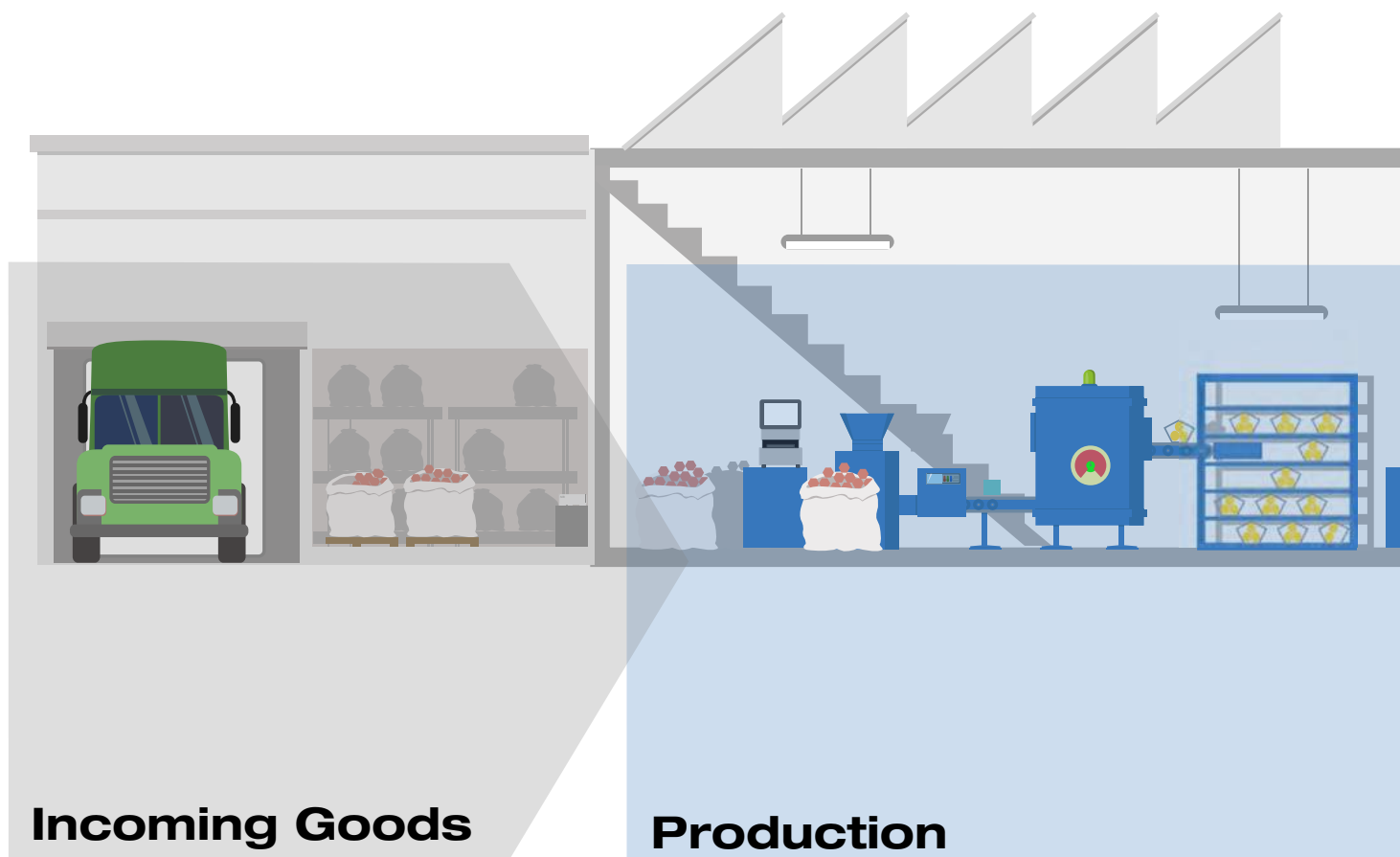

Incoming Goods

Production



NIR-Online

Closely monitoring key parameters such as moisture, fat or protein is crucial in correcting deviations that may occur during any manufacturing process. BUCHI NIR-Online® analyzers continuously provide accurate measurements within seconds to guarantee maximum production efficiency.



NIR

During production, it is important to be able to control quality efficiently and quickly at each step of the process, from raw materials to finished products. The BUCHI NIR Solutions are easy to use by any operator and provide reliable results even in harsh production environments.

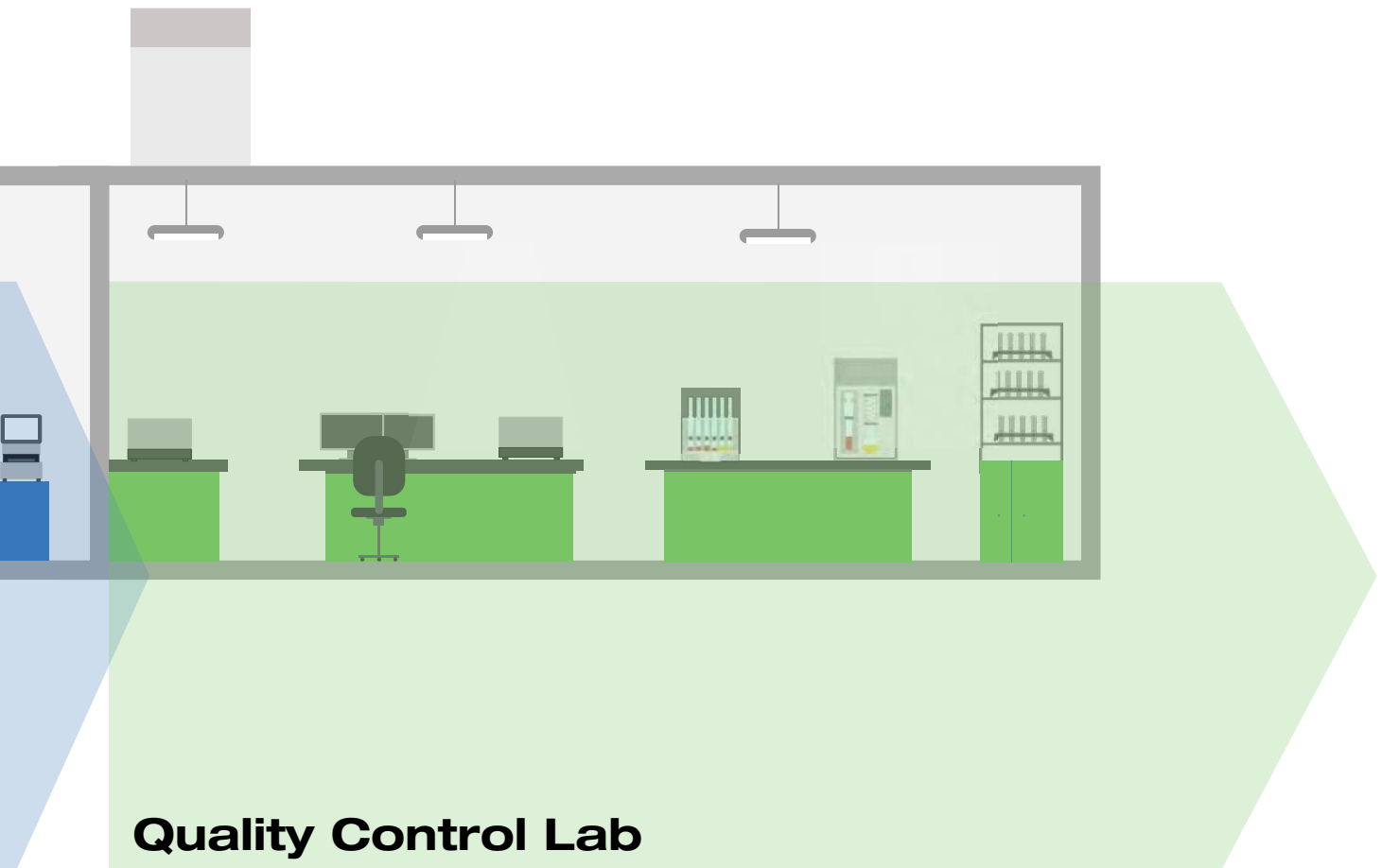

Quality Control Lab



Kjeldahl

In the most demanding of quality control environments, for high throughput, the KjelMaster K-375 automates the measurement of nitrogen and protein. First-in-class in usability, automation, user administration and advanced data management. For both potentiometric and colorimetric titration methods.



Extraction

Extraction is not only sample preparation, it is a crucial step for an accurate and reliable result. Whether it is to simply measure fat, or the most demanding residue and contaminants in different matrices, our solutions cover the whole range of automated extraction methods; from Soxhlet, to hot extraction and pressurized solvent extraction.

Core messages to our customers

BUCHI creates added value

«Quality in your hands» is the guiding principle that shapes our philosophy and our actions. It challenges us to provide outstanding services that are precisely tailored to your needs. This means that we must stay in close contact with our customers. That is why we keep in touch and continue to work very hard to understand you and your business even better.

We help you by providing high-quality products, systems, solutions, applications and services that offer you added value. This allows you to focus entirely on your processes and your work.



Competent

We have the technological expertise and decades of experience needed to provide competent support and work with you to continually improve our services.



Reliable

We guarantee the quality and functionality of our equipment and will continue to help you quickly and efficiently whenever something does not operate to your satisfaction.



Safe

By collaborating closely with you, we do everything in our power to make our products, systems, solutions, applications and services as safe as possible for people and the environment.



Cost-effective

We strive to create a high level of economic benefit and maximum added value for you.



Global

As an international family-owned business with own subsidiaries and qualified distributors, we have a presence wherever you are located.



Easy

We support you by providing carefully designed solutions as well as instruments and systems that are easy to operate.



Sustainable

We support environmentally friendly processes and manufacture products that have a long service life. We utilize advanced technologies to leave the smallest environmental footprint possible.

BÜCHI Labortechnik AG
CH – 9230 Flawil
T +41 71 394 63 63
F +41 71 394 64 64
info@buchi.com

www.buchi.com

Quality in your hands





HydroEx H-506

Technical data sheet

The HydroEx H-506 ensures convenient and safe acid hydrolysis for total fat content determination handling six samples simultaneously. The method complies with the standardized methods (Weibull Stoldt, AOAC).

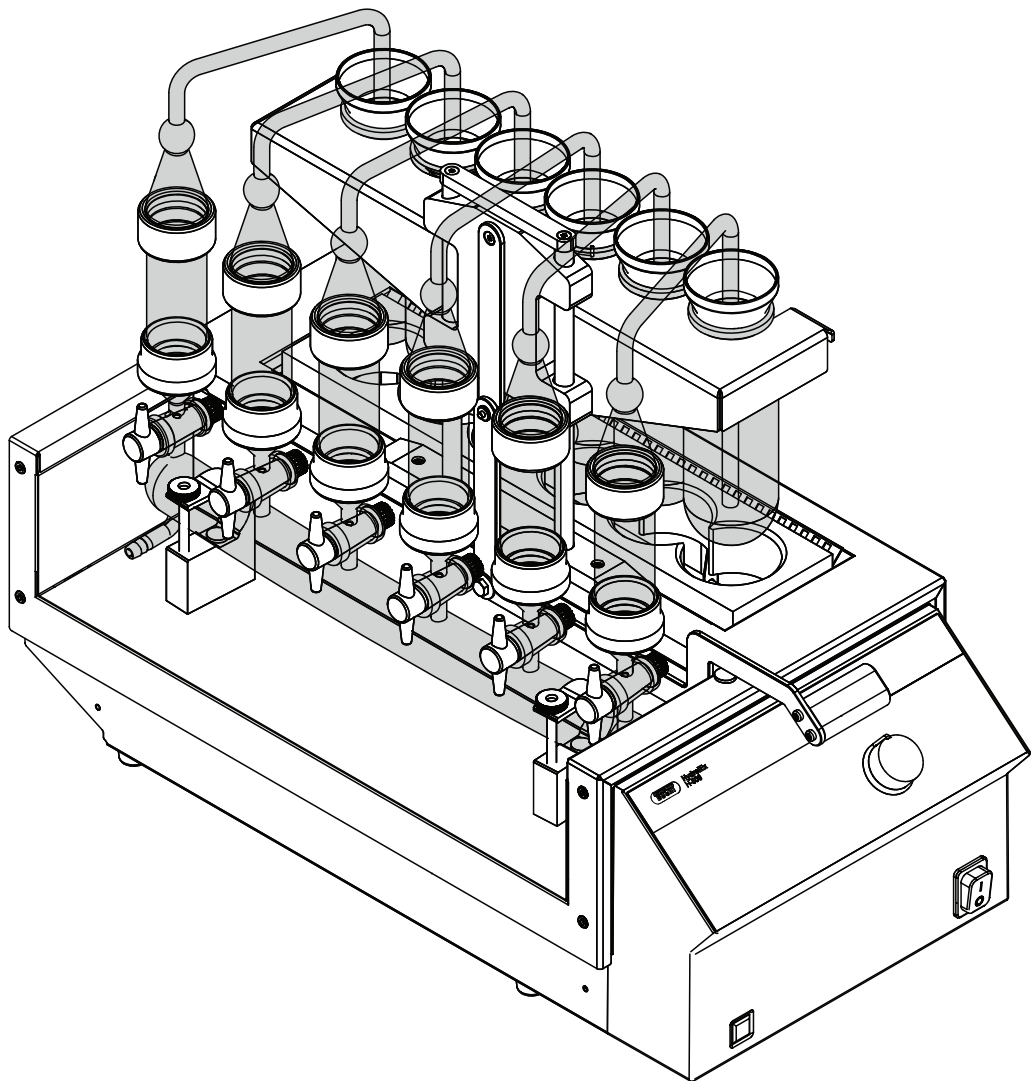

Order Code

Choose the configuration according to your needs:

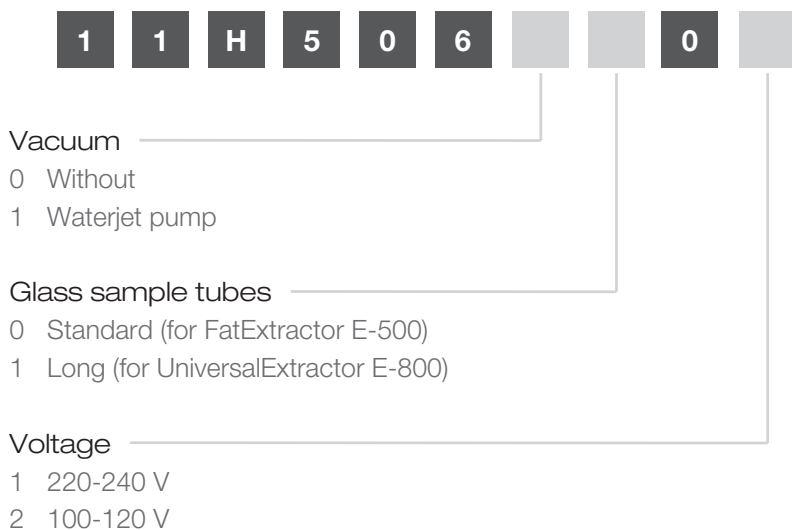

Scope of delivery

All configurations are supplied ready to use.

	HydrolEx H-506 for FatExtractor E-500	HydrolEx H-506 for UniversalExtractor E-800
HydrolEx H-506	1	1
Upper rubber couplings	6	6
Lower rubber couplings bottom	6	6
Glass sample tube with frit	6	-
Glass sample tube with frit, long	-	6
Rinsing funnel	6	6
Sample aspiration tube	6	-
Sample aspiration tube, long	-	6
Suction tube cpl.	1	1
Hydrolysis vessel	6	6
Vacuum hose 2 m	1	1
Quartz sand 2.5 kg	1	1
Power cable	1	1
Operation Manual	1	1

HydroEx H-506

Specification	HydroEx H-506 for 115 V	HydroEx H-506 for 230 V
Dimensions (W x D x H)	312 x 614 x 470	312 x 614 x 470
Weight (without glassware)	13 kg	13 kg
Weight (with glassware)	16.5 kg	16.5 kg
Connection voltage	110 - 120 ± 10 % VAC	220 - 240 ± 10 % VAC
Fuse	10 A	10 A
Frequency	50 / 60 Hz	50 / 60 Hz
Overvoltage category	II	II
Protection class	1	1
Pollution degree	2	2
Power consumption	1200 W	1200 W
Temperature range heater	70 - 495 °C	70 - 495 °C
Total Heating power	1200 W	1200 W
Number of hydrolysis positions	6	6
Approvals	CE / CSA	CE / CSA

Ambient conditions

For indoor use only.

Max. altitude above sea level	2000 m
Ambient temperature	5–40 °C
Maximum relative humidity	80% for temperatures up to 31 °C decreasing linearly to 50 % relative humidity at 40 °C
Storage temperature	max. 45 °C

Spare parts

	Order no.	Image
Insulation plate	11065169	
Suction tube, cpl.	11064546	
Set of hydrolysis vessels, 2 pcs.	11064547	
Set of aspiration tubes, 2 pcs.	11064548	
Set of aspiration tubes, long, 2 pcs.	11069475	
Glass sample tubes with frit, 6 pcs.	11067497	
Glass sample tubes with frit, long, 6 pcs. The glass sample tubes with 150 mm length fit perfectly into the Universal glass extraction chamber.	11067815	
Set of rinsing funnels, 2pcs.	11067582	
Vacuum hose, 2 m	040459	

	Order no.	Image
Set of upper couplings, FKM, 3 pcs.	11068611	
Set of lower couplings, FKM, 3 pcs.	11068612	

Accessories

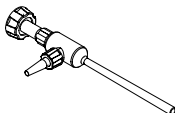
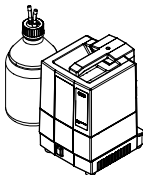
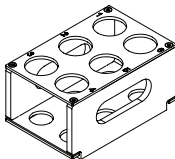
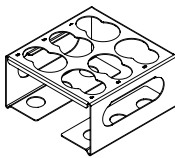
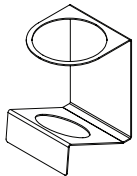
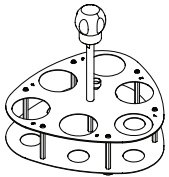
	Order no.	Image
Water jet pump. Plastic Used when tap water is used to generate vacuum.	002913	
Suction set with pump Vacuum pump V-100, bottle, tubing	11068473	
Holder for glass sample tubes, PTFE	11067220	
Holder for glass sample tubes, stainless steel	11067219	
Weighing support for hydrolysis vessels	11067040	
Hydrolysis vessel carrier	11067492	

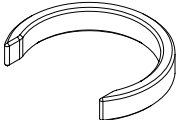
	Order no.	Image
<p>Adapter clips for B-411 sample tubes, 4 pcs.</p> <p>These adapters allow the use of glass sample tubes for B-411/ B-811 on combination with the HydrolEx H-506. In addition the rubber couplings of the E-416 / B-411 are needed for the use in the H-506. EPDM (037381) or Viton (044491)</p>	11069239	

Consumables

	Order no.
Quartz sand 0.3 - 0.9 mm, 2.5 kg	037689
Celite® 545, 1 kg	11068920
Quartz sand (25 kg)	034925