

Growth chambers



KBW| KBWF series



Growth chambers

Series KBW	Page 6
------------	--------

Series KBWF	Page 9
-------------	--------

Options and Accessories	Page 12
-------------------------	---------

Homogeneous light in combination with a constant temperature and humidity is necessary to achieve ideal growth in plants or other organisms. A BINDER humidity chamber offers all this. This is how KBW Series growth chambers create ideal conditions for the culture using light and temperature. The KBF series also offers a system for humidity regulation. The APT.line™ preheating chamber from BINDER, in connection with fast-reacting humidity regulation, highly effective cooling and uniform light distribution, ensures natural growth conditions.

PRODUCT SELECTION GROWTH CHAMBERS

Features	KBW › Page 6	KBWF › Page 9
Model		
Model 240	•	•
Model 400	•	–
Model 720	•	•
General data		
Temperature range without illumination cassettes [°C]		0...70
Temperature range with 100% illumination [°C]	5...60	10...60
Humidity range [% RH]	–	10...80
Ethernet interface	•	•
Forced convection	•	•
Controller and timer functions		
Controller display		TFT touch
Ramp function	•	•
Time delayed OFF	•	•
Time delayed ON	•	•
Temperature dependent delayed OFF	•	•
Programming option	•	•
Weekly program function	•	•
Adjustable fan speed	•	•
Real-time clock	•	•
Class 3.1 independent temperature safety device	•	•
Temperature alarm, acoustic	•	•
Temperature alarm, visual	•	•
•Standard equipment		

ADVANTAGES AT A GLANCE



HOMOGENEOUS TEMPERATURE DISTRIBUTION

Series KBW, KBWF

BINDER APT.line™ preheating chamber technology ensures long-term operational stability even under full load.



FAST AND PRECISE HUMIDIFICATION

Series KBWF

The patented long-life steam humidification system and the capacitive humidity sensor ensure on target humidity values.



NATURE-EMULATING GROWTH CONDITIONS

Series KBW

Using illumination cassettes provides flexible placement options which ensures homogeneous light distribution over the entire usable area. The light qualities are individually selectable.



INTUITIVE TOUCHSCREEN CONTROLLER

Series KBW, KBWF

State-of-the-art controller technology with time-segment and real-time programming with internal data recording

Series KBW | with light

The BINDER climate chamber with illumination of the KBW series achieves homogeneous light distribution with its natural illumination. That allows this growth chamber to create constant lighting and temperature conditions.



KBW 400 model

MAIN FEATURES

- Temperature range: 0 °C to 70 °C
- Temperature range with light: 5 °C to 60 °C
- positionable illumination cassettes, each with 5 fluorescent tubes
- APT.line™ preheating chamber technology
- Adjustable fan speed
- Stainless steel racks
- Access port with silicone plug, 30 mm, left
- Class 3.1 independent temperature safety device (DIN 12880) with visual and audible temperature alarm
- Computer interface: Ethernet
- Intuitive touchscreen controller with time-segment and real-time programming with internal data recording

AVAILABLE SIZES

Model	Interior volume [L]	Online data sheets
KBW 240	247	go2binder.com/en-KBW240
KBW 400	400	go2binder.com/en-KBW400
KBW 720	698	go2binder.com/en-KBW720

i TIPS & TRICKS

Benefit from our many years of experience, as demonstrated in our technical papers:

Tips & Tricks: go2binder.com/en-tips-tricks

Case Studies: go2binder.com/en-case-studies

TECHNICAL DATA

Description	KBW 240	KBW 400	KBW 720
Housing dimensions not incl. fittings and connections			
Width net [mm]	925	925	1250
Height net [mm]	1465	1950	1925
Depth net [mm]	800	805	890
Internal Dimensions			
Width [mm]	650	650	970
Height [mm]	785	1270	1250
Depth [mm]	485	485	576
Measures			
Interior volume [L]	247	400	698
Net weight of the unit (empty) [kg]	195	252	377
permitted load [kg]	100	120	150
Load per rack [kg]	30	30	45
Performance Data Temperature			
Temperature range with 100% illumination [°C]	5...60	5...60	5...60
Temperature range without illumination cassettes [°C]	0...70	0...70	0...70
Temperature variation with 100% illumination [± K]	0.5	1.5	1.0
Temperature variation without illumination cassettes [± K]	0.5	0.5	0.5
Temperature fluctuation with 100% illumination [± K]	0.2	0.2	0.1
Temperature fluctuation without illumination cassettes [± K]	0.1	0.1	0.1
Lightdata per Illumination Cassettes			
Daylight tubes [W/m ²]	24	24	38
Daylight tubes [lx]	9000	9000	13000
Fluora® growth lamps [W/m ²]	23	23	36
Fluora® growth lamps [lx]	7500	7500	10500
Arabidopsis lamps [W/m ²]	32	32	43
Arabidopsis lamps [lx]	11000	11000	14000
Electrical data			
Nominal power (version 230 V) [kW]	1.4	1.6	2.7
Fixtures			
Number of shelves (std./max.)	2/7	3/12	3/12
Number of illumination cassettes (std./max.)	2/2	3/3	3/3

ORDERING INFORMATION [Art. No.]

Further details: Go to www.binder-world.com > Search > Enter Article Number

Voltage	Option model	KBW 240	KBW 400	KBW 720
200...240 V 1 50 Hz	Standard	9020-0338	9020-0339	9020-0340

► You will find a selection of options, accessories and services suitable for each product on page 12

LIGHT SPECTRA

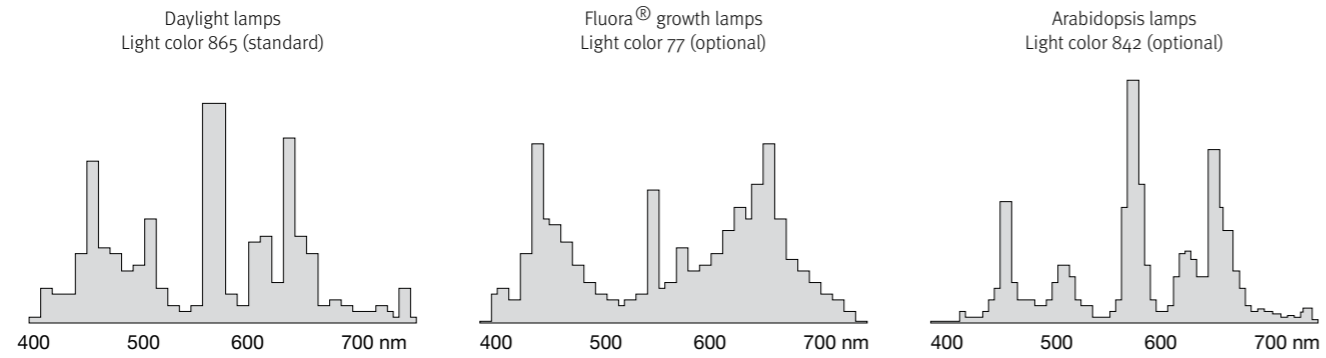

DIMENSIONS incl. fittings and connections [mm]

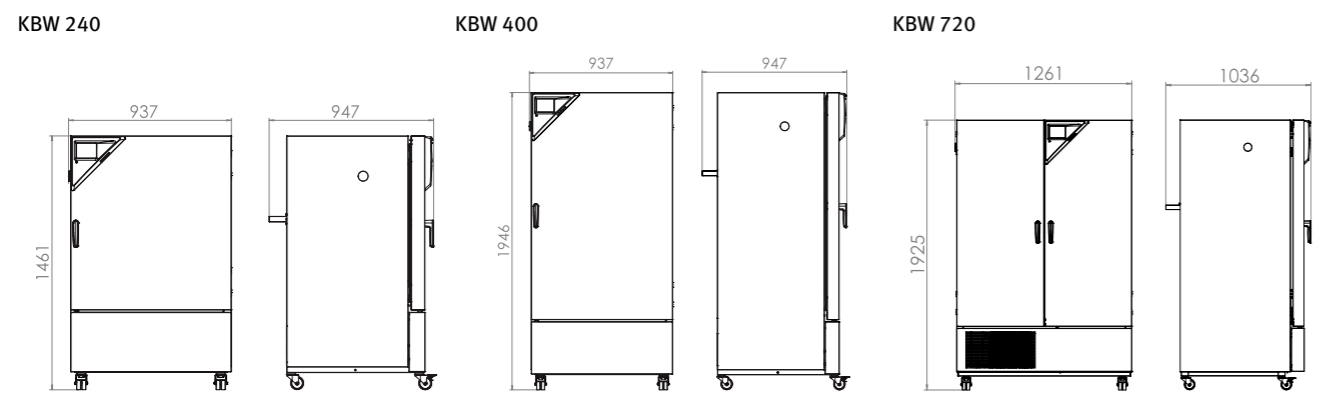

Series KBWF | with light and humidity

The BINDER climate chamber with illumination of the KBW series achieves homogeneous light distribution with its natural illumination. That allows this climate chamber to create constant lighting and temperature conditions.



KBWF 240 model

MAIN FEATURES

- Temperature range: 0 °C to 70 °C
- Temperature range with light: 10 °C to 60 °C
- Humidity range: 10 % to 80 % RH
- positionable illumination cassettes, each with 5 fluorescent tubes
- APT.line™ preheating chamber technology
- Adjustable fan speed
- Humidity regulation with capacitive humidity sensor and vapor humidification
- Display via color LCD monitor
- Tightly-sealed inner door made of tempered safety glass
- Intuitive touchscreen controller with time-segment and real-time programming with internal data recording
- Tight-sealing inner door made of safety glass (ESG) with specialTIMELESS coating

AVAILABLE SIZES

Model	Interior volume [L]	Online data sheets
KBWF 240	247	go2binder.com/en-KBWF240
KBWF 720	700	go2binder.com/en-KBWF720

Find all details online
go2binder.com/en-KBWF

TECHNICAL DATA

Description	KBWF 240	KBWF 720
Housing dimensions not incl. fittings and connections		
Width net [mm]	925	1250
Height net [mm]	1465	1925
Depth net [mm]	800	890
Internal Dimensions		
Width [mm]	650	973
Height [mm]	785	1250
Depth [mm]	485	576
Measures		
Interior volume [L]	247	700
Net weight of the unit (empty) [kg]	214	374
permitted load [kg]	100	150
Load per rack [kg]	30	45
Performance Data Temperature		
Temperature range with 100% illumination [°C]	10...60	10...60
Temperature range without illumination cassettes [°C]	0...70	0...70
Performance Data Climate		
Temperature range with 100% illumination [°C]	10...60	20...60
Temperature range without illumination cassettes [°C]	10...70	10...70
Humidity range with illumination cassettes, with illumination [% RH]	10...75	10...75
Humidity range without illumination [% RH]	10...80	10...80
Lightdata per Illumination Cassettes		
Daylight tubes [W/m ²]	24	38
Daylight tubes [lx]	9000	13000
Fluora® growth lamps [W/m ²]	23	36
Fluora® growth lamps [lx]	7500	10500
Arabidopsis lamps [W/m ²]	32	43
Arabidopsis lamps [lx]	11000	14000
Electrical data		
Nominal power (version 230 V) [kW]	2.4	3.5
Fixtures		
Number of shelves (std./max.)	2/7	3/12
Number of illumination cassettes (std./max.)	2/2	3/3

ORDERING INFORMATION [Art. No.]

Further details: Go to www.binder-world.com > Search > Enter Article Number

Voltage	Option model	KBWF 240	KBWF 720
200...240 V 1 50 Hz	Standard	9020-0336	9020-0337

► You will find a selection of options, accessories and services suitable for each product on page 12

LIGHT SPECTRA

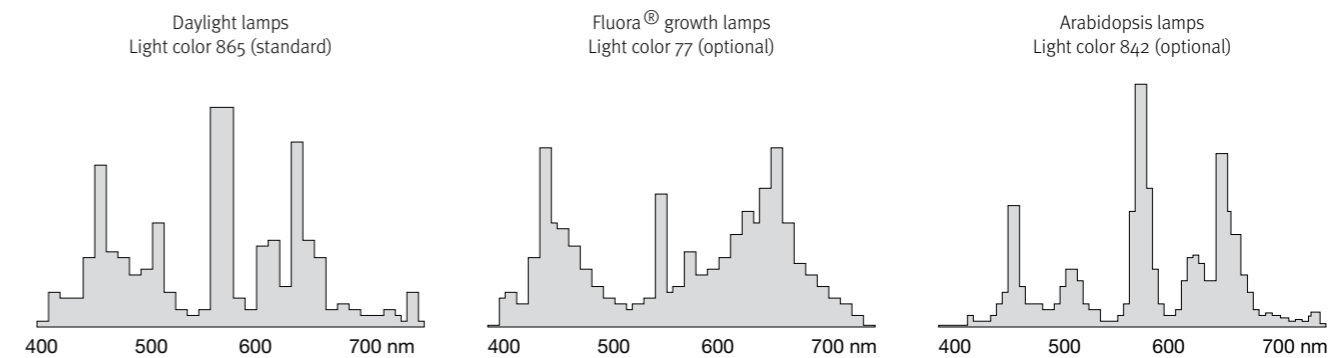

DIMENSIONS incl. fittings and connections [mm]

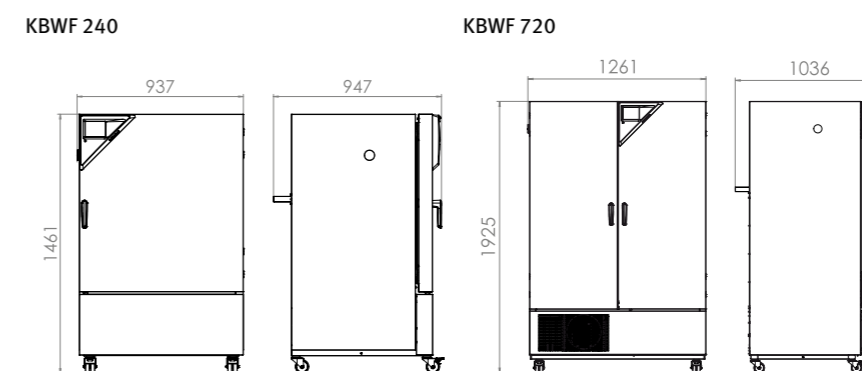

EXCERPT FROM OPTIONS AND ACCESSORIES

Access port with silicone plug	For introducing external measuring instruments. Large selection of different diameters and positions (left, right, or top) Series KBW, KBWF
Data Logger Kit TH	Independent temperature and humidity data logging. The tailored product solution contains helpful accessories: From the magnetic mounting of the data logger to the BINDER unit and securing sensor cable for accurate readings. Series KBW, KBWF
Interior socket	Waterproof, switched flush-mounting box (CA3GD) for nominal voltage in unit interior, with cover and corresponding plug (nominal voltage; max. 500 W; max. 90 °C; protection class IP67) Series KBW, KBWF
Illumination	Illumination cassettes equipped with FLUORA®, Arabidopsis, or daylight fluorescent tubes. Series KBW, KBWF
Services	You can access our installation, maintenance, calibration, validation, or warranty services by taking out a Maintenance Service Agreement or by simply getting in touch when you need us. More information is available in the accessories and services chapter. Series KBW, KBWF
BINDER INDIVIDUAL	Using a BINDER series production product as a basis, we develop individual solutions as a single unit or in small batches. All products are tested, certified, and supplied with a full functional guarantee and warranty. More information is available in the accessories and services chapter. Series KBW, KBWF

► All extras online go2binder.com/en-options



Access port with silicone plug



Data Logger



Shaker operation in the chamber



Illumination variants

BINDER products

CO₂ incubators

Incubators

Cooling incubators

Growth chambers

Ultralow temperature freezers

Drying and heating chambers

Safety drying chambers

Vacuum drying chambers

Constant climate chambers

Dynamic climate chambers



Never miss a product novelty -
Subscribe and keep up to speed with
the BINDER monthly newsletter.

Subscription

go2binder.com/en-newsletter-subscription



Best conditions for your success

BINDER GmbH

Tuttlingen, Germany

Tel +49 7462 2005 0
Fax +49 7462 2005 100
info@binder-world.com
www.binder-world.com

BINDER Asia Pacific (Hong Kong) Ltd.

Kowloon, Hong Kong, P.R. China

Tel +852 39070500
Fax +852 39070507
asia@binder-world.com
www.binder-world.com

BINDER Environmental Testing Equipment (Shanghai) Co., Ltd. Shanghai, P.R.China

Tel +86 21 685 808 25
Fax +86 21 685 808 29
china@binder-world.com
www.binder-world.com

Representative Office for CIS

Moscow, Russia

Tel +7 495 988 15 16
Fax +7 495 988 15 17
russia@binder-world.com
www.binder-world.ru

BINDER Inc.

Bohemia, NY, USA

Tel +1 631 224 4340
Fax +1 631 224 4354
usa@binder-world.com
www.binder-world.us