



## High-Speed Emulsifier/Dispenser

# HOMOGENIZING MIXER MARK II

## Model 2.5(3L)

Half a century has passed since the Homogenizing Mixer, the best-selling high-speed emulsifier/disperser, was developed and introduced.

Despite the ever-changing world around it, the Homogenizing Mixer has been used in a variety of industrial fields such as chemicals, pharmaceuticals, cosmetics, and foods. The mixer has earned its well-established and long-standing reputation by achievements in areas such as new product development and product quality improvement.

### Features

- The mixing head can be removed easily for cleaning.
- The mixing head uses rotor/stator construction for high-speed mixing, emulsification, and dispersion.
- The brushless motor used does not generate dust, reduces noise, and stabilizes rotation speed at low speeds.

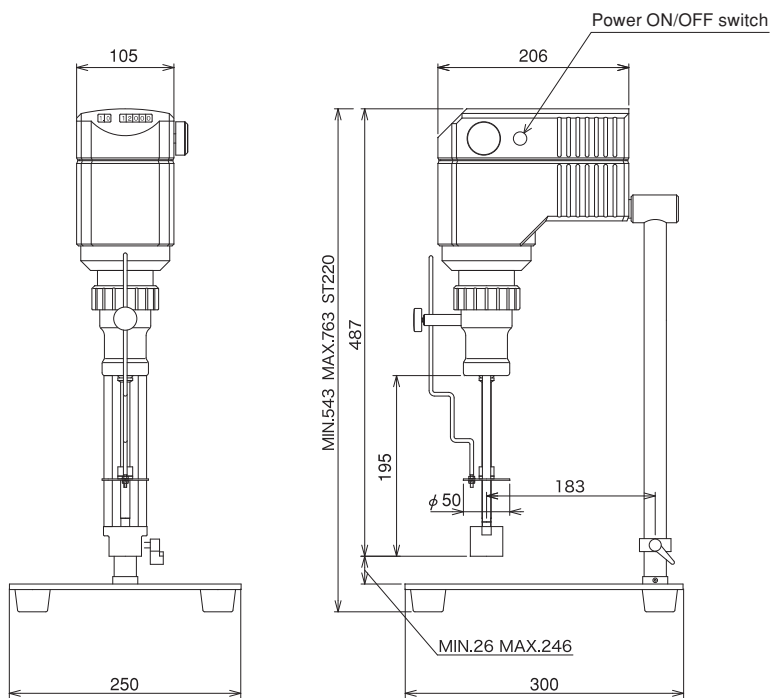

### ◆ Standard Specifications

Model 2.5 <sup>*1</sup>	
Power Supply	AC 100V 50/60Hz 1 phase Cable length: 1.5m Plug: Grounded 2P plug (3-prong → 2-prong adapter included)
Motor	0.25kW Speed: 500-12,000r/min
Materials	Wetted parts: SUS304 Sleeve bearing <sup>*2</sup> : CAC502A
Control Panel	Instruments: ammeter, tachometer Operation: RPM dial
Capacity	3L (recommended vessel: $\phi$ 145mm $\times$ 225mm)
Approx. Weight	12kg

<sup>\*1</sup>The mixing heads of the Homogenizing Mixer Mark II Model 2.5 and Homogenizing Disper Model 2.5 are not interchangeable.

<sup>\*2</sup>Also available in PTFE and SUS304.