

# General Specifications

## Model RAGL Laboratory suitable Glass ROTAMETER

GS 01R01B08-00E-E

Rotameter RAGL is designed for the measurement of clean liquids and gases.

The conical glass metering tube has a free rotating float. The Rotameter is mounted in a vertical pipeline with flow direction upwards. The flow is indicated by the top of the float and can be read from a scale on the measuring tube or from an attached scale.

The glass tube of the RAGL is exchangeable without removing the meter from its installation.

Long glass tubes allow good reading for more resolution and accurate measurement.

### FEATURES

- Large selection of measuring ranges
- High repeatability by a free rotating float even at low flow rates
- Low pressure loss
- Visual check of the medium
- Non-powered local indication
- Large selection of scales
- Optional built-in regulation valve
- Optional limit switches
- Easy and fast glass tube replacement possible

### Typical Applications

- Transparent liquids
- Low viscous liquids
- Gases

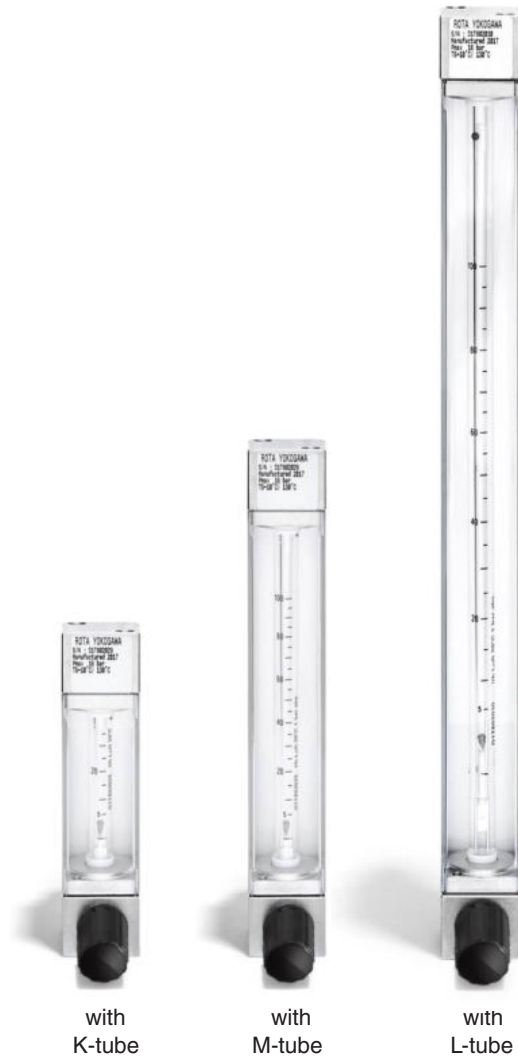

### Contents

Features	page 1
Standard Specifications	page 2
Model Specifications	page 6
Options	page 7
Dimensions and weights	page 8

## STANDARD SPECIFICATIONS

### RoHS Directive 2011/65/EU:

RoHS conform according to EN 50581

### Measurable flow rates:

- Water, 20 °C (68 °F): 0.002 l/h to 110 l/h  
(0.0005 gph to 29 gph)
- Air, 20 °C (68 °F); 1 bar abs.:  
0.2 l/h to 3500 l/h  
(0.05 gph to 922 gph)

The measurable flow rates are depending from density and viscosity of the fluid. To find the fluid specific measuring range please use the Yokogawa FlowConfigurator: [www.FlowConfigurator.com](http://www.FlowConfigurator.com).

### Measuring range:

- K-, M-tube: ≈10:1
- L-tube: ≈20:1

### Measuring tubes:

K6xx; M6xx; L6xx; K7xx; M7xx; L7xx  
K, M, L: length code  
6, 7: diameter code  
xx: cone code

**Table 1: Measuring accuracy**

Glass metering tube	Length	Measuring accuracy acc. VDI/VDE 3513 sheet 2 (q <sub>G</sub> =50 %)	Measuring accuracy acc. VDI/VDE 3513 sheet 2 (q <sub>G</sub> =100 %)
K631 - K743	75 mm	4 % (for ball 6 %)	-----
M613 - M622	150 mm	-----	4 %
M624 - M747	150 mm	2.5 %	-----
L613 - L623	300 mm	-----	2.5%
L624 - L747	300 mm	1.6 %	-----

For detailed accuracy calculation please use the Yokogawa FlowConfigurator: [www.FlowConfigurator.com](http://www.FlowConfigurator.com).

The accuracy is given under calibration conditions. For liquid service it has to be taken into account, that the indication is viscosity dependent and the accuracy can only be kept if the temperature is constant.

### Calibration conditions:

Air, 18 °C to 25 °C (64.4 °F to 77 °F)  
atmospheric pressure

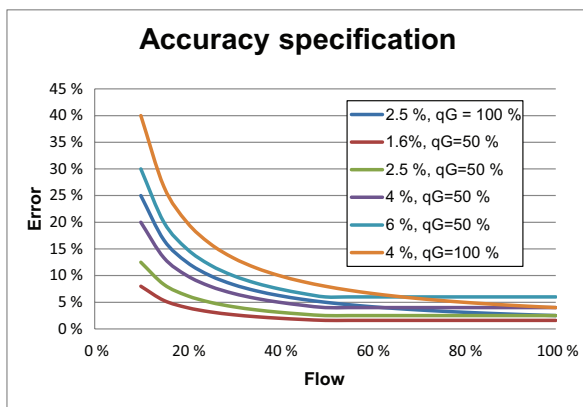

**Fig. 1 Accuracy specification overview**

### Process and ambient temperature:

- Head material stainless steel(SS): -20 °C to 130 °C  
(-4 °F to 266 °F)
- Head material polypropylene(PP): 0 °C to 80 °C  
(32 °F to 176 °F)
- Scale G, N, D, F: max. 100 °C (212 °F)
- Scale with option /IB: max. 130 °C (266 °F)
- With option /GR□: 0 °C to 65 °C  
(32 °F to 149 °F)
- With option /NBR: -20 °C to 100 °C  
(-4 °F to 212 °F)
- With option /R1 or /R3: -20 °C to 80 °C  
(-4 °F to 176 °F)

### Material wetted parts:

SS is 316L (1.4404), 316 Ti (1.4571) or 1.4408

#### • Process connection:

- female thread: PP; SS

The threads are directly machined in the head.

- Cutting ring: SS
- Nozzle for hose connection: SS
- Swagelok® connection: SS

#### • Heads:

PP; SS

#### • O-rings in case of valves:

- standard: FPM (Viton)
- option /NBR: NBR (Perbunan)
- option /Kal: FFKM (Kalrez)

#### • Glass:

Borosilicate 3.1

#### • Floats:

SS, titan, glass ball, mu-metal, PVDF, aluminum oxide, SS ball, PVDF

#### • Valve:

SS spindle, PTFE spindle seal, silver seat

Valves are plug -in valves

#### • Float stopper:

- standard: PTFE
- option /S1: SS

#### • Protection cover:

Polycarbonate

#### • Valve knob:

Polyamide

### Tube sealing:

PTFE

### Installation length:

- with K-tubes: 100 mm (3.94")
- with M-tubes: 175 mm (6.9")
- with L-tubes: 325 mm (12.8")

### Pressure loss:

2 mbar to 18 mbar at the float  
(0.029 psi to 0.261 psi)

The pressure loss at the float is given by the FlowConfigurator: [www.FlowConfigurator.com](http://www.FlowConfigurator.com).

Valves will create additional pressure loss.

### Weight:

see table 4

### Attached scale:

Made from hard plastic material with milled letters black in white, for high visibility.

Limit switches are not possible with attached scale.

### Marking:

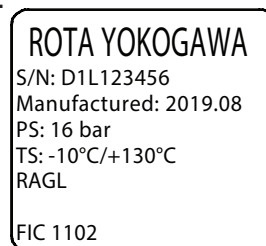

**Fig. 2: Example of name plate**

**APPROVALS IN EAEU AND CIS COUNTRIES**  
**Eurasian Conformity (EAC)**

RAGL with options /GR□ complies to applicable Technical Regulations valid in EAEU countries Russia, Belarus, Kazakhstan, Armenia and Kyrgyzstan.

- TR CU 004
- TR CU 020

**Pattern Approval certificate of Measuring Instruments**

RAGL has “Pattern Approval Certificate of Measuring Instruments” and is registered as a measuring instrument in Russia.

Option /QR: Primary verification approval with technical passport

For export to other CIS countries please contact your Yokogawa representative.

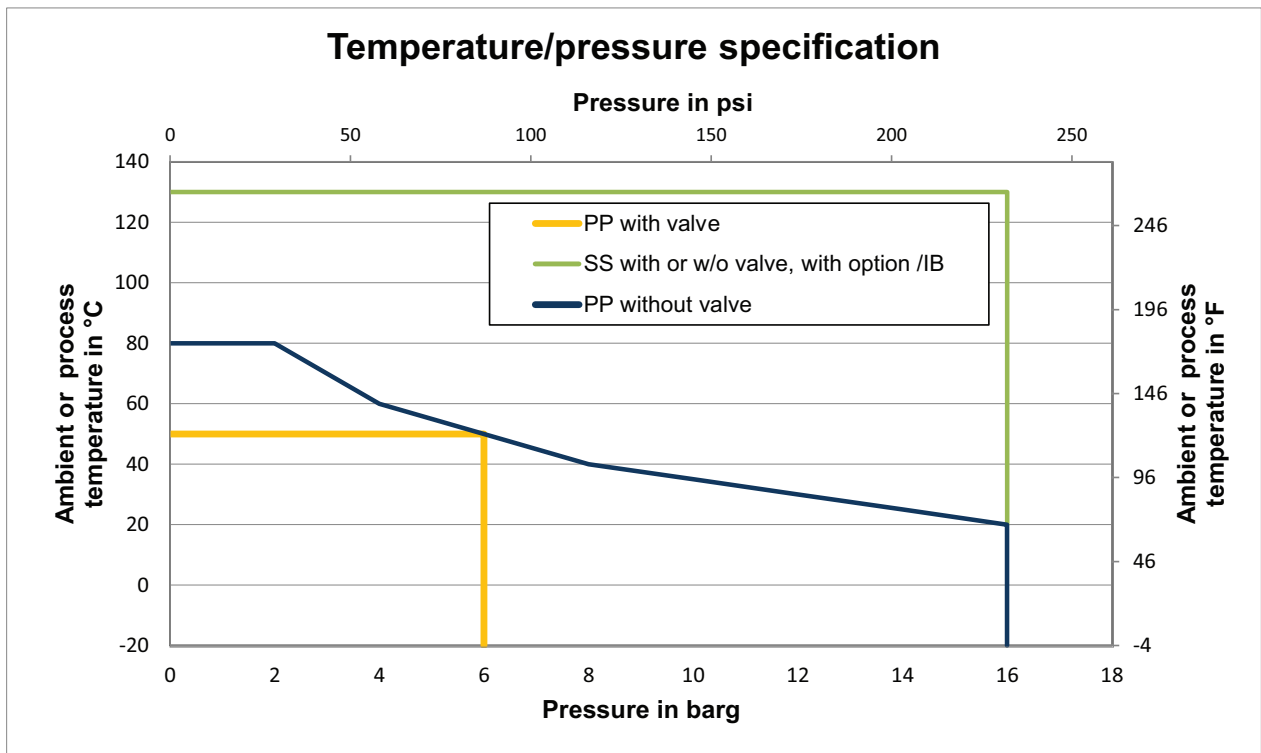

**Fig.3: Temperature/pressure specification**

Further temperature restrictions are applicable in case of option /NBR, /R1 and /R3.

**Table 2:  $Kv_s$  and  $Cv_s$  value of the valves**

Cone	13 to 21	22 to 41	42 to 47	52 to 57
$Kv_s$	0.024 m <sup>3</sup> /h	0.06 m <sup>3</sup> /h	0.24 m <sup>3</sup> /h	1.125 m <sup>3</sup> /h
$Cv_s$	0.028 gpm	0.07 gpm	0.28 gpm	1.316 gpm

**LIMIT SWITCH**, option /GR1 to /GR8

With limit switches no protection cover for the tube is provided.

**Floats:**

- Mumetal (MU) or PVDF (PD)
- $Q_{min} > 0.004$  l/h water or 0.3 l/h air  
( $Q_{min} > 0.001$  gph water or 0.076 gph air)

**Type:**

Bistable inductive ring sensor to be used with the appropriate power supply

<b>Power supply:</b>	4.5 V to 15 V DC
<b>Current levels:</b>	acc. DIN EN 60947-5-6
<b>Temperature range:</b>	-20 °C to +65 °C (-4 °F to 149 °F)
<b>Protection:</b>	IP 67
<b>Electrical connection:</b>	2 x 0.14 mm <sup>2</sup> , with shield 0.4 mm <sup>2</sup> , 2 m (78") long

**EMC compliance:**

According to EN 60947-5-2 table 8 (for use in industrial locations). Based on EMC compliance the limit switch is marked with CE, EAC and RCM mark.

**Hazardous area use (option /KS1, /ES1):**

**Temperature range:** -20 °C to +60 °C  
(-4 °F to 140 °F)

**Certificate No.:**

- PTB 03 ATEX 2111 (/KS1)
- IECEx PTB13.0023 (/ES1)

**Protection:** Ex ia IIC T6 Gb

**Safety relevant input Parameter:**

$U_i = 12$  V,  $I_i = 22$  mA,  $P_i = 66$  mW,  
 $L_i = 20$  mH,  $C_i = 200$  nF

**CE-marking:**    II 2 G

**Markings on the label of the limit switch:**

CE, EAC, China RoHS, RCM, Morocco

**POWER SUPPLY FOR LIMIT SWITCHES**, option /W□A and /W□B**Type:**

Acc. to EN 60947-5-6

- KFA5-SR2-Ex\*-W (115 V AC); \* = 1 or 2
- KFA6-SR2-Ex\*-W (230 V AC); \* = 1 or 2
- KFD2-SR2-Ex\*-W (24 V DC); \* = 1 or 2

**Power supply:**

- 230 V AC  $\pm 10$  %, 45 to 65 Hz
- 115 V AC  $\pm 10$  %, 45 to 65 Hz
- 24 V DC  $\pm 25$  %

**Relay output:**

1 or 2 potential-free change over contact(s)

**Switching capacity:**

Max. 250 V AC, max. 2 A

**POWER SUPPLY FOR INTRINSICALLY SAFE LIMIT SWITCHES**, option /W□A and /W□B

Technical data same as above.

**Type:**

Acc. to EN 60947-5-6

- KFA5-SR2-Ex\*-W (115 V AC); \* = 1 or 2
- KFA6-SR2-Ex\*-W (230 V AC); \* = 1 or 2
- KFD2-SR2-Ex\*-W (24 V DC); \* = 1 or 2

**Approvals:**

- KFA5-SR2-Ex\*-W:
  - ATEX: PTB 00 ATEX 2081
  - FM: ID 3011578
  - IECEx: PTB11.0031
  - EAC: RU C-DE.EX01.B.00102/19
  - NEPSI: GYJ17.1283
- KFA6-SR2-Ex\*-W:
  - ATEX: PTB 00 ATEX 2081
  - FM: ID 3011578
  - IECEx: PTB11.0031
  - EAC: RU C-DE.EX01.B.00102/19
  - NEPSI: GYJ17.1283
- KFD2-SR2-Ex\*-W:
  - ATEX: PTB 00 ATEX 2080
  - FM: ID 3011578
  - IECEx: PTB11.0034
  - EAC: RU C-DE.EX01.B.00102/19
  - NEPSI: GYJ17.1284

**Control circuit (ATEX):**

[Ex ia] IIC; group II; category (1)GD

**Entity parameter:**

See certificates

**FLOW CONTROLLER, option /R1 and /R3**

Flow regulator for constant flow in case of variations in process pressure.

These are no valves to reduce the pressure.

- **Flow Controller /R1 for liquids and gases**

The regulator keeps the flow rate constant in case of a variable inlet pressure and constant back pressure. For gases the process conditions are the back conditions. The inlet pressure should be minimum 400 mbar larger than the back pressure (see Fig.3).

- **Flow Controller /R3 for gases with fluctuations of the back pressure and constant inlet pressure.**

The process conditions are the inlet conditions. The inlet pressure should be minimum 400 mbar larger than the back pressure.

**Max. liquid flow:** 100 l/h (26.4 gph)  
**Max. gas flow:** 3250 l/h (858.56 gph)  
**Max. pressure:** 25 bar (362.6 psi)  
**Temperature range:** -20 °C to +80 °C  
 (-4 °F to 176 °F)

**Table 3: Material of the controllers**

	Housing	Diaphragm	Springs
/R1 or /R3	SS	PTFE	SS

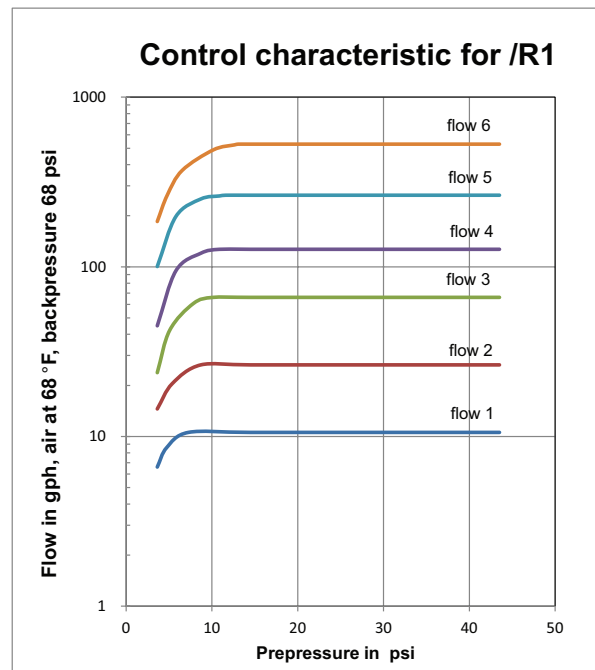
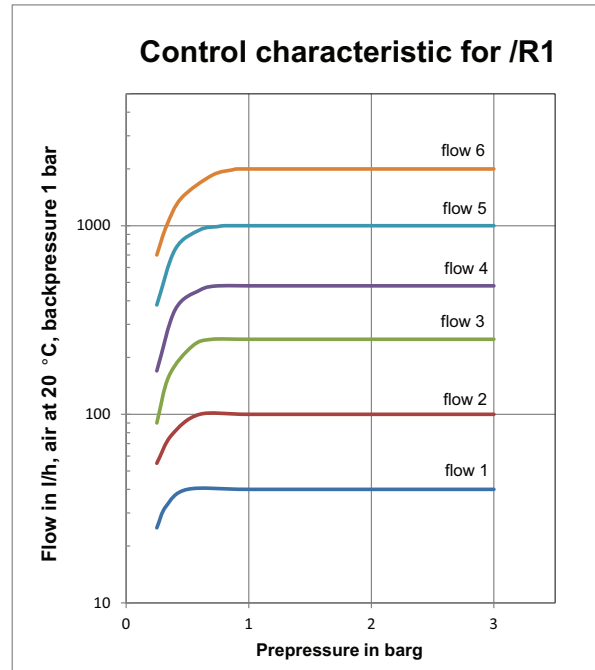

**Fig. 4 Control characteristic for /R1**

The above curves show the control characteristic of the inlet flow regulator /R1 with air for 6 different flowrates, each with fixed valve position, back pressure 1 bar (14.5 psi) (atmosphere conditions).

For the smallest flowrate the regulation works best from 0.4 bar (5.8 psi) to 3 bar (43.5 psi) (or more) inlet pressure change, for the largest flowrate from 0.9 bar (13 psi) to 3 bar (43.5 psi) (or more).

## MODEL SPECIFICATIONS

Model	Suffix code	Description	Restrictions
RAGL41		Model name	
Process connections	-T0 -R0	Female thread ¼" NPT Female thread ¼" Rp	
Material process connections and heads	PP-PP SS-SS	Polypropylene head Stainless steel head	
Valve	NNN SV1 SV2	Without valve Inlet valve, silver seat Outlet valve, silver seat	
Tube length	-K -M -L	75 mm (2.95") 150 mm (5.91") 300 mm (11.8")	
Tube diameter	6 7	10 mm (0.39") 17 mm (0.67")	*) *)
Tube cone combination	XX		*)
Fluid scale	G A N D F	Fluid specification sticker scale on tube, recommended Fluid specification attached scale, blank tube mm scale, sticker scale on tube Dual scale: G and A Dual scale: N and A	Tmax = 100 °C (212 °F) Not with /GR□ Tmax = 100 °C (212 °F) Not with /GR□, Tmax = 100 °C (212 °F) Not with /GR□, Tmax = 100 °C (212 °F)
Float material	-AL -GL -KR -MU -PD -SR -SS -TT	Float aluminum Ball glass, black Sintered float Al <sub>2</sub> O <sub>3</sub> , red Float mumetal Float PVDF, milky white Ball SS Float SS Float titan	*) For gases only *) *) *) *) For liquids only *) *) *)
Float diameter	A B C D	1.6 mm (0.06") 3.2 mm (0.13") 6.3 mm (0.25") 9.5 mm (0.37")	*) *) *) *)
Flow mark	L G	Liquid Gas	*) *)
Float insertion	N	Standard	

\*)To be determined with the FlowConfigurator

## OPTIONS

Options	Option code	Description	Restrictions	
Marking	/B1	Tag plate(SS) fastened with wire, plate: 12 x 40 mm; marking must be provided by the customer	max. 45 characters	
	/BG	Customer specific notes		
Process adapters as added part	/C01	Cutting ring in SS for 6 mm outer diameter tubes	Only for RAGL41-T0	
	/C02	Cutting ring in SS for 8 mm outer diameter tubes	Only for RAGL41-T0	
	/C03	Cutting ring in SS for 10 mm outer diameter tubes	Only for RAGL41-T0	
	/C04	Cutting ring in SS for 12 mm outer diameter tubes	Only for RAGL41-T0	
	/P01	Nozzle in SS, for flexible hoses inner diameter 6 mm	Only for RAGL41-R0	
	/P02	Nozzle in SS, for flexible hoses inner diameter 8 mm	Only for RAGL41-R0	
	/W01	Swagelok® in SS for 6 mm outer diameter tubes	Only for RAGL41-T0	
	/W02	Swagelok® in SS for 8 mm outer diameter tubes	Only for RAGL41-T0	
Limit switches	/W03	Swagelok® in SS for 10 mm outer diameter tubes	Only for RAGL41-T0	
	/W04	Swagelok® in SS for 12 mm outer diameter tubes	Only for RAGL41-T0	
	/GR1	Bistable inductive ring sensor	Only for float MU A□N	
	/GR2	Bistable inductive ring sensor	Only for float PD B□N or MU B□N	
	/GR3	Bistable inductive ring sensor	Only for float PD C□N	
	/GR4	Bistable inductive ring sensor	Only for float MU C□N, MU D□N, PD D□N	
	/GR5	2 bistable inductive ring sensors (2 x /GR1)	Only for float MU A□N, not for K-tube	
	/GR6	2 bistable inductive ring sensors (2 x /GR2)	Only for float PD B□N or MU B□N, not for K-tube	
Hazardous area app.	/GR7	2 bistable inductive ring sensors (2 x /GR3)	Only for float PD C□N, not for K-tube	
	/GR8	2 bistable inductive ring sensors (2 x /GR4)	Only for float MU C□N, MU D□N, PD D□N, not for K-tube	
	/KS1	ATEX intrinsically safe "ia"	Only for /GR1 to /GR8	
	/ES1	IECEx intrinsically safe "ia"	Only for /GR1 to /GR8	
	Scale	/IB	Scale imprinted on the tube and burned in	Not for scale A, T max = 130 °C (266 °F)
	Tests and certificates	/H1	Oil and fat free for wetted surface acc. to Yokogawa specification	Not with /R1, /R3
		/P2	Certificate of compliance with the order acc. to EN 10204: 2004-2.1	
		/P3	As /P2 + Test report acc. to EN 10204: 2004-2.2	
/PP		Pressure test report for measuring system		
/PT		Flow table for recalculation to other fluid	Only for N and F scale, fluid data must be provided	
O-Rings	/NBR	NBR O-rings for valve (if ordered)	Temperature range: -20 °C to 100 °C (-4 °F to 212 °F)	
	/KAL	Kalrez O-rings for valve (if ordered)		
Alternative float stop	/S1	Float spring stops made of SS 1.4571		
Accessories	/QP	Means for panel mounting		
	/QB	With tapped holes in the connecting heads for mounting		
	/QF	Foot stand		
	/QC	Colored caps for valve knob (red, blue, yellow, green)	Only with valve	
Controller	/R1	Flow regulator for alternating pre-pressure	Only with SS-head, only with inlet valve	
	/R3	Flow regulator for alternating back-pressure	Only with SS-head, only with outlet valve, only for gases	
Country specific delivery	/KC	KC-mark for Korea		
	/CN	China RoHS mark	Only with option /GR□	
	/VR	Pattern Approval for Russia		
Country specific application	/QR	Primary Verification for Russia	Only with /VR. Not for cones 13 to 27.	
Power supply	/W1A	KFA5-SR2-Ex1.W, 115 V AC, 1 channel	For /GR1 to GR4	
	/W1B	KFA5-SR2-Ex2.W, 115 V AC, 2 channels	For /GR5 to GR8	
	/W2A	KFA6-SR2-Ex1.W, 230 V AC, 1 channel	For /GR1 to GR4	
	/W2B	KFA6-SR2-Ex2.W, 230 V AC, 2 channels	For /GR5 to GR8	
	/W4A	KFD2-SR2-Ex1.W, 24 V DC, 1 channel	For /GR1 to GR4	
	/W4B	KFD2-SR2-Ex2.W, 24 V DC, 2 channels	For /GR5 to GR8	
Special order	/Z	Customer specific design, must be specified separately. If /Z is selected, several suffix of Model Code can be changed to Z.		

By use of the FlowConfigurator [www.FlowConfigurator.com](http://www.FlowConfigurator.com) restrictions are automatically taken into account.

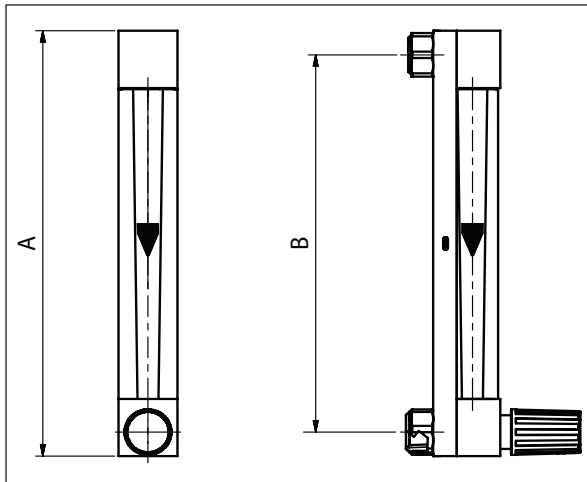
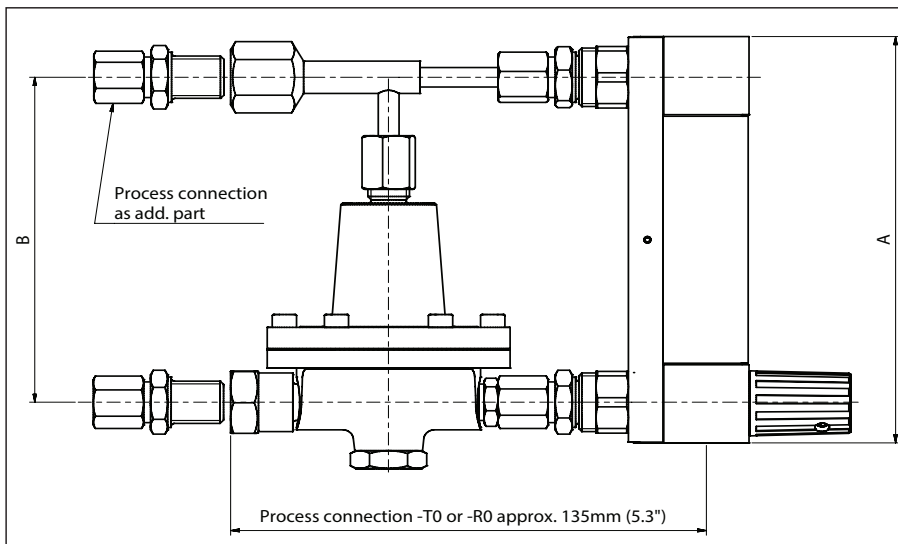
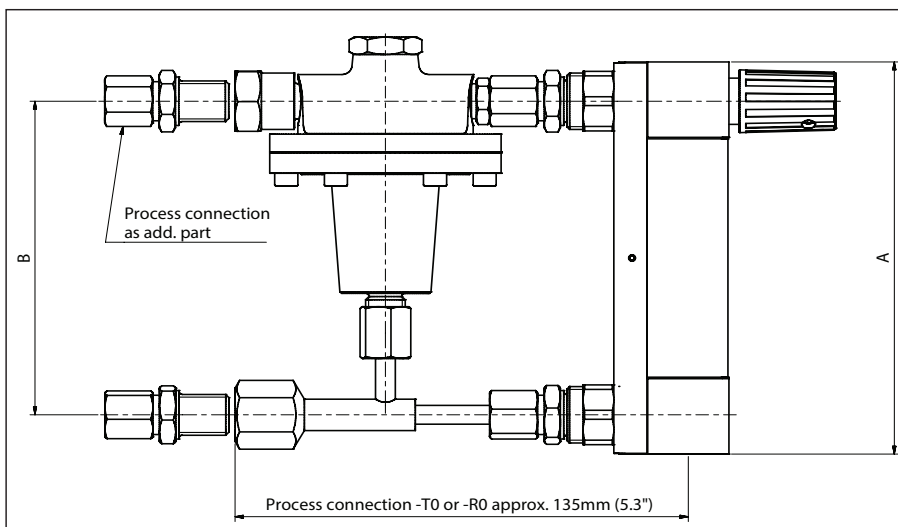
**DIMENSIONS AND WEIGHTS****Fig. 5 RAGL with valve****Fig. 6 Version with inlet valve and inlet flow controller option /R1****Fig. 7 Version with outlet valve and outlet flow controller option /R3**

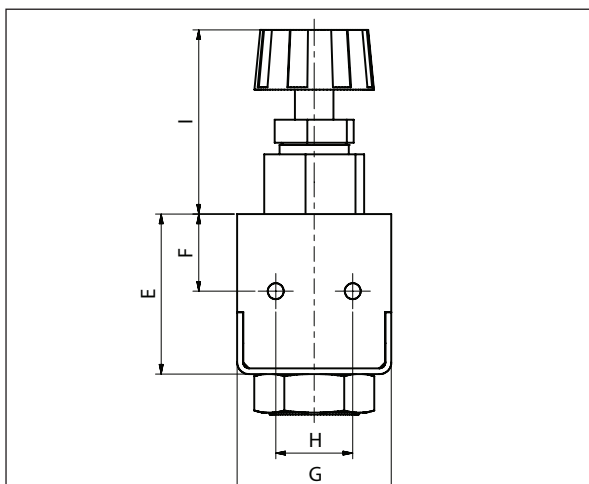

Fig. 8 Head dimensions (with or w/o valve) with tapped holes for option /QB

Table 4: Weights and dimensions

Model	Dimensions in mm (inch)		Weight in g (lbs)		
	A	B	w/o controller PP	w/o controller SS	with controller SS
RAGK41 with K6□□/K7□□	125 (4.92")	100 (3.93")	230 (0.51)	505 (1.11)	1225 (2.7)
RAGK41 with M6□□/M7□□	200 (7.87")	175 (6.89")	265 (0.58)	550 (1.21)	1270 (2.8)
RAGK41 with L6□□/L7□□	350 (13.78")	325 (12.8")	350 (0.77)	640 (1.41)	1360 (3.0)

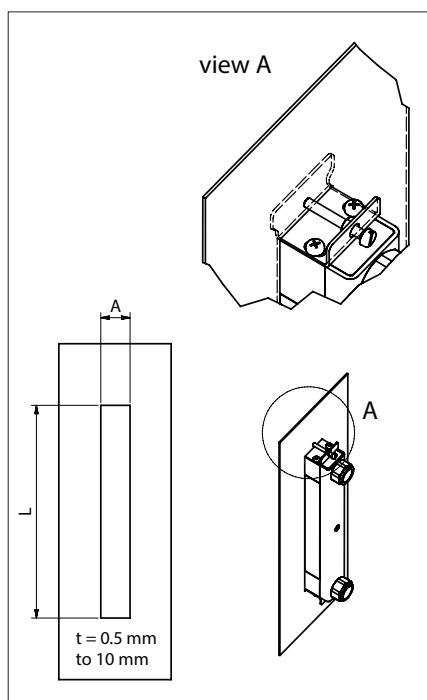

Table 6: Slot dimensions in the panel

Measuring tube	Dimensions in mm (inch)	
	A	L
K	31 (1.22)	128.3 (5.05)
M	31 (1.22)	203.3 (8)
L	31 (1.22)	353.3 (13.9)

Fig. 9 Head dimensions (with or w/o valve) with tapped holes for option /QB

Table 5: Dimensions of heads

Measuring tube	Dimensions in mm (inch)					Drill hole diameter in mm
	E	F	G	H	I	
all	33.3 (1.31")	16.8 (0.66")	30 (1.18")	20 (0.79")	33 (1.3")	3 (M3 screw)

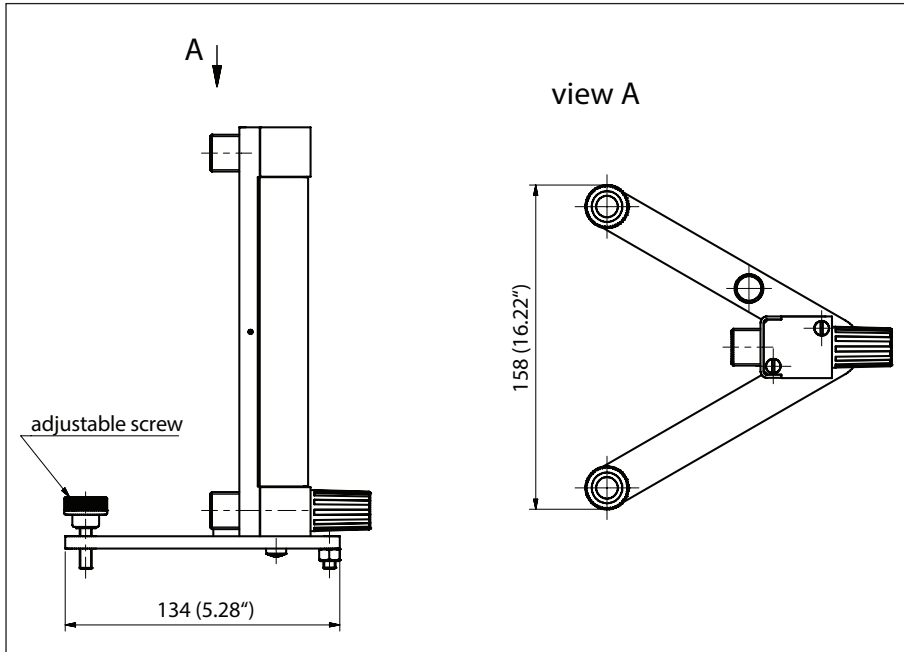

Fig. 10 Option /QF, foot stand, dimensions in mm (inch)

**REGISTERED TRADEMARKS**

Rotameter® is a trademark of Rota Yokogawa GmbH & Co. KG, a subsidiary of Yokogawa Electric Corporation, Japan. In the United Kingdom Rotameter™ is a trademark of Emerson Electric Co.

Swagelok®: Registered trademark of Swagelok Company, Solon, Ohio, USA

<p><b>YOKOGAWA ELECTRIC CORPORATION</b>  <b>Headquarters</b>                      2-9-32, Nakacho, Musashino-shi,                      Tokyo, 180-8750 JAPAN                      Phone : 81-422-52-5555  <b>Branch Sales Offices</b>                      Osaka, Nagoya, Hiroshima,                      Kurashiki, Fukuoka, Kitakyusyu</p>	<p><b>YOKOGAWA ELECTRIC CIS LTD.</b>                      Grokholskiy per 13 Building 2, 4th Floor 129090,                      Moscow, RUSSIA                      Phone : 7-495-737-7868                      Fax : 7-495-737-7869</p>	<p><b>YOKOGAWA INDIA LTD.</b>                      Plot No.96, Electronic City Complex,                      Hosur Road, Bangalore - 560 100,                      INDIA                      Phone : 91-80-4158-6000                      Fax : 91-80-2852-1442</p>
<p><b>YOKOGAWA CORPORATION OF AMERICA</b>  <b>Head Office</b>                      12530 West Airport Blvd, Sugar Land,                      Texas 77478, USA                      Phone : 1-281-340-3800                      Fax : 1-281-340-3838  <b>Georgia Office</b>                      2 Dart Road, Newnan, Georgia 30265, USA                      Phone : 1-800-888-6400/ 1-770-253-7000                      Fax : 1-770-254-0928</p>	<p><b>YOKOGAWA CHINA CO., LTD.</b>                      3F Tower D, No.568 West Tianshan RD,                      Shanghai CHINA, 200335                      Phone : 86-21-62396262                      Fax : 86-21-62387866</p>	<p><b>YOKOGAWA AUSTRALIA PTY. LTD.</b>                      Tower A, 112-118 Talavera Road,                      Macquarie Park NSW 2113,                      AUSTRALIA                      Phone : 61-2-8870-1100                      Fax : 61-2-8870-1111</p>
<p><b>YOKOGAWA AMERICA DO SUL LTDA.</b>                      Praca Acapulco, 31 - Santo Amaro, São Paulo/SP,                      BRAZIL, CEP-04675-190                      Phone : 55-11-5681-2400                      Fax : 55-11-5681-4434</p>	<p><b>YOKOGAWA ELECTRIC KOREA CO., LTD.</b>                      (Yokogawa B/D, Yangpyeong-dong 4-Ga),                      21, Seonyu-ro 45-gil, Yeongdeungpo-gu,                      Seoul, 150-866, KOREA                      Phone : 82-2-2628-6000                      Fax : 82-2-2628-6400</p>	<p><b>YOKOGAWA MIDDLE EAST &amp; AFRICA B.S.C.(C)</b>                      P.O. Box 10070, Manama, Building 577,                      Road 2516, Busaiteen 225, Muharraq,                      Kingdom of SAUDI ARABIA                      Phone : 973-17358100                      Fax : 973-17336100</p>
<p><b>YOKOGAWA EUROPE B. V.</b>                      Euroweg 2, 3825 HD Amersfoort,                      THE NETHERLANDS                      Phone : 31-88-4641000                      Fax : 31-88-4641111</p>	<p><b>YOKOGAWA ENGINEERING ASIA PTE. LTD.</b>                      5 Bedok South Road, Singapore 469270,                      SINGAPORE                      Phone : 65-6241-9933                      Fax : 65-6241-2606</p>	