

# General Specifications

## ROTAMETER RAMC Variable Area Flowmeter

### GS 01R01B02-00E-E

The short-tube Rotameter is used for measurement of flow rates of liquids and gases. Its special application is in turbulent, opaque or aggressive fluids. The instrument is mounted in a vertical pipeline with flow direction upwards. Inside the special shaped conical metal tube, a float is guided concentrically. The position of this float is magnetically transmitted to the indicator.

#### FEATURES

- Simple and low-cost installation, very robust and long-lasting device
- Energy efficient due to mechanical indication without power supply and very low pressure loss
- All common process connections available
- All wetted parts in stainless steel or PTFE
- Flow range water: 0.0025 to 130 m<sup>3</sup>/h (0.66 to 34342 gph)
- Flow range air: 0.075 to 1400 m<sup>3</sup>/h (2.65 to 49440 scfh) at 20 °C, 1 bar abs (68 °F, 14.5 psi)
- Measuring accuracy ±1.6 % acc. standard VDI/VDE 3513 sheet 2 (q<sub>G</sub> = 50 %)
- Float damping to avoid float bouncing with gas applications
- Optional heat tracing (with steam or fluid heat carrier)
- Indicator in stainless steel or aluminum, protection class IP66/67
- Microprocessor controlled transmitter with 24 V, 115 V or 230 V power supply
- Suitable for hazardous area applications
- FMEDA report available for SIL application
- Limit switches, also available as "fail-safe" version
- Electronic transmitter as standard with digital display with the following features:
  - ◆ Flow indication (totalizer, actual, percent)
  - ◆ Indication of different volume- and mass flow units
  - ◆ Possibility of user calibration in the field
  - ◆ Float blocking indication function
  - ◆ Adjustable signal output damping
  - ◆ Error message indication
  - ◆ Temperature measurement in the electronic transmitter
  - ◆ HART 5/7- or Profibus PA- Communication

Contents	
Features	page 1
Standard Specifications	page 2
Hazardous Area Specifications	page 5
Planning and Installation Hints	page 10
Model Specifications	page 11
Options	page 12
Process Connection Table for Metal Tubes	page 14
Flow Table for Metal Tubes	page 15
Process Connection Table for PTFE-Lining	page 16
Flow Table for PTFE-lining	page 16
Temperature Limitations, Standard and Intrinsically Safe	page 17
Minimum Ambient Temperature	page 18
Pressure Temperature (PT)-Rating	page 19
Dimensions and Weights	page 20

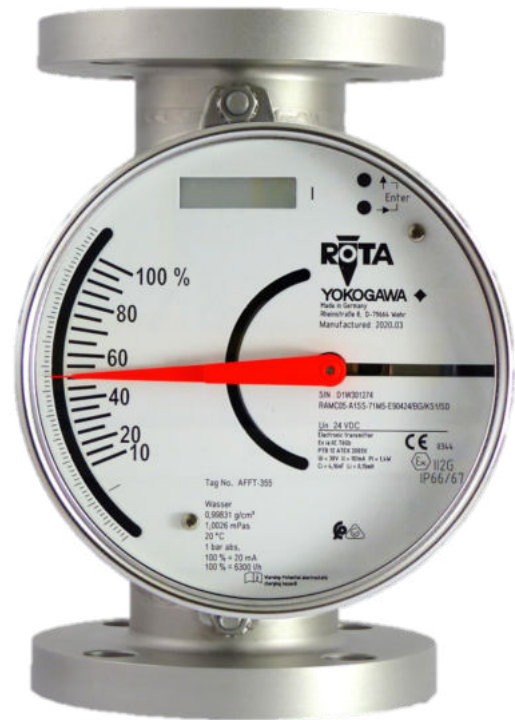

RAMC with housing type 90

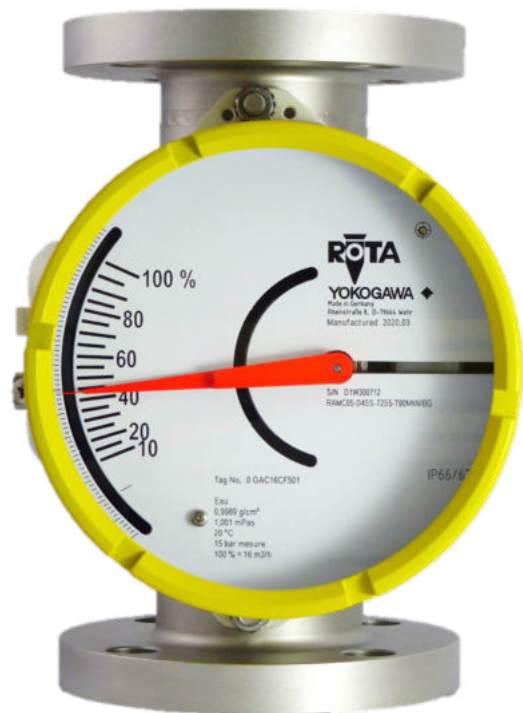

RAMC with housing type 91

## STANDARD SPECIFICATIONS

### RoHS Directive 2011/65/EU, 2015/863/EU:

RoHS conform according to EN IEC 63000

### MEASURING TUBE

#### Materials of wetted parts:

- Stainless steel 1.4401/1.4404 (316/316L)
- PTFE (if selected)
- Gasket for process connection R4 or T4:  
Aramide fibres with NBR binder
- Other materials on request: e.g. Nickel base alloys, titanium, etc.

#### Fluids to be measured:

Clean liquids, gas and steam

#### Measuring range:

The measurable flow rates are depending from density and viscosity of the fluid. To find the fluid specific measuring range please use the Yokogawa Sizing Software: [www.FlowConfigurator.com](http://www.FlowConfigurator.com)

#### Measuring turndown ratio:

10:1

#### Process connections in stainless steel:

Flanges:

- Acc. to EN 1092-1
  - DN100 to DN150 PN16
  - DN15 to DN100 PN40
  - DN50 to DN80 PN63
  - DN15 to DN50 PN100
- Acc. to ASME B 16.5 (AISI 316/316L dual certified)
  - ½ in. to 6 in. Class 150 raised face
  - ½ in. to 6 in. Class 300 raised face
  - ½ in. to 3 in. Class 600 raised face
- Flange facing roughness
  - Form B1: Ra 3.2 to 6.3 µm
  - Form B2: Ra 0.8 to 3.2 µm
  - ASME: Ra 3.2 to 6.3 µm
- Threaded connection:
  - External thread acc. to DIN11851
  - Internal thread NPT
  - Internal thread G
  - Clamp: DN25, 1 in. to DN100, 4 in.

#### Process pressure:

Depends on process connection, see table 10, 11 and 12 higher pressure up to 700 bar (10152 psi) on request

#### Process temperature:

- Wetted parts made of stainless steel:  
-196 °C to +370 °C (-320.8 °F to 698 °F)
- Wetted parts made of PTFE:  
-80 °C to +130 °C (-112 °F to 266 °F)

See fig. 1a to fig. 1c

#### Measuring accuracy at calibration conditions:

Table 1

Material of wetted parts	Size	Measuring accuracy acc. standard VDI/VDE 3513 sheet 2 ( $q_G=50\%$ )
SS	DN15 to DN100	1.6 %
SS	DN125 to DN150	2.5 %
PTFE	DN15 to DN100	2.5 %

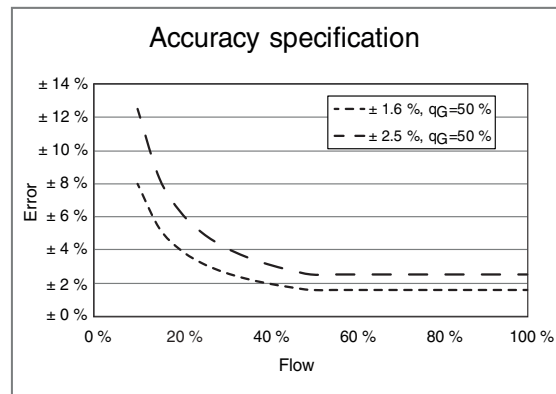

#### Calibration conditions:

Water, 1 to 2 bar, +15 °C to +25 °C (59 °F to 77 °F)

#### Pressure Equipment Directive (PED):

- Tubes:
  - Modul: H
  - Fluid Group: 1 (dangerous fluids)
  - Produced acc. to category: III
  - Classification: Table 6 of PED directive (piping)
- Heating (options /T1 to /T6):
  - Art. 4 section 3: (Volume < 1 L)
  - Fluid Group: 2 (non-dangerous fluids)
  - Classification: Table 2 of PED directive (vessels)

#### Installation:

- Mounting direction:  
vertical
- Flow direction:  
upwards
- Mounting length:  
see table 10, 11 and 12
- Straight pipe inlet/outlet length:  
Only for sizes  $\geq$  DN80 (3 in.)  
Inlet: at least 5D  
Outlet: at least 3D

#### Weight:

See table 19

#### Canadian Registration Numbers (CRN)

Available upon request, only in combination with option /P15 or /P16

### MECHANICAL INDICATOR, type -T

#### Principle:

The flow value is indicated by a pointer with the aid of a magnet enclosed in the float and a magnet in the indicator unit which follows the movements of the float.

#### Indicator housing:

- Materials:
  - Housing type 90: stainless steel 1.4404/316L
  - Housing type 91: aluminum, Polyurethane, yellow, RAL 1021 acc. to EN 13195 material: AC 44200
  - Both housing types with safety-glass window
- Degree of protection:
  - IP66/67
  - NEMA 4, 4X, 6 (not for Ex d housing)

#### Scales:

- Standard:  
removable aluminum plate with scale  
(double scale as option)
- Marking:  
direct readable units or percentage of  $Q_{max}$ \*

#### Transportation- and Storage condition:

-40 °C to +110 °C (-40 °F to 230 °F)

**ELECTRONIC TRANSMITTER, type -E, -H, -J, -P****Standard type -E:**

- **Power supply:**
    - 4-wire units with galvanic isolation:
      - 230 V AC +10 %/ -15 %, 50/60 Hz, fuse 0.063 A, time lag, 5x20 mm
      - 115 V AC +10 %/ -15 %, 50/60 Hz, fuse 0.125 A, time lag, 5x20 mm
    - 2/3-wire units: U = 14 to 30 V DC
  - **Output signal:**
    - 4-wire units:
      - 0 to 20 mA
      - 4 to 20 mA
      - Pulse output (option /CP): max. frequency 4 Hz
    - 3-wire units:
      - 0 to 20 mA
      - 4 to 20 mA
    - 2-wire units: 4 to 20 mA
- The 20 mA point is selectable between 60 % and 100 % of scale end value.
- **Load resistance:**
    - 4-wire units:  $\leq 500 \Omega$
    - 2/3-wire unit:  $\leq (U - 14 \text{ V}) / 20 \text{ mA}$ , max. 500  $\Omega$

**HART-communication type -H, -J:**

- **Power supply:**
  - 2-wire units: U = 14 to 30 V DC
- **Output signal:**
  - 2-wire units: 4 to 20 mA
- **Load resistance:**
  - HART-version: 230 to 500  $\Omega$

**Profibus PA-communication type -P:**

- 2-wire bus connection not polarity sensitive
- AI block: Volume flow or mass flow
- TB block: Flow transducer block
- Profile version 3.02:
  - Condensed Status (NE 107)
  - Life Cycle Management (Automatic IDENT\_ NUMBER adaption)
- DP-V0: AI x 1
- IDENT\_NUMBER:
  - 0x0A45 (manufacturer specific)
  - 0x9700 (profile specific)
- Conditions of communication line:
  - Supply voltage from bus: 9 to 32 V DC
  - Current draw: 14 mA
- Failure current (FDE): 10 mA additional to basic current @RT
- Transmission rate: 31.25 kbit/s
- Supports I&M- functions

**Digital display:**

8 digits, 7 segment LC-display character height 6 mm

**Process-/ Ambient temperature:**

The dependency of the process temperature from the ambient temperature is shown in fig. 1a to fig. 1c.

The internal temperature of the electronic transmitter can be indicated on the display or checked via communication protocols HART and Profibus PA

**Measurement of the internal transmitter temperature:**

- Range: -25 °C to +70 °C (-13 °F to 158 °F)
- Accuracy:  $\pm 5 \text{ }^\circ\text{C}$

**Transportation- and Storage condition:**

-40 °C to +70 °C (-40 °F to 158 °F)

**Linearity<sup>1)</sup>:**

$\pm 0.2 \text{ } \%$  of 20 mA

**Hysteresis<sup>1)</sup>:**

$\pm 0.1 \text{ } \%$  of 20 mA

**Repeatability<sup>1)</sup>:**

$\pm 0.1 \text{ } \%$  of 20 mA

**Influence of power supply<sup>1)</sup>:**

$\pm 0.1 \text{ } \%$  of 20 mA

<sup>1)</sup> referenced to 20 °C ambient temperature

**Temperature coefficient of the output signal<sup>1)</sup>:**

$\pm 0.5 \text{ } \%$  /10 °C of 20 mA

**AC-part of output signal<sup>1)</sup>:**

$\pm 0.15 \text{ } \%$  of 20 mA

**Long-term stability<sup>1)</sup>:**

$\pm 0.2 \text{ } \%$  per year

**Max. output signal:**

21.5 mA

**Output signal in case of failure:**

$\leq 3.6 \text{ mA}$  (acc. NE 43)

**Response time (99 %):**

About 1.5 s with damping 1 s

**Electromagnetic compatibility (EMC):**

- Acc. EN 61326-1, Class A, Table 2 and EN 61326-2-3: Criterion A, restriction: HF-immunity between 500 MHz and 750 MHz: criterion B
  - For Profibus PA type additional acc. EN 61326-2-5
  - Approval for Morocco: Rotameter RAMC complies with the provisions of the Moroccan Regulations:
    - EN 61326 1
    - EN 61326 2 3
- Logo shown on the name plate (scale)

**Device safety acc. EN 61010-1:**

- Over voltage category: II (acc. to EN 60664-1)
- Pollution degree: I
- Safety class:
  - 115 V, 230 V AC: I
  - 24V DC: III

**POWER SUPPLY FOR ELECTRONIC TRANSMITTER, option /UT****Type:**

Power supply with galvanically separated input and output; RN221N-B1, HART-compatible

**Supply voltage:**

20 to 250 V DC/AC 50/60 Hz

**Maximum load:**

700  $\Omega$

**Output signal:**

4 to 20 mA

**CABLE GLAND for transmitter -E, -H, -J, -P****Size:**

- Standard: M16x1.5 for housing type 90
- Standard: M20x1.5 for housing type 91
- Option /A13: thread M20x1.5
- Option /A5: thread  $\frac{1}{2}$  - 14 NPT

**Cable diameter:**

6 to 9 mm (0.24 to 0.35 in.)

**Maximum cross section of core:**

$\varnothing 1.5 \text{ mm}^2$  (0.023 in.<sup>2</sup>)

**LIMIT SWITCHES IN STANDARD VERSION,****option /K1 to /K3****Type:**

Inductive proximity switch SC3.5-N0  
acc. to EN 60947-5-6

**Nominal voltage:**

8 V DC

**Output signal:**

$\leq 1 \text{ mA}$  or  $\geq 3 \text{ mA}$

**LIMIT SWITCHES IN FAIL-SAFE VERSION,****option /K6 to /K10****Type:**

Inductive proximity switch SJ3.5-SN; SJ3.5-S1N  
acc. to EN 60947-5-6

**Nominal voltage:**

8 V DC

**Output signal:**

$\leq 1 \text{ mA}$  or  $\geq 3 \text{ mA}$

## HYSTERESIS OF LIMIT SWITCHES

### Min-contact/ Max-contact:

- Pointer movement:  $\approx 0.8$  mm (0.03 in.)
- Float movement:  $\approx 0.8$  mm (0.03 in.)

### Minimum distance between 2 contacts:

$\approx 2$  mm (0.08 in.)

## CABLE GLAND, option /K1 to /K10

### Size:

- Standard: M16x1.5 for housing type 90
- Standard: M20x1.5 for housing type 91
- Option /A13: thread M20x1.5
- Option /A5: thread  $\frac{1}{2}$  - 14 NPT

### Cable diameter:

6 to 9 mm (0.24 to 0.35 in.)

### Maximum cross section of core:

$\varnothing 1.5$  mm<sup>2</sup> (0.023 in.<sup>2</sup>)

## POWER SUPPLY FOR LIMIT SWITCHES, option /W□□

### Type:

Acc. to EN 60947-5-6

- KFA5-SR2-Ex\*.W (115 V AC); \* = 1 or 2
- KFA6-SR2-Ex\*.W (230 V AC); \* = 1 or 2
- KFD2-SR2-Ex\*.W (24 V DC); \* = 1 or 2

Fail-safe

- KFD2-SH-Ex1 (24 V DC), 1 channel

### Power supply:

- 230 V AC  $\pm 10$  %, 45 to 65 Hz
- 115 V AC  $\pm 10$  %, 45 to 65 Hz
- 24 V DC  $\pm 25$  %

### Relay output:

1 or 2 potential-free changeover contact(s)

### Switching capacity:

Max. 250 V AC, max. 2 A

### Note:

If fail-safe limit switch option /K6 or /K7 is ordered, for the power supply option /W4E must be selected.  
If fail-safe limit switch option /K8, /K9 or /K10 is ordered, for the power supply option /W4F must be selected.

## SWITCHING LEVELS FOR LIMIT SWITCHES

**Table 2** Limit switch as Min, Max, Min-Max, Min-Min and Max-Max contact in standard version

		Option /K1	Option /K2	Option /K3
Function	Pointer	Signal	Signal	Signal
		SC3,5-N0	SC3,5-N0	SC3,5-N0
MAX	above LV	----	1 mA	1 mA
	below LV	----	3 mA	3 mA
MIN	above LV	3 mA	----	3 mA
	below LV	1 mA	----	1 mA

Note: LV = Limit Value

**Table 3** Limit switch as Min, Max and Min-Max contact in fail-safe version

		Option /K6	Option /K7	Option /K8
Function	Pointer	Signal	Signal	Signal
		SJ3,5-SN	SJ3,5-SN	SJ3,5-SN
MAX	above LV	----	1 mA	1 mA
	below LV	----	3 mA	3 mA
	fail-safe	----	1 mA	1 mA
MIN	above LV	3 mA	----	3 mA
	below LV	1 mA	----	1 mA
	fail-safe	1 mA	----	1 mA

Note: LV = Limit Value

**Table 4** Limit switch as Min-Min contact in fail-safe version

		Option /K9
Function	Pointer	Signal
		SJ3,5-S1N
MIN	above LV	3 mA
	below LV	1 mA
	fail-safe	1 mA
Function	Pointer	Signal
		SJ3,5-SN
MIN	above LV	3 mA
	below LV	1 mA
	fail-safe	1 mA

Note: LV = Limit Value

**Table 5** Limit switch as Max-Max contact in fail-safe version

		Option /K10
Function	Pointer	Signal
		SJ3,5-SN
MAX	above LV	1 mA
	below LV	3 mA
	fail-safe	1 mA
Function	Pointer	Signal
		SJ3,5-S1N
MAX	above LV	1 mA
	below LV	3 mA
	fail-safe	1 mA

Note: LV = Limit Value

## FOLLOWING IEC 61508

RAMC with fail-safe limit switches (/K6 to /K10):

Suitable for application in safety functions up to and including SIL2.

RAMC with standard limit switches (/K1 to /K3):

Suitable for application in safety functions up to and including SIL1.

Details see FMEDA report.

## FOLLOWING ISO 13849-1

Safety Metrics available for:

- RAMC with fail-safe limit switches (/K6 to /K10)
- RAMC with standard limit switches (/K1 to /K3)

Details see FMEDA report.

## APPROVALS IN EAEU AND CIS COUNTRIES

### Eurasian Conformity (EAC)

RAMC complies to applicable Technical Regulations valid in EAEU countries Russia, Belarus, Kazakhstan, Armenia and Kyrgyzstan, option /VE.

- TR CU 004
- TR CU 020
- TR CU 032
- TR CU 012 can be added for hazardous area applications (options /GF1, /GS1, /GC1).

### Pattern Approval certificate of Measuring Instruments

RAMC has Pattern Approval certificates and is registered as a measuring instrument in Kazakhstan, Uzbekistan and Russia.

- Option /QR2 for Kazakhstan
- Option /QR3 for Uzbekistan
- Option /VR for Russia

## HAZARDOUS AREA SPECIFICATIONS

Table 6 Overview hazardous area certified instruments:

Location	Europe				Global	USA / Canada	India	Korea	China	Russia, Belarus, Kazakhstan, Armenia, Kyrgyzstan	Taiwan	UAE			
Certificate	ATEX				IECEX	FM	PESO	KOSHA	NEPSI	EAC	TS				
<b>Electronic transmitter</b>															
Protection	ia	ic	ia/tb	-	ia	ia/tb	IS/NI	ia	-	-	ia	-	-	ia	
Option	/KS1	/KS3	/KS2	-	/ES1	/ES2	/FS1	/KS1+/Q11	-	-	/GS1	-	-	-	
Comments	-	<sup>2)</sup>	<sup>1)</sup>	-	-	<sup>1)</sup>	<sup>3)</sup>	-	-	-	-	-	-	-	
See page	6	6	9	-	6	9	6	6	-	-	6	-	-	6	
<b>Limit switches</b>															
Protection	ia	ic	ia/tb	-	ia	ia/tb	IS/NI	ia	ia	ia	ia	-	-	-	
Option	/KS1	/KS3	/KS2	-	/ES1	/ES2	/FS1	/KS1 + /Q11	/KS1 + /KC	/NS1	/GS1	-	-	-	
Comments	-	<sup>2)</sup>	<sup>1)</sup>	-	-	<sup>1)</sup>	-	-	-	-	-	-	-	-	
See page	7	7	9	-	7	9	7	7	7	7	7	-	-	-	
<b>Complete RAMC</b>															
Protection	db/tb	-	-	db/tb	-	-	-	db	d	ia	d/tD	d	-	d/tb	db/tb
Option	/KF1	-	/KC1	/EF1	-	-	/KF1+/Q11	/EF1+ /KC	/NS1	/NF1	/GF1	/GC1	/EF1	-	
Comments	<sup>5)</sup>	-	<sup>6)</sup>	<sup>5)</sup>	-	-	<sup>5)</sup>	<sup>5)</sup>	-	<sup>5)</sup>	<sup>5)</sup>	<sup>6)</sup>	<sup>5)</sup>	<sup>5)</sup>	
See page	8	-	10	8	-	-	8	8	7	9	8	10	9	8	
<b>Power supplies for intrinsically safe components (see page 10)</b>															
Option /UT	yes	-	-	-	-	-	-	-	-	-	-	-	-	-	
Option /W1A,B	yes	-	yes	yes	yes	yes	yes	yes	no	yes	-	-	-	-	
Option /W2A,B	yes	-	yes	yes	yes	yes	yes	yes	no	yes	-	-	-	-	
Option /W4A,B	yes	-	yes	yes	yes	yes	yes	yes	yes	yes	-	-	-	-	
Option /W4E,F	yes	-	yes	no	no	no	no	no	yes	yes	-	-	-	-	
Notation	IS = Intrinsically Safe; NI = Nonincendive; DIP = Dust Ignition Proof														
Comment <sup>1)</sup>	Dust proof by RAMC housing														
Comment <sup>2)</sup>	For use in zone 2														
Comment <sup>3)</sup>	Same certification for USA and Canada														
Comment <sup>4)</sup>	Only for USA; power supply free selectable														
Comment <sup>5)</sup>	Only with housing 91														
Comment <sup>6)</sup>	Only indicator type -T without limit switches														

## HAZARDOUS AREA APPROVALS FOR ELECTRONIC TRANSMITTER, type -E, -H, -J

### Attention:

The approvals for hazardous areas only apply to the defined conditions according to the temperature class. The maximum ambient temperature of the transmitter or limit switches must not be exceeded by the heat transfer of the liquid.

**Table 7 Entity parameters of electronic transmitter**

Option	Ui in V	Ii in mA	Pi in W	Ci in nF	Li in mH	max. Ta in °C (°F)
/KS1/2/3	30	101	1.4	4.16	0.15	70 (158)
/ES1/2	30	101	1.4	4.16	0.15	70 (158)
/FS1	30	100	1.4	40	0.15	70 (158)
/NS1	30	101	1.4	4.16	0.15	70 (158)
/GS1	30	101	1.4	4.16	0.15	70 (158)

### Intrinsically safe electronic transmitter with ATEX-approval, option /KS1

#### Certificate:

PTB 12 ATEX 2003 X

#### Output signal:

- 4 to 20 mA (2-/3-wire unit)
- 0 to 20 mA (3-wire unit)

#### Explosion proof:

Ex ia IIC T6 Gb; group II; category 2G

#### Entity parameter:

See table 7

### Intrinsically safe electronic transmitter with IECEx-approval, option /ES1

#### Certificate:

IECEx PTB 12.0020 X

#### Output signal:

- 4 to 20 mA (2-/3-wire unit)
- 0 to 20 mA (3-wire unit)

#### Explosion proof:

Ex ia IIC T6 Gb; group II; category 2G

#### Entity parameter:

See table 7

### Intrinsically safe electronic transmitter with ATEX-approval for use in category 3G, option /KS3

#### Output signal:

- 4 to 20 mA (2-/3-wire unit)
- 0 to 20 mA (3-wire unit)

#### Explosion proof:

Ex ic IIC T6 Gc; group II; category 3G

#### Entity parameter:

See table 7

### Intrinsically safe/ nonincendive electronic transmitter with FM-approval (USA + Canada), option /FS1

#### Certificate:

No.: 3027471-/3027471C

#### Output signal:

4 to 20 mA (2-wire unit)

#### Explosion proof:

- Intrinsically safe Cl. I, Div. 1, GP. A, B, C, D T6
- Intrinsically safe Cl. 1, Zone 0, AEx ia IIC T6
- Nonincendive Cl. I, Div. 2, GP. A, B, C, D T6

#### Entity parameter of electronic transmitter:

See table 7

### Intrinsically safe electronic transmitter with PESO-approval (India), option /KS1 with /Q11

Same data as ATEX-certified type, option /KS1.

#### Certificate:

PESO Ref. No.: P442021/1

### Intrinsically safe electronic transmitter with EAC-approval Russia, Belarus, Kazakhstan, Armenia and Kyrgyzstan, option /GS1

#### Certificate:

RU C-DE.AA87.B.00398/20

#### Output signal:

- 4 to 20 mA (2-/3-wire unit);
- 0 to 20 mA (3-wire unit)

#### Explosion proof:

1Ex ia IIC T6 Gb X

#### Entity parameter:

See table 7

### Intrinsically safe electronic transmitter with ECAS-approval (UAE)

Same data as for IECEx certification, option /ES1.

#### Certificate:

20-04-10405 / E20-04-000725

## HAZARDOUS AREA APPROVALS FOR ELECTRONIC TRANSMITTER, type -P

**Intrinsically safe electronic transmitter with ATEX-approval**, option /KS1  
**IECEX approval**, option /ES1

**Certificates:**

- PTB 12 ATEX 2003 X
- IECEX PTB 12.0020 X

**Output signal:**

- Profibus PA

**Explosion proof:**

- Variant #1: Ex ia IIB/IIC T4 Gb
- Variant #2: Ex ia IIB/IIC T6 Gb
- Variant #3: Ex ia IIB T6 Gb
- Variant #4: Ex ia IIB/IIC T4 Gb

**Ambient temperature:**

- Variant #1: -40 °C to +70 °C
- Variant #2: -40 °C to +50 °C
- Variant #3: -40 °C to +60 °C
- Variant #4: -40 °C to +70 °C

**Intrinsically safe parameter:**

**Table 8a Variant #1 and #2 (Fuse 32 mA)**

	Fieldbus IIB	Fieldbus IIC	FISCO
Ui	17.5 V	24 V	According to IEC 60079-11: 2011 Annex G
Ii	380 mA	250 mA	
Pi	1.31 W	1.31 W	
Ci	negligible	negligible	
Li	negligible	negligible	

**Table 8b Variant #3 (Fuse 32 mA)**

	Fieldbus IIB	Fieldbus IIC	FISCO
Ui	17.5 V	---	According to IEC 60079-11: 2011 Annex G
Ii	380 mA	---	
Pi	0.95 W	---	
Ci	negligible	---	
Li	negligible	---	

**Table 8c Variant #4 (Fuse 62 mA)**

	Fieldbus IIB	Fieldbus IIC	FISCO
Ui	17.5 V	24 V	According to IEC 60079-11: 2011 Annex G
Ii	380 mA	250 mA	
Pi	2.53 W	2.53 W	
Ci	negligible	negligible	
Li	negligible	negligible	

## HAZARDOUS AREA APPROVALS FOR INTRINSICALLY SAFE LIMIT SWITCHES, option /K1 to /K10

**Intrinsically safe limit switches with ATEX-approval**, option /K1 to /K10 with /KS1

**Certificate:**

- PTB 99 ATEX 2219X ( SC3.5-NO), /K1 to /K3
- PTB 00 ATEX 2049X (SJ 3.5-S.N), /K6 to /K10

**Explosion proof:**

Ex ia IIC T6, group II category 2G

**Entity parameter:**

See certificate

**Intrinsically safe limit switches with ATEX-approval for use in category 3G**, option /K1 to /K10 with /KS3

**Explosion proof:**

Ex ic IIC T6...T1 Gc

**Entity parameter:**

- See specification of SC3,5-N0 Blue (P&F)\* (/K1 to /K3)
  - See specification of SJ3,5-SN (P&F)\* (/K6 to /K10)
- \* P&F = Pepperl & Fuchs

**Intrinsically safe limit switches with IECEX-approval**, option /K1 to /K10 with /ES1

**Certificate:**

- IECEX PTB11.0091 (SC3.5-NO) (/K1 to /K3)
- IECEX PTB11.0092 (SJ 3.5-S.N) (/K6 to /K10)

**Explosion proof:**

Ex ia IIC T6 Gb

**Entity parameter:**

See certificate

**Intrinsically safe/nonincendive limit switches with FM-approval (USA)**, option /K1 to /K10 with /FS1

**Explosion proof:**

- IS: Cl. I, II, III, Div. 1, Gp. ABCDEFG, T6, Ta = +60 °C,
- NI: Cl. I, Div. 2, Gp. ABCD, T5, Ta = +50 °C, Cl. II, Div. 1, Gp. EFG Cl. III, Div. 1

**Entity parameter:**

- See FM-control drawing 116-0165 for IS
- See FM-control drawing 116-0155 for NI

**Intrinsically safe limit switches with EAC-approval Russia, Belarus, Kazakhstan, Armenia and Kyrgyzstan**, option /K1 to /K10 with /GS1

**Certificate:**

- RU C-DE.AA87.B.00398/20
- RU C-DE.AA87.B.00394 (from Pepperl & Fuchs)

**Explosion proof:**

0Ex ia IIC T6...T1 Gb X

**Entity parameter:**

See certificate

**Intrinsically safe limit switches with NEPSI-approval (China)**, option /K1 to /K10 with /NS1

**Certificate:**

- GYJ16.1391X (/K1 to /K3)
- GYJ16.1392X (/K6 to /K10)

**Intrinsically safe limit switches with PESO-approval (India)**, option /K1 to /K10 with /KS1 and /Q11  
 Same data as ATEX-certified type, option /KS1.

**Intrinsically safe limit switches with KOSHA-approval (Korea)**, option /K1 to /K3 with /KS1 and /KC  
 Same data as ATEX-certified type, option /KS1.

**Certificate:**

13-AV4BO-0353X

## HAZARDOUS AREA APPROVALS FOR COMPLETE ELECTRICAL RAMC

### Intrinsically safe RAMC with NEPSI-approval (China), option /NS1

#### Certificate:

GYJ20.1088X

#### Electronic transmitter:

- Output signal:
- 4 to 20 mA (2-/3-wire unit);
- 0 to 20 mA (3-wire unit)
- Explosion proof: Ex ia IIC T6

#### Ambient temperature:

-40 °C to +70 °C (-40 °F to 158 °F)

#### Entity parameter:

See table 7

#### Limit switches:

- Option /K1 to /K3 data see certificate GYJ16.1391X
- Option /K6 to /K10 data see certificate GYJ16.1392X

### Flame proof and dust proof RAMC with ATEX-approval, option /KF1

#### Certificate:

IBExU 05 ATEX 1086

#### Flame proof:

Ex db IIC T1...T6 Gb

#### Dust proof:

Ex tb IIIC TX Db

Max. surface temperature TX: corresp. process temperature

#### Housing:

Painted aluminum casting, type 91

#### Output signal with electronic transmitter -E, -H, -J:

- 4 to 20 mA (2-/3-wire unit)
- 0 to 20 mA (3-wire unit)

#### Power supply with electronic transmitter -E, -H, -J:

2- or 3-wire unit

#### Limit switches:

Options /K1 to /K10 possible

#### Ambient temperature:

-20 °C to +60 °C (-4 °F to 140 °F)

#### Minimum process temperature:

-20 °C (-4 °F)

#### Threads for cable glands:

- Standard: M20x1.5
- Option /A5: ½ - 14 NPT

#### Temperature classification:

See table 9

### Flame proof and dust proof RAMC with IECEx-approval, option /EF1

#### Certificate:

IECEX IBE12.0007

#### Flame proof:

Ex db IIC T1...T6 Gb

#### Dust proof:

Ex tb IIIC TX Db

TX: max. surface temperature determined by the process temperature

#### Housing:

Painted aluminum casting, type 91

#### Output signal with electronic transmitter -E, -H, -J:

- 4 to 20 mA (2- or 3-wire unit);
- 0 to 20 mA (3-wire unit)

#### Power supply with electronic transmitter -E, -H, -J:

2- or 3-wire unit

#### Limit switches:

Options /K1 to /K10 possible

#### Ambient temperature:

-20 °C to +60 °C (-4 °F to 140 °F)

#### Minimum process temperature:

-20 °C (-4 °F)

#### Threads for cable glands:

- Standard: M20x1.5
- Option /A5: ½ - 14 NPT

#### Temperature classification:

See table 9

### Flame proof and dust proof RAMC with PESO-approval (India), option /KF1 with /Q11

Same data as ATEX-certified type, option /KF1.

#### Certificate:

PESO Ref. No.: P432024/1

### Flame proof RAMC with KOSHA-approval (Korea), option /EF1 with /KC

#### Certificate:

12-AV4BO-0721X

#### Flame proof:

Ex d IIC T1...T6

#### Temperature classification:

See table 9

### Flame proof RAMC with EAC-approval (Russia, Belarus, Kazakhstan, Armenia and Kyrgyzstan), option /GF1

#### Certificate:

RU C-DE.AA87.B.00398/20

#### Flame proof:

1Ex db IIC T1...T6 Gb X

#### Dust proof:

Ex tb IIIC T\*\*°C Db X

Max. surface temperature T\*\*°C: corresp. process temperature

#### Housing:

Painted aluminum casting, type 91

#### Output signal with electronic transmitter -E, -H, -J:

- 4 to 20 mA (2-/3-wire unit)
- 0 to 20 mA (3-wire unit)

#### Power supply with electronic transmitter -E, -H, -J:

2- or 3-wire unit

#### Limit switches:

Options /K1 to /K10 possible

#### Ambient temperature:

-20 °C to +60 °C (-4 °F to 140 °F)

#### Minimum process temperature:

-20 °C (-4 °F)

#### Threads for cable glands:

- Standard: M20x1.5
- Option /A5: ½ - 14 NPT

#### Temperature classification:

See table 9

### Flame proof RAMC with ECAS-approval (UAE)

Same data as for IECEx certification, option /EF1.

#### Certificate:

20-04-10406 / E20-04-000726

### Flame proof and dust proof RAMC with NEPSI-approval (China), option /NF1

#### Certificate:

GYJ18.1039X

#### Flame proof:

Ex d IIC T1~T6 Gb

#### Dust proof:

Ex tD A21 IP67 T80°C

#### Housing:

Painted aluminum casting type 91

#### Output signal with electronic transmitter -E, -H, -J:

- 4 to 20 mA (2-/3-wire unit)
- 0 to 20 mA (3-wire unit)

#### Power supply with electronic transmitter -E, -H, -J:

2- or 3-wire unit

#### Limit switches:

Options /K1 to /K10 possible

#### Ambient temperature:

-20 °C to +60 °C (-4 °F to 140 °F)

#### Minimum process temperature:

-20 °C (-4 °F)

#### Threads for cable glands:

- Standard: M20x1.5
- Option /A5: ½ - 14 NPT

#### Temperature classification:

See table 9

### Flame proof and dust proof RAMC with Taiwan Safety Mark

#### Registration Document:

ML041200702782

Option /EF1 must be selected.

Same data as IECEx-certified type (/EF1)

For export to Taiwan please contact your Yokogawa representative regarding Taiwan Safety Mark.

Table 9 Temperature rating for Ex d devices

Temp. class	Max. Process temperature in °C (°F)		
	No extension	With extension	With extension with insulation
T6	85 (158)	85 (158)	85 (158)
T5	100 (212)	100 (212)	100 (212)
T4	120 (248)	135 (275)	135 (275)
T3	120 (248)	200 (392)	200 (392)
T2	120 (248)	300 (572)	300 (572)
T1	120 (248)	370 (698)	350 (662)

### INTRINSICALLY SAFE COMPONENTS WITH DUST-PROOF

#### Intrinsically safe electronic transmitter with/without limit switches in dust proof indicator ATEX-certified, option /KS2

##### Approval:

- PTB 12 ATEX2003X (Intrinsically safe electronic transmitter)
- PTB 99 ATEX2219X (Intrinsically safe limit switch SC3.5-N0)
- PTB 00 ATEX2049X (Intrinsically safe limit switch SJ 3.5-S.N)
- IBEExU 05 ATEX1086 (Dust proof)

##### Output signal electronic transmitter:

- 4 to 20 mA (2-/3-wire unit)
- 0 to 20 mA (3-wire unit)

##### Explosion proof:

Ex ia IIC T6 Gb

##### Dust proof:

Ex tb IIIC TX Db IP6X

Max. surface temperature TX: corresponding process temperature

##### Entity parameter:

- See table 7 for electronic transmitter (/KS1)
- See certificates for limit switches

##### Housing:

Painted aluminum casting, type 91

##### Ambient temperature:

-20 °C to +60 °C (-4 °F to 140 °F)

##### Minimum process temperature:

-20 °C (-4 °F)

##### Threads for cable glands:

- Standard: M20x1.5
- Option /A5: ½ - 14 NPT

#### Intrinsically safe electronic transmitter with/without limit switches in dust proof indicator IECEx-certified, option /ES2

##### Approval:

- IECEx PTB12.0020X (Intrinsically safe electronic transmitter)
- IECEx PTB11.0091X (Intrinsically safe limit switch SC3.5-N0)
- IECEx PTB11.0092X (Intrinsically safe limit switch SJ 3.5-S.N)
- IECEx IBE12.0007 (Dust proof)

##### Output signal electronic transmitter:

- 4 to 20 mA (2-/3-wire unit)
- 0 to 20 mA (3-wire unit)

##### Explosion proof:

Ex ia IIC T6 Gb

##### Dust proof:

Ex tb IIIC TX Db

Max. surface temperature TX: corresponding process temperature

##### Entity parameter:

- See table 7 for electronic transmitter (/ES1)
- See certificates for limit switches

##### Housing:

Painted aluminum casting, type 91

##### Ambient temperature:

-20 °C to +60 °C (-4 °F to 140 °F)

##### Minimum process temperature:

-20 °C (-4 °F)

##### Threads for cable glands:

- Standard: M20x1.5
- Option /A5: ½ - 14 NPT

## POWER SUPPLIES FOR INTRINSICALLY SAFE COMPONENTS

### Power Supply for the intrinsically safe electronic transmitter, option /UT

#### Type:

Power supply with galvanically separated input and output  
RN221N-B1, HART-compatible

#### Approval:

- ATEX: PTB 00 ATEX 2018
- Other certificates available on request.

#### Supply voltage:

20 to 250 V DC/AC 50/60 Hz

#### Maximum load impedance:

700 Ω

#### Output signal:

4 to 20 mA

#### Control circuit:

Intrinsically safe [Ex ia] IIC; group II; category (1)GD

#### Entity parameters:

See certificate

### Power supply for intrinsically safe limit switches, option /W□□

#### Type:

Acc. to EN 60947-5-6:

- KFA5-SR2-Ex\*.W (115 V AC), \* = 1 or 2
- KFA6-SR2-Ex\*.W (230 V AC), \* = 1 or 2
- KFD2-SR2-Ex\*.W (24 V DC), \* = 1 or 2

Fail-safe:

- KFD2-SH-Ex1 (24 V DC), fail-safe, 1 channel

#### Approvals:

- KFA5-SR2-Ex\*.W: ATEX: PTB 00 ATEX 2081  
FM: ID 3011578  
IECEX: PTB11.0031  
EAC: RU C-DE.EX01.B.00102/19  
NEPSI:GYJ17.1283
- KFA6-SR2-Ex\*.W: ATEX: PTB 00 ATEX 2081  
FM: ID 3011578  
IECEX: PTB11.0031  
EAC: RU C-DE.EX01.B.00102/19  
NEPSI:GYJ17.1283
- KFD2-SR2-Ex\*.W: ATEX: PTB 00 ATEX 2080  
FM: ID 3011578  
IECEX: PTB11.0034  
EAC: RU C-DE.EX01.B.00102/19  
NEPSI:GYJ17.1284
- KFD2-SH-Ex1: ATEX: PTB 00 ATEX 2042  
EAC: RU C-DE.EX01.B.00102/19

#### Control circuit (ATEX):

[Ex ia] IIC; group II; category (1)GD

#### Entity parameter:

See certificate

## HAZARDOUS AREA APPROVALS FOR COMPLETE MECHANICAL RAMC

### ATEX registered RAMC, option /KC1

#### Archive No.:

IBExU 099/15

#### Explosion proof:

II2G Ex h IIC TX Gb

II2D Ex h IIC TX°C Db

TX°C: max. surface temperature determined by the process temperature

#### Ambient temperature:

-40 °C to +90 °C (-40 °F to 194 °F)

#### Max. process temperature

- Standard: +220 °C (428 °F)
- Indicator on distance: +370 °C (698 °F)

### RAMC with EAC-approval, option /GC1

#### Approval:

RU C-DE.AA87.B.00398/20

#### Explosion proof:

- II Gb c IIC T\*\* X
- III Db c IIC T\*\*°C X

#### Max. surface temperature:

T\*\*°C: corresponding process temperature

#### Ambient temperature:

-40 °C to +90 °C (-40 °F to 194 °F)

#### Max. process temperature:

- Standard: +220 °C (428 °F)
- Indicator on distance: +370 °C (698 °F)

## PLANNING AND INSTALLATION HINTS

- The user is responsible for the use of the flowmeters regarding suitability and use as designed.
- The actual operation pressure must be lower as the specified pressure limits of the Rotameter.
- Make sure that the wetted parts are resistant against the process fluid.
- Ambient- and process temperature must be lower than the specified maximum values.
- If dirt accumulation is to be expected, we recommend installing a bypass pipe.
- To avoid float bouncing in case of gas application notice the recommendations of VDI/VDE 3513 Sheet 3.
- To avoid mutual magnetic influence in case of parallel design of several Rotameters please make sure that the distance between the tube middle axes is at least 300 mm. The distance to other ferromagnetic materials should be at least 250 mm.
- Avoid static magnetic fields next to the Rotameter.

#### Specify the following when ordering:

- Model, suffix code and option code
- Fluid name, process temperature, fluid density, process pressure, fluid viscosity
- For gases: condition of the scale (st. or actual)
- Options: Tag No.: customer specific notes

For your special application please use the Yokogawa Sizing Software [www.FlowConfigurator.com](http://www.FlowConfigurator.com).

## MODEL SPECIFICATIONS

Model	Suffix code	Description	Restrictions
RAMC01		Size DN15 (½ in.)	Refer to table 10
RAMC23		Size DN20 (¾ in.)	Refer to table 10
RAMC02		Size DN25 (1 in.)	Refer to table 10
RAMC03		Size DN32 (1 ¼ in.)	Refer to table 10
RAMC04		Size DN40 (1 ½ in.)	Refer to table 10
RAMC05		Size DN50 (2 in.)	Refer to table 10
RAMC06		Size DN65 (2 ½ in.)	Refer to table 10
RAMC08		Size DN80 (3 in.)	Refer to table 10
RAMC09		Size 3 ½ in.	Refer to table 10
RAMC10		Size DN100 (4 in.)	Refer to table 10
RAMC12		Size DN125 (5 in.)	Refer to table 10
RAMC15		Size DN150 (6 in.)	Refer to table 10
RAMCNN		Without measuring tube, only indicator	only as RAMCNN-NNNN-NNNN
Process connection	-D2 -D4 -D5 -D6 -A1 -A2 -A3 -T6 -G6 -R4 -S2 -S4 -T4 -S5 -NN	EN flange PN16, process connection dimension + facing acc. to EN 1092-1 Form B1 EN flange PN40, process connection dimension + facing acc. to EN 1092-1 Form B1 EN flange PN63, process connection dimension + facing acc. to EN 1092-1 Form B2 EN flange PN100, process connection dimension + facing acc. to EN 1092-1 Form B2 ASME flange class 150, process connection dimension + facing acc. to ASME B 16.5 ASME flange class 300, process connection dimension + facing acc. to ASME B 16.5 ASME flange class 600, process connection dimension + facing acc. to ASME B 16.5 Internal thread NPT, PN40 Internal thread G, PN40 Internal thread Rp, removable External thread acc. to DIN 11851 TRI-CLAMP PN10, PN16 acc. to DIN 32676 Internal thread NPT, removable Rosista flange, PN10 Without measuring tube, only indicator	Only with RAMCNN
Material of wetted parts	SS PF NN	Stainless steel PTFE lining Without measuring tube, only indicator	Only with RAMCNN
Cone/Float	-□ □ □ □ -NNNN	See tables 11 and 13 Without measuring tube, only indicator	Only with RAMCNN
Indicator/Transmitter	-T -E -H -J -P -N	Mechanical indicator Indicator with transmitter Indicator with transmitter, HART 5 (includes Software Tag for HART 5) Indicator with transmitter, HART 7 (includes Software Tag for HART 7) Indicator with transmitter, Profibus PA (includes Software Tag for Profibus PA) Without indicator	Only with output 424; 8 digits for tag, 24 digits for long tag Only with output 424 8 digits for tag, 24 digits for long tag Only with output 429; explosion proof type only with /KS1 or /ES1; not with /VR, /Q11, /QRx Only with housing NN
Housing type	90 91 NN	Housing SS Housing Al, yellow painted Without housing	Only with indicator -N
Power supply/Output	240 244 140 144 430 434 424 429 NNN	230 V AC; 4-wire; 0 to 20 mA 230 V AC; 4-wire; 4 to 20 mA 115 V AC; 4-wire; 0 to 20 mA 115 V AC; 4-wire; 4 to 20 mA 24 V DC; 3-wire; 0 to 20 mA 24 V DC; 3-wire; 4 to 20 mA 24 V DC; 2-wire; 4 to 20 mA 9 to 32 V DC; 2-wire; Profibus PA Without power supply	Only with indicator -E; not with limit switches Only with indicator -E; not with limit switches Only with indicator -E; not with limit switches Only with indicator -E; not with limit switches Only with indicator -E Only with indicator -E Only with indicator -E, -H, -J Only with indicator -P Only with indicator -T or -N

## OPTIONS

Options	Code	Description	Restrictions		
Indicator	/A5	Internal thread for cable gland ASME 1/2 - 14 NPT	Not with /A13 Only for indicator -E and -H; not with -J because already available as standard Only for housing 90 Only for housing 90, 91 Not with hazardous approval type; not with indicator; not with /A16; only with measuring tube Not with /KS2, /ES2, /KF1, /EF1, /NF1, /GF1 and housing 91 with /A5 or /A13 Not with /K1, /K2, /K3, /K9, /K10, /KF1, /EF1, /NF1, GF1, /KS2, /ES2, power supply 14□ + 24□, /FS1		
	/A12	US-engineering units			
	/A13	Internal thread for cable gland ISO M20x1.5			
	/A16	Indicator on 95 mm extension			
	/A23	Scale and EEPROM for type E90, H90, J90, P90, E91, H91, J91, P91			
	/A25	Pressure balance element			
	/A26	Indicator for -40 °C (-40 °F) ambient temperature			
Marking	/B0	Tag plate (1.4404/316L) on flange and marking on scale	Plate 9x40 mm; max. 45 digits Plate 9x40 mm; max. 45 digits  Not with hazardous approval type; not with /VR, /VE  Max. 30 digits Adjustment of the transmitter for the first mentioned fluid		
	/B1	Tag plate (SS) fixed by wire and customer specified tag number on scale			
	/B4	Neutral version			
	/B10	Percentage scale			
	/BG	Customer specific notes on scale			
	/BD	Dual scale			
Limit switches	/K1	MIN-contact	Not for power supply 14□ + 24□; not with indicator P Not for power supply 14□ + 24□; not with indicator P Not for power supply 14□ + 24□; not with indicator P Not for power supply 14□ + 24□; not with indicator P Not for power supply 14□ + 24□; not with indicator P Not for power supply 14□ + 24□; not with indicator P Not for power supply 14□ + 24□; not with indicator P Not for power supply 14□ + 24□; not with indicator P Not for power supply 14□ + 24□; not with indicator P		
	/K2	MAX-contact			
	/K3	MIN-MAX-contact, MIN-MIN-contact, MAX-MAX-contact			
	/K6	MIN-contact "fail-safe" version			
	/K7	MAX-contact "fail-safe" version			
	/K8	MIN-MAX-contact "fail-safe" version			
	/K9	MIN-MIN-contact "fail-safe" version			
	/K10	MAX-MAX-contact "fail-safe" version			
	Pulse output	/CP		Pulse output isolated	Only for power supply 140, 144, 240, 244; not with limit switches
	Flange Facing	/D10		Form B2 acc. to EN 1092-1	Only for EN-flanges (D2, D4)
/D11		Form D acc. to EN 1092-1	Only for EN-flanges (D2, D4)		
Damping	/SD	Float damping system	Only for SS; not for cone 81, 82; only for gas application		
Flange protection	/QK	Flange covers	Only for flanges A1, A2, A3, D2, D4, D5, D6		
Heat tracing	/T1	Heat trace connection internal thread G ¼ in. PN40	Heating is only for metallic instruments "SS" available Heating is only for metallic instruments "SS" available Heating is only for metallic instruments "SS" available Heating is only for metallic instruments "SS" available Heating is only for metallic instruments "SS" available Heating is only for metallic instruments "SS" available		
	/T2	Heat trace connection EN flange DN15 PN40 Form B1			
	/T3	Heat trace connection EN flange DN25 PN40 Form B1			
	/T4	Heat trace connection ASME flange ½ in. Class 150 RF			
	/T5	Heat trace connection ASME flange 1 in. Class 150 RF			
	/T6	Heat trace connection internal thread ¼ - 18 NPT PN40			
Housing Coating	/X1	Single layer epoxy coating system for housing type 91; Cover and bottom in green RAL 6004	Not for housing 90; not with /KC1 or /GC1		
	/X2	High Anti Corrosion coating (3 layers) for housing type 91; /A16 will also be coated; Cover in yellow RAL 1021, bottom (and /A16 if selected) in white RAL 9001	Not for housing 90; not with /KC1 or /GC1		
Power supply for electronic transmitter	/UT	RN221N-B1, 20 to 250 V DC/AC, Ex i, HART compatible	Only for indicator -E, -H, -J, only ATEX or standard, only for output 424		
Power supply for limit switches (transmitter relay)	/W1A	KFA5-SR2-Ex1.W/ 115 V AC, 1 channel	Only for limit switches /K1, /K2, /K3; not with indicator P Only for limit switches /K1, /K2, /K3; not with indicator P Only for limit switches /K1, /K2, /K3; not with indicator P Only for limit switches /K1, /K2, /K3; not with indicator P Only for limit switches /K1, /K2, /K3; not with indicator P Only for limit switches /K1, /K2, /K3; not with indicator P Only for limit switches /K1, /K2, /K3; not with indicator P Only for limit switches /K1, /K2, /K3; not with indicator P Only for limit switches /K6, /K7; not with indicator P Only for limit switches /K8, /K9, /K10; not with indicator P		
	/W1B	KFA5-SR2-Ex2.W/ 115 V AC, 2 channel			
	/W2A	KFA6-SR2-Ex1.W/ 230 V AC, 1 channel			
	/W2B	KFA6-SR2-Ex2.W/ 230 V AC, 2 channel			
	/W4A	KFD2-SR2-Ex1.W/ 24 V DC, 1 channel			
	/W4B	KFD2-SR2-Ex2.W/ 24 V DC, 2 channel			
	/W4E	KFD2-SH-Ex1/ 24 V DC, 1 channel, fail-safe			
	/W4F	2x KFD2-SH-Ex1/ 24 V DC, 1 channel, fail-safe			

Options	Code	Description	Restrictions
Test and certificates	/H1	Oil + fat free for wetted surfaces acc. Yokogawa specification	Only for metallic pressurized parts
	/H4	Oil + fat free for wetted surfaces acc. Yokogawa specification + add. control with UV lamp	
	/P2	Certificate of compliance with the order acc. to EN 10204-2.1	
	/P3	Similar to /P2 + Test report acc. to EN 10204-2.2	
	/P6	Material certificate acc. to EN 10204-3.1	
	/PM3	PMI test (3 points: Process connection inlet, measuring tube, process connection outlet)	
	/PP	Pressure test report flow tube acc. to EN 12266-1	
	/PT	Flow table for conversion to other fluids	
	/P9	Dye penetration test acc. to EN ISO 3452-1 at the welding of the process connection, with certificate	
	/P14	Dye penetrant test of flange welding acc. to ASME V	
	/P15	ASME B31.3 compliance NORMAL FLUID SERVICE	
/P16	ASME B31.3 compliance Category M FLUID SERVICE	Only RAMC□-A1SS, RAMC□-A2SS, RAMC□-A3SS; not for /T□; only with /RTA	
/WP	Welding documentation acc. to AD2000 HP2/1	Not for /T□; not with /P15 or /P16	
/WPA	Welding and certificates acc. to ASME BPVC, IX	Not for PTFE; only for /P15, /P16	
/RTA	X-ray test acc. to ASME BPVC, V	Not for PTFE; only for /P15, /P16	
Hazardous area approvals	/KS1	ATEX intrinsically safe "ia"	Only for power supply 424, 430, 434, 429; for indicator -T Only with limit switches;
	/KS2	in combination with /KC: KOSHA intrinsically safe "ia" ATEX intrinsically safe "ia"/ dust proof "tb"	only for indicator T; only with limit switches /K1 to /K3 Only for power supply 424, 430, 434; for indicator -T only with limit switches; only for housing 91
	/KS3	ATEX intrinsically safe "ic" for use in category 3G	Only for power supply 424, 430, 434; for indicator -T only with limit switches;
	/ES1	IECEX intrinsically safe "ia"	Only for power supply 424, 430, 434, 429; for indicator -T only with limit switches
	/ES2	IECEX intrinsically safe "ia"/ dust proof "tb"	Only for power supply 424, 430, 434; for indicator -T only with limit switches; only for housing 91
	/FS1	FM intrinsically safe/ nonincendive electr. transmitter (USA/Canada), FM intrinsically safe/ nonincendive limit switches (USA)	Only for power supply 424 (electronic transmitter); for indicator -T only with limit switches
	/NS1	NEPSI intrinsically safe "ia" (China)	Only for power supply 424, 430, 434; for indicator -T only with limit switches; not with indicator -J; only with /CN
	/GS1	EAC intrinsically safe "ia"	Only for power supply 424, 430, 434; only with /VE or /VR; for indicator -T only with limit switches
	/KF1	ATEX flame proof "db"/ dust proof "tb"	Only for power supply 424, 430, 434; for indicator -T only with limit switches; only with housing 91
	/EF1	IECEX flame proof "db" / dust proof "tb"; in combination with /KC: KOSHA flame proof "d" (Korea)	Only for power supply 424, 430, 434; for indicator -T only with limit switches; only with housing 91
	/NF1	NEPSI flame proof "d"/ dust proof "d" (China)	Only for power supply 424, 430, 434; for indicator -T only with limit switches; only for housing 91; only with /CN
	/GF1	EAC-Ex flame proof "db" / dust proof "tb"	Only for power supply 424, 430, 434; for indicator -T only with limit switches; only for housing 91; only with /VE or /VR
	/KC1	ATEX non-electrical type	Only for indicator -T without limit switches
	/GC1	EAC-Ex non-electrical type	Only for indicator -T without limit switches; only with /VE or /VR
Country-specific delivery	/VE	EAC-mark for EAEU countries	Not with /Q11; not with /B4
	/VR	EAC-mark and Pattern Approval marking for Russia	Not with /Q11; not with /B4
	/KC	KC-mark for Korea	Not with /Q11; for explosion proof see /EF1 and /KS1; not with /B4
	/CN	China RoHS mark	Not with /Q11; not with /B4
Country-specific application	/QR2	Primary verification approval and Pattern Approval valid in Kazakhstan	See page 4, only with /VE
	/QR3	Primary verification approval and Pattern Approval valid in Uzbekistan	See page 4, only with /VE or /VR
	/Q11	PESO intrinsically safe "ia" or PESO flame proof "d"	Only with /KS1 or /KF1; not with /B4
User's Manuals	/IE <sub>n</sub>	Quantity of instruction manuals in English	n = 1 to 9 selectable <sup>1)</sup>
	/ID <sub>n</sub>	Quantity of instruction manuals in German	n = 1 to 9 selectable <sup>1)</sup>
Special order	/Z	Special design must be specified separately. If /Z is selected, several Suffix of Model-Suffix Code can be changed to Z.	

<sup>1)</sup> If no User's Manual is selected, only a DVD with User's Manuals is shipped with the flowmeter.

## PROCESS CONNECTION TABLE FOR METAL TUBES

Table 10

Pos.	Cone	Model	Installation length L in mm (inch)											
			-D2SS-	-D4SS-	-D5SS-	-D6SS-	-A1SS-	-A2SS-	-A3SS-	-S2SS-	-S4SS-	-T4SS- -R4SS-	-T6SS- -G6SS-	-S5SS-
1	43-51	RAMC01	-	250 (9.84)	-	250 (9.84)	250 (9.84)	250 (9.84)	250 (9.84)	-	-	295 (11.61)	295 (11.61)	-
		RAMC23	-	250 (9.84)	-	250 (9.84)	250 (9.84)	250 (9.84)	250 (9.84)	-	-	295 (11.61)	295 (11.61)	-
		RAMC02	-	250 (9.84)	-	260 (10.23)	250 (9.84)	250 (9.84)	260 (10.23)	275 (10.83)	250 (9.84)	-	295 (11.61)	250 (9.84)
		RAMC03	-	250 (9.84)	-	-	250 (9.84)	250 (9.84)	260 (10.23)	-	250 (9.84)	-	-	-
		RAMC04	-	250 (9.84)	-	-	250 (9.84)	250 (9.84)	280 (11.02)	-	250 (9.84)	-	-	-
		RAMC05	-	250 (9.84)	-	-	250 (9.84)	250 (9.84)	280 (11.02)	-	-	-	-	-
2	53-62	RAMC01	-	250 (9.84)	-	250 (9.84)	250 (9.84)	250 (9.84)	250 (9.84)	-	-	295 (11.61)	-	-
		RAMC23	-	250 (9.84)	-	250 (9.84)	250 (9.84)	250 (9.84)	250 (9.84)	-	-	295 (11.61)	295 (11.61)	-
		RAMC02	-	250 (9.84)	-	260 (10.23)	250 (9.84)	250 (9.84)	260 (10.23)	275 (10.83)	250 (9.84)	250 (9.84)	295 (11.61)	250 (9.84)
		RAMC03	-	250 (9.84)	-	-	250 (9.84)	250 (9.84)	260 (10.23)	-	250 (9.84)	-	-	-
		RAMC04	-	250 (9.84)	-	-	250 (9.84)	250 (9.84)	280 (11.02)	-	250 (9.84)	-	-	-
		RAMC05	-	250 (9.84)	-	-	250 (9.84)	250 (9.84)	280 (11.02)	-	-	-	-	-
3	63-64	RAMC02	-	250 (9.84)	-	270 (10.63)	250 (9.84)	250 (9.84)	270 (10.63)	-	-	310 (12.21)	-	250 (9.84)
		RAMC03	-	250 (9.84)	-	270 (10.63)	250 (9.84)	250 (9.84)	270 (10.63)	-	-	-	310 (12.21)	-
		RAMC04	-	250 (9.84)	-	270 (10.63)	250 (9.84)	250 (9.84)	280 (11.02)	-	-	-	310 (12.21)	250 (9.84)
		RAMC05	-	250 (9.84)	270 (10.63)	280 (11.02)	250 (9.84)	250 (9.84)	280 (11.02)	270 (10.63)	250 (9.84)	-	-	-
4	67-72	RAMC05	-	250 (9.84)	260 (10.23)	-	250 (9.84)	250 (9.84)	280 (11.02)	-	-	325 (12.8)	-	-
		RAMC06	-	250 (9.84)	260 (10.23)	-	250 (9.84)	260 (10.23)	280 (11.02)	275 (10.83)	300 (11.81)	325 (12.8)	325 (12.8)	250 (9.84)
		RAMC08	-	250 (9.84)	270 (10.63)	-	250 (9.84)	260 (10.23)	290 (11.41)	275 (10.83)	-	-	-	-
		RAMC10	250 (9.84)	250 (9.84)	-	-	-	-	-	-	-	-	-	-
5	73-77	RAMC08	-	250 (9.84)	270 (10.63)	-	250 (9.84)	260 (10.23)	-	-	-	-	-	-
		RAMC09	-	-	-	-	250 (9.84)	270 (10.63)	-	-	-	-	-	-
		RAMC10	250 (9.84)	250 (9.84)	-	-	250 (9.84)	270 (10.63)	-	300 (11.81)	250 (9.84)	-	-	-
		RAMC12	250 (9.84)	-	-	-	250 (9.84)	280 (11.02)	-	-	-	-	-	-
		RAMC15	250 (9.84)	-	-	-	260 (10.23)	280 (11.02)	-	-	-	-	-	-
6	81-82	RAMC10	250 (9.84)	250 (9.84)	-	-	250 (9.84)	270 (10.63)	-	-	-	-	-	
		RAMC12	250 (9.84)	-	-	-	250 (9.84)	280 (11.02)	-	300 (11.81)	-	-	-	
		RAMC15	250 (9.84)	-	-	-	280 (11.02)	280 (11.02)	-	-	-	-	-	

## FLOW TABLES FOR METAL TUBES

Table 11

Pos.	Measuring range for water and liquids								Measuring range for air and gases						
	Recommended combination				Alternative combination				Recommended combination				Alternative combination		
	Max. flow		Cone-Float-combin.	Pressure loss <sup>1)</sup>	Viscosity <sup>2)</sup>	Cone-Float-combin.	Pressure loss <sup>1)</sup>	Viscosity <sup>2)</sup>	Max. flow			Cone-Float-combin.	Pressure loss <sup>1)</sup>	Cone-Float-combin.	Pressure loss <sup>1)</sup>
	m <sup>3</sup> /h <sup>3)</sup>	gpm <sup>4)</sup>	Code	mbar	mPa*s	Code	mbar	mPa*s	m <sup>3</sup> /h <sup>3)</sup>	m <sup>3</sup> /h i.N. <sup>5)</sup>	scfm <sup>6)</sup>	Code	mbar	Code	mbar
1	0.025	0.11	43 S0	40	10	-	-	-	0.75	0.7	0.44	43 S0	45	-	-
	0.04	0.18	44 S0	40	80	-	-	-	1.2	1.1	0.7	44 S0	45	-	-
	0.063	0.28	47 S0	40	80	-	-	-	1.8	1.7	1.05	47 S0	45	-	-
	0.1	0.44	51 S0	40	80	-	-	-	3	2.8	1.75	51 S0	45	-	-
2	0.13	0.57	53 L1	12	50	-	-	-	4	3.6	2.3	53 L1	13	-	-
	0.16	0.7	-	-	-	53 M1	15	100	5.5	5	3.2	-	-	53 M1	21
	0.22	1.0	54 L1	12	50	-	-	-	-	-	-	-	-	-	-
	0.25	1.1	53 S1	40	100	54 M1	15	50	6.5	6	3.8	54 L1	13	-	-
	0.32	1.4	-	-	-	57 L1	12	50	9	8.5	5	-	-	54 M1	21
	0.4	1.8	54 S1	40	50	57 M1	15	50	10	9	5.7	57 L1	13	-	-
	0.5	2.2	-	-	-	61 L1	12	50	14	13	8	-	-	57 M1	21
	0.63	2.8	57 S1	40	50	61 M1	15	100	16	15	9	61 L1	13	-	-
	0.8	3.5	-	-	-	62 L1	12	50	22	20	12	-	-	61 M1	21
	1.0	4.4	61 S1	40	100	62 M1	15	100	25	23	14	62 L1	13	-	-
	1.6	7.0	62 S1	40	100	-	-	-	34	32	20	-	-	62 M1	21
	2.2	10.1	-	-	-	62 V1	45	50	50	45	28	-	-	62 S1	45
3	1.3	5.7	63 L2	17	50	-	-	-	40	36	23	63 L2	19	-	-
	2.1	9.2	-	-	-	64 L2	17	50	50	47	29	-	-	63 M2	23
	2.5	11.0	63 S2	42	30	64 M2	17	10	60	55	35	64 L2	19	-	-
	4	17.6	64 S2	42	10	-	-	-	85	80	50	-	-	64 M2	23
	6	26.4	-	-	-	64 V2	43	50	120	110	70	-	-	64 S2	47
4	3.2	14	67 L5	13	50	-	-	-	100	90	57	67 L5	16	-	-
	5.0	22	-	-	-	71 L5	13	50	130	120	75	-	-	67 M5	25
	6.3	28	67 S5	47	30	-	-	-	160	150	90	71 L5	16	-	-
	8.5	37	-	-	-	72 L5	13	50	200	180	115	-	-	71 M5	25
	10	44	71 S5	47	5	72 M5	19	5	250	230	140	72 L5	16	-	-
	16	70	72 S5	47	5	-	-	-	340	320	200	-	-	72 M5	25
5	25	110	-	-	-	72 V5	63	5	500	470	290	-	-	72 S5	54
	25	110	73 V8	60	10	-	-	-	550	500	320	73 L8	30	-	-
	40	176	74 V8	60	10	-	-	-	850	800	500	74 L8	30	-	-
6	63	277	77 V8	60	10	-	-	-	1400	1300	800	77 L8	30	-	-
	100	440	81 11	70	10	-	-	-	-	-	-	-	-	-	-
6	130	572	82 11	70	10	-	-	-	-	-	-	-	-	-	-

<sup>1)</sup> Pressure loss at the float with water or air.

<sup>2)</sup> For higher viscosity the specified precision is no more guaranteed.

<sup>3)</sup> Flow is referred to +20 °C (68 °F) and 1 bar abs. (14.5 psi abs.)

<sup>4)</sup> Flow in US Gallons per minute at +70 °F.

<sup>5)</sup> Flow referred to 0 °C (32 °F) and 1.013 bar abs (14.7 psi abs.) at operation conditions of +20 °C (68 °F) and 1 bar abs. (14.5 psi abs.)

<sup>6)</sup> Flow in Standard cubic feet per minute referred to +60 °F and 14.7 psi at operation conditions of +68 °F und 14.5 psi abs.

For your special application please use the Yokogawa Sizing Software [www.FlowConfigurator.com](http://www.FlowConfigurator.com).

## PROCESS CONNECTION TABLE FOR PTFE-LINING

Table 12

Pos.	Cone	Model	Installation length in mm (inch)			
			-D2PF-	-D4PF-	-A1PF-	-A2PF-
2	51-61	RAMC01	-	250 (9.84)	-	-
		RAMC23	-	-	250 (9.84)	250 (9.84)
		RAMC02	-	250 (9.84)	250 (9.84)	250 (9.84)
3	62-63	RAMC02	-	250 (9.84)	-	-
		RAMC03	-	-	250 (9.84)	250 (9.84)
		RAMC04	-	250 (9.84)	250 (9.84)	250 (9.84)
		RAMC05	-	250 (9.84)	-	-
4	64-71	RAMC05	-	250 (9.84)	-	-
		RAMC06	-	250 (9.84)	260 (10.23)	270 (10.63)
		RAMC08	-	250 (9.84)	260 (10.23)	270 (10.63)
5	72-74	RAMC08	-	250 (9.84)	-	-
		RAMC09	-	-	270 (10.63)	270 (10.63)
		RAMC10	250 (9.84)	-	270 (10.63)	270 (10.63)
6	77	RAMC10	250 (9.84)	250 (9.84)	270 (10.63)	270 (10.63)

## FLOW-TABLE FOR TUBES WITH PTFE-LINING

Table 13

Measuring range for water and liquids					Measuring range for air and gases				
Max. Flow		Cone-Float-combination	Pressure loss <sup>1)</sup>	Viscosity <sup>2)</sup>	Max. flow			Cone-Float-combination	Pressure loss <sup>1)</sup>
m <sup>3</sup> /h <sup>3)</sup>	gpm <sup>4)</sup>	Code	mbar	mPa*s	m <sup>3</sup> /h <sup>3)</sup>	m <sup>3</sup> /h i.N. <sup>5)</sup>	scfm <sup>6)</sup>	Code	mbar
0.1	0.45	51 A1	16	50	3.5	3.3	2	51 A1	20
0.16	0.7	52 A1	16	50	5	4.7	2.9	52 A1	20
0.25	1.12	53 A1	16	50	8.5	8	5	53 A1	20
0.4	1.8	54 A1	16	50	13	12	7.5	54 A1	20
0.63	2.8	57 A1	16	50	20	18	11	57 A1	20
1	4.5	61 V1	18	50	34	32	20	61 V1	22
1.6	7	62 A2	20	30	50	47	29	62 A2	25
2.5	11.2	63 A2	20	10	85	80	50	63 A2	25
4	18	63 V2	22	50	-	-	-	-	-
4	18	64 A5	20	30	130	120	75	64 A5	25
6.3	28	67 A5	20	30	200	180	115	67 A5	25
10	45	71 A5	20	5	350	330	200	71 A5	25
16	70	71 V5	22	10	-	-	-	-	-
16	70	72 V8	25	10	500	470	290	72 V8	27
25	110	73 V8	25	10	850	800	500	73 V8	27
40	180	74 V8	25	10	-	-	-	-	-
63	280	77 10	30	10	-	-	-	-	-

<sup>1)</sup> Pressure loss at the float with water or air.

<sup>2)</sup> For higher viscosity the specified precision is no more guaranteed.

<sup>3)</sup> Flow is referred to +20 °C (68 °F) and 1 bar abs. (14.5 psi abs.)

<sup>4)</sup> Flow in US Gallons per minute at +70 °F.

<sup>5)</sup> Flow referred to 0 °C (32 °F) and 1.013 bar abs (14.7 psi abs.) at operation conditions of +20 °C (68 °F) and 1 bar abs. (14.5 psi abs.)

<sup>6)</sup> Flow in Standard cubic feet per minute referred to +60 °F and 14.7 psi at operation conditions of +68 °F und 14.5 psi abs.

For your special application please use the Yokogawa Sizing Software [www.FlowConfigurator.com](http://www.FlowConfigurator.com).

## TEMPERATURE LIMITATIONS, STANDARD AND INTRINSICALLY SAFE

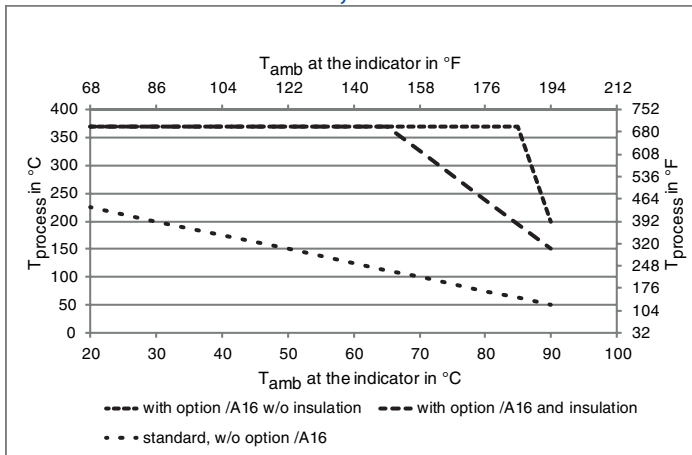

fig. 1a RAMC: Type T90, T91 without limit switch(es) <sup>1)</sup>

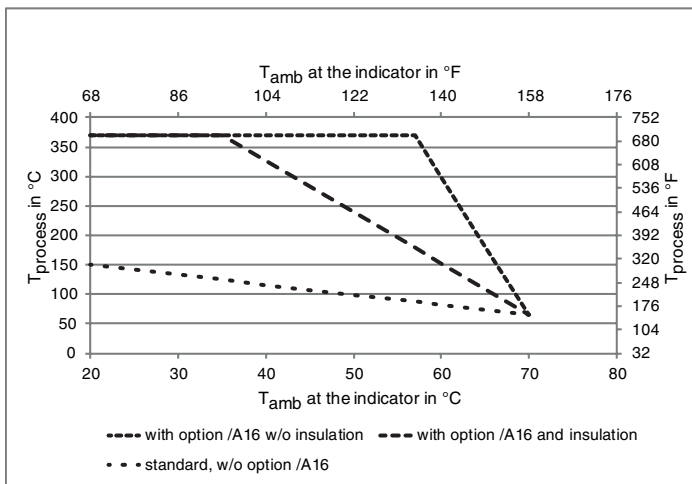

fig. 1b RAMC: Type T90, T91 with limit switch(es), type E90, H90, J90, P90, E91, H91, J91, P91 with/without limit switch(es) <sup>1)</sup>

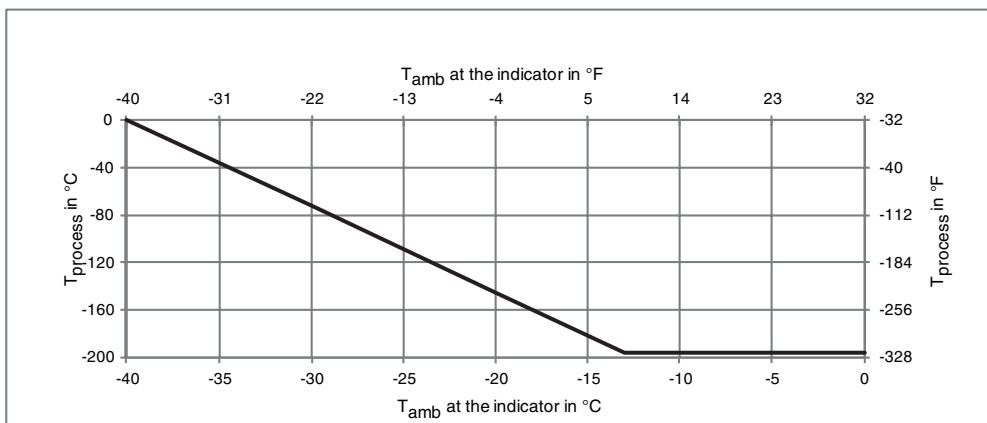

fig. 1c RAMC: All indicator types <sup>1)</sup>

<sup>1)</sup> The temperature graphs are reference values for size DN100. They may be negatively influenced by trapped heat, external heat sources or radiated heat and more optimistic for smaller sizes.  
 Insulation means stone wool between tube and indicator, not touching the indicator. The indicator shall not be insulated.  
 Units with electronic transmitter can show the temperature of the internal transmitter on the display or can be indicated via communication protocols HART and Profibus PA. Units with PTFE-lining are usable up to +130 °C (266 °F).  
 For units with explosion proof certification, the temperature limits according to the certificate of conformity or Control Drawing must be regarded (see also page 5 to 10).



## PRESSURE TEMPERATURE (PT)-RATING

The pressure relevant temperature limits of the RAMC are:

-196 to +400 °C (-320.8 to 752 °F) for units with SS wetted parts

-80 to +130 °C (-112 to 266 °F) for units with PTFE wetted parts.

These limits are reduced by metrological boundary conditions (see temperature curves and table).

Table 15

Process connection		Process pressure p(T) in bar (psi)												
Code	Description	-196 °C (-321 °F)	-80 °C (-112 °F)	RT (68 °F)	50 °C (122 °F)	100 °C (212 °F)	130 °C (266 °F)	140 °C (284 °F)	150 °C (302 °F)	200 °C (392 °F)	250 °C (482 °F)	300 °C (572 °F)	350 °C (652 °F)	400 °C (752 °F)
-A1SS- <sup>1)</sup>	Flange ASME Class 150 RF	19 (275.6)	19 (275.6)	19 (275.6)	18.4 (266.9)	16.2 (235)	15.4 (223.3)	15.1 (219)	14.8 (214.7)	13.7 (198.7)	12.1 (175.5)	10.2 (148)	8.4 (121.8)	6.5 (94.3)
-A2SS- <sup>1)</sup>	Flange ASME Class 300 RF	49.6 (719.4)	49.6 (719.4)	49.6 (719.4)	48.1 (697.6)	42.2 (612)	40 (580)	39.2 (568.5)	38.5 (558.4)	35.7 (517.8)	33.4 (484.4)	31.6 (458.3)	30.3 (439.5)	29.4 (426.4)
-A3SS- <sup>1)</sup>	Flange ASME Class 600 RF	99.3 (1440)	99.3 (1440)	99.3 (1440)	96.2 (1395)	84.4 (1224)	80 (1160.3)	78.5 (1138.5)	77 (1117)	71.3 (1034)	66.8 (968.8)	63.2 (916.6)	60.7 (880.4)	58.9 (824.3)
-D2SS-	Flange EN PN16	16 (232.1)	16 (232.1)	16 (232.1)	15.6 (226.3)	15.1 (219)	14.3 (207.4)	14 (203)	13.7 (198.7)	12.7 (184.2)	11.9 (172.6)	11 (159.5)	10.5 (152.3)	10.2 (148)
-D4SS-	Flange EN PN40	40 (580)	40 (580)	40 (580)	38.9 (564.2)	37.9 (549.7)	35.8 (519.2)	35.1 (509)	34.4 (498.9)	31.8 (461.2)	29.9 (433.7)	27.6 (400.3)	26.4 (397.4)	25.7 (372.7)
-D5SS-	Flange EN PN63	63 (913.7)	63 (913.7)	63 (913.7)	61.5 (892)	59.7 (865.9)	56.5 (819.5)	55.4 (803.5)	54.3 (787.5)	50.1 (726.3)	47.1 (683.1)	43.5 (630.9)	41.7 (604.8)	40.5 (587.4)
-D6SS-	Flange EN PN100	100 (1450)	100 (1450)	100 (1450)	97.8 (1418)	94.7 (1373.5)	89.5 (1298)	87.8 (1273.4)	86.1 (1248.8)	79.5 (1153)	74.7 (1083.4)	69 (1000.7)	66.1 (958.7)	64.2 (931.1)
-T4SS-/R4SS-	Internal thread ½" (RAMC01-...)	25 (362.6)	25 (362.6)	25 (362.6)	25 (362.6)	25 (362.6)	25 (362.6)	25 (362.6)	20 (290)	20 (290)	20 (290)	20 (290)	-	-
-T4SS-/R4SS-	Internal thread ¾" (RAMC23-...)	25 (362.6)	25 (362.6)	25 (362.6)	25 (362.6)	25 (362.6)	25 (362.6)	25 (362.6)	20 (290)	20 (290)	20 (290)	20 (290)	-	-
-T4SS-/R4SS-	Internal thread 1" (RAMC02-...)	16 (232.1)	16 (232.1)	16 (232.1)	16 (232.1)	16 (232.1)	16 (232.1)	16 (232.1)	16 (232.1)	16 (232.1)	16 (232.1)	16 (232.1)	-	-
-T4SS-/R4SS-	Internal thread 2" (RAMC05-...)	10 (145)	10 (145)	10 (145)	10 (145)	10 (145)	10 (145)	10 (145)	10 (145)	10 (145)	10 (145)	10 (145)	-	-
-T4SS-/R4SS-	Internal thread 2½" (RAMC06-...)	10 (145)	10 (145)	10 (145)	10 (145)	10 (145)	10 (145)	10 (145)	10 (145)	10 (145)	10 (145)	10 (145)	-	-
-T6SS-/G6SS-	Internal thread	40 (580.1)	40 (580.1)	40 (580.1)	38.9 (564.2)	37.9 (549.7)	35.8 (519.2)	35.1 (509.1)	34.4 (498.9)	31.8 (461.2)	29.9 (433.7)	27.6 (400.3)	26.4 (382.9)	25.7 (372.7)
-S2SS-	Fitting DIN11851 (RAMC02-...)	-	-	40 (580.1)	40 (580.1)	40 (580.1)	40 (580.1)	40 (580.1)	-	-	-	-	-	-
-S2SS-	Fitting DIN11851 (RAMC05-...)	-	-	25 (362.6)	25 (362.6)	25 (362.6)	25 (362.6)	25 (362.6)	-	-	-	-	-	-
-S2SS-	Fitting DIN11851 (RAMC06-...)	-	-	25 (362.6)	25 (362.6)	25 (362.6)	25 (362.6)	25 (362.6)	-	-	-	-	-	-
-S2SS-	Fitting DIN11851 (RAMC08-...)	-	-	25 (362.6)	25 (362.6)	25 (362.6)	25 (362.6)	25 (362.6)	-	-	-	-	-	-
-S2SS-	Fitting DIN11851 (RAMC10-...)	-	-	25 (362.6)	25 (362.6)	25 (362.6)	25 (362.6)	25 (362.6)	-	-	-	-	-	-
-S2SS-	Fitting DIN11851 (RAMC12-...)	-	-	16 (232.1)	16 (232.1)	16 (232.1)	16 (232.1)	16 (232.1)	-	-	-	-	-	-
-S4SS-	Tri-Clamp DIN 32676 (RAMC02-...)	-	-	25 (362.6)	25 (362.6)	25 (362.6)	25 (362.6)	25 (362.6)	-	-	-	-	-	-
-S4SS-	Tri-Clamp DIN 32676 (RAMC03-...)	-	-	25 (362.6)	25 (362.6)	25 (362.6)	25 (362.6)	25 (362.6)	-	-	-	-	-	-
-S4SS-	Tri-Clamp DIN 32676 (RAMC04-...)	-	-	25 (362.6)	25 (362.6)	25 (362.6)	25 (362.6)	25 (362.6)	-	-	-	-	-	-
-S4SS-	Tri-Clamp DIN 32676 (RAMC05-...)	-	-	16 (232.1)	16 (232.1)	16 (232.1)	16 (232.1)	16 (232.1)	-	-	-	-	-	-
-S4SS-	Tri-Clamp DIN 32676 (RAMC08-...)	-	-	10 (145)	10 (145)	10 (145)	10 (145)	10 (145)	-	-	-	-	-	-
-S4SS-	Tri-Clamp DIN 32676 (RAMC10-...)	-	-	10 (145)	10 (145)	10 (145)	10 (145)	10 (145)	-	-	-	-	-	-
-S5SS-	Flange Rosista (RAMC02-...)	-	-	10 (145)	-	-	-	-	-	-	-	-	-	-
-S5SS-	Flange Rosista (RAMC04-...)	-	-	10 (145)	-	-	-	-	-	-	-	-	-	-
-A1PF-	Flange ASME Class 150 RF	-	19 (275.6)	19 (275.6)	18.4 (266.9)	16.2 (235)	15.4 (210.3)	-	-	-	-	-	-	-
-A2PF-	Flange ASME Class 300 RF	-	49.6 (719.4)	49.6 (719.4)	48.1 (697.6)	42.2 (612)	40 (580.1)	-	-	-	-	-	-	-
-D2PF-	Flange EN PN16	-	16 (232)	16 (232)	15.6 (226.2)	15.1 (219)	14.3 (207.4)	-	-	-	-	-	-	-
-D4PF-	Flange EN PN40	-	40 (580.1)	40 (580.1)	38.9 (564.2)	37.9 (549.7)	35.8 (519.2)	-	-	-	-	-	-	-

<sup>1)</sup> Dual certified AISI 316/316L

**DIMENSIONS AND WEIGHTS**

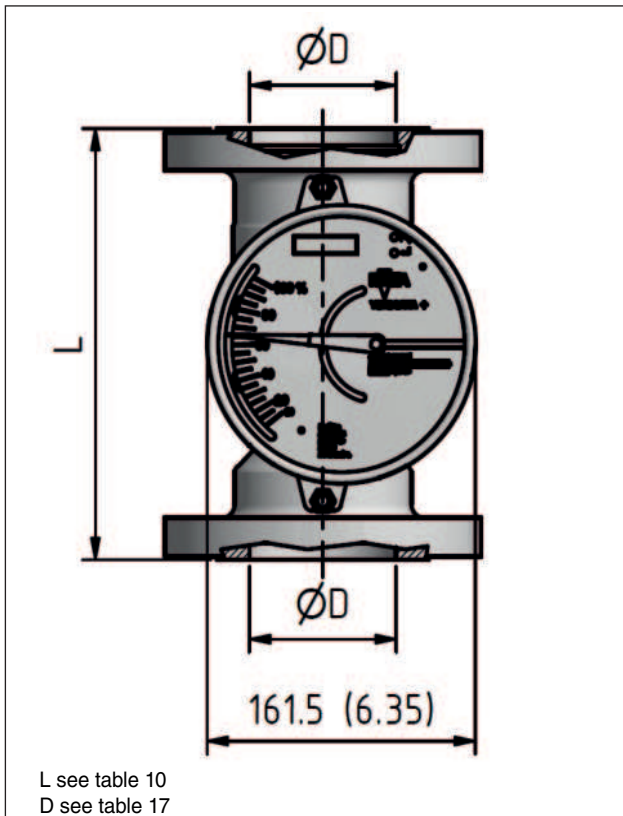

**Fig. 2a Front view housing type 90 (SS) dimensions in mm (inch)**

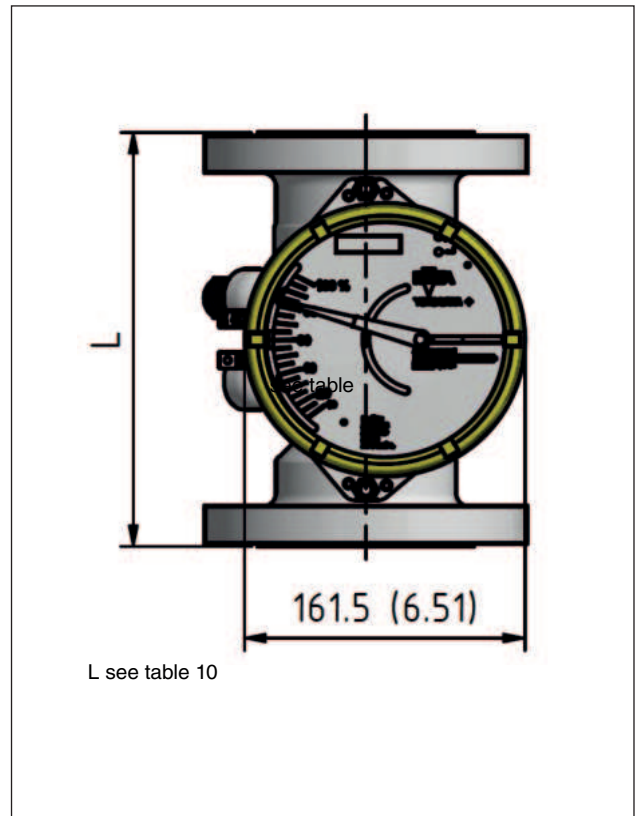

**Fig. 2b Front view housing type 91 (Al) dimensions in mm (inch)**

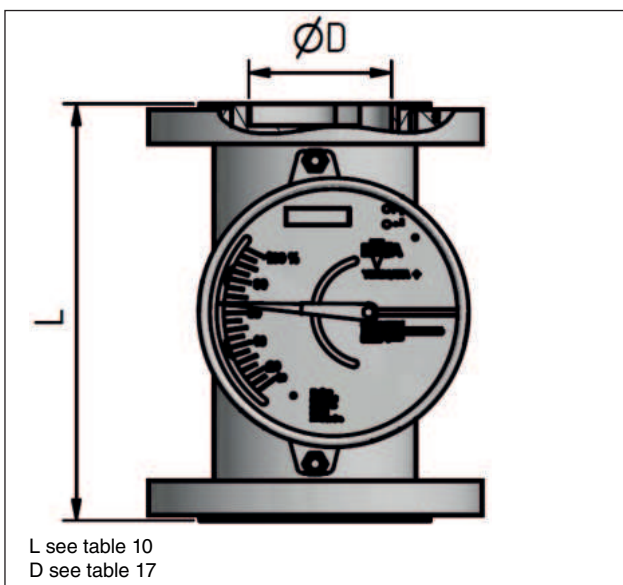

**Fig.3 SS metering tube with PTFE-lining**

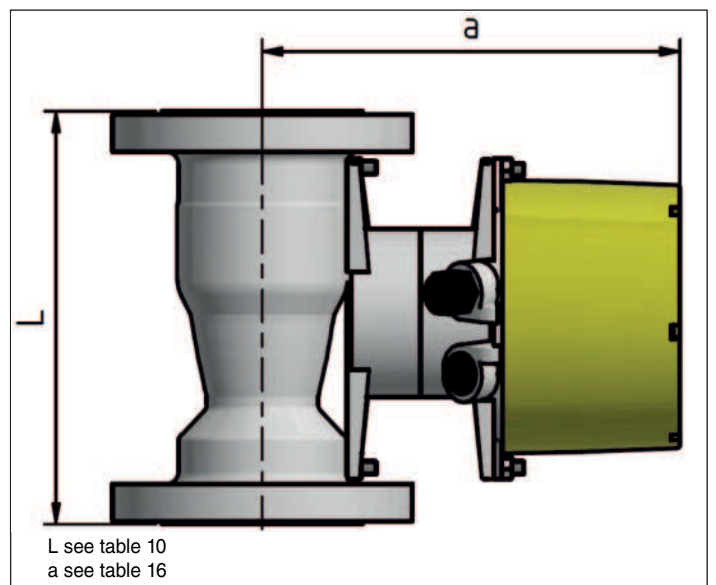

**Fig.4 RAMC type 91 and option /A16**

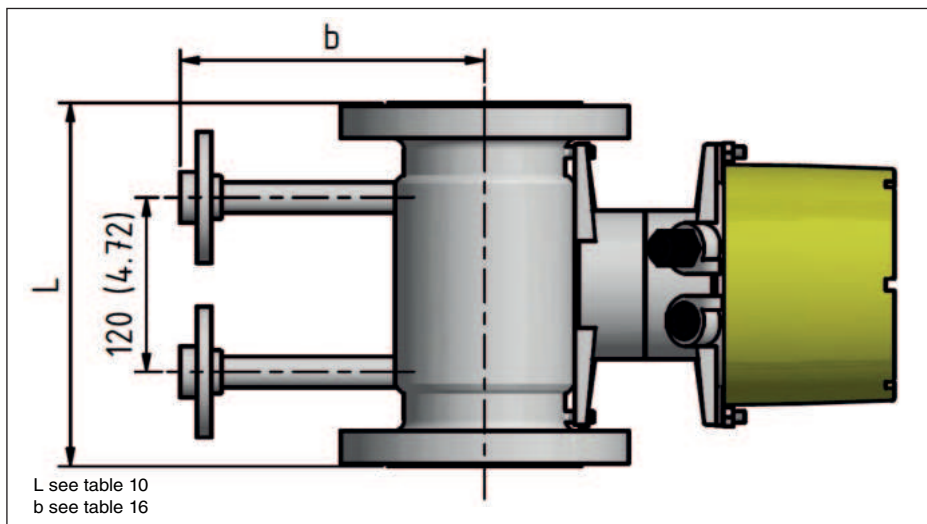

Fig. 5 RAMC type 91 and Option /A16 and /T□, dimensions in mm (inch)

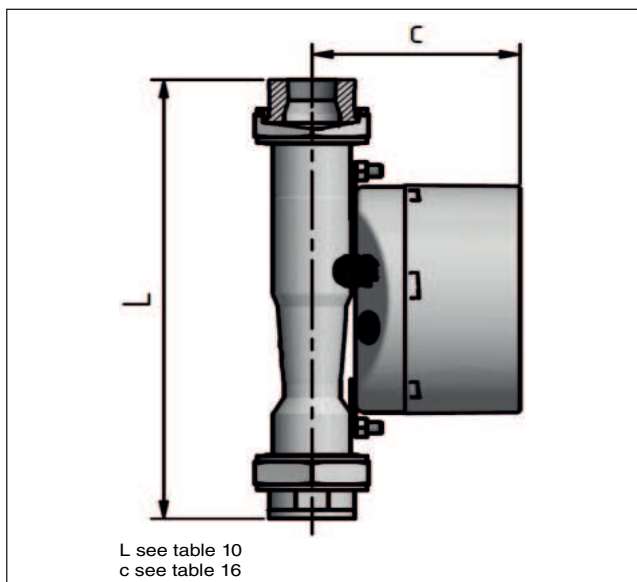

Fig. 6 RAMC with connection R4/T4

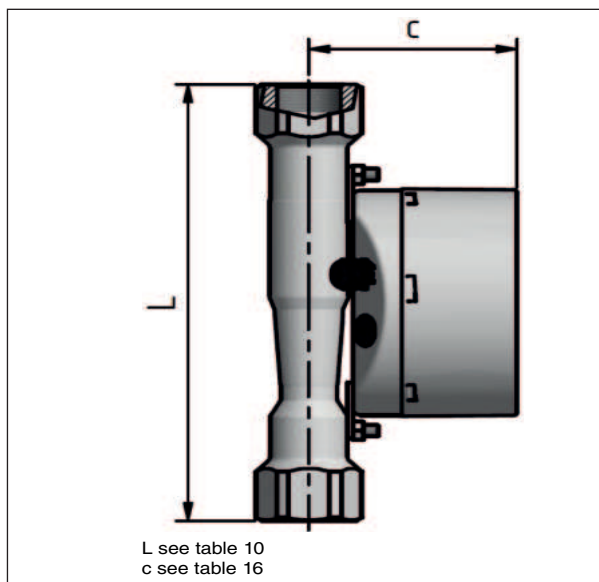

Fig. 7 RAMC with connection T6/G6

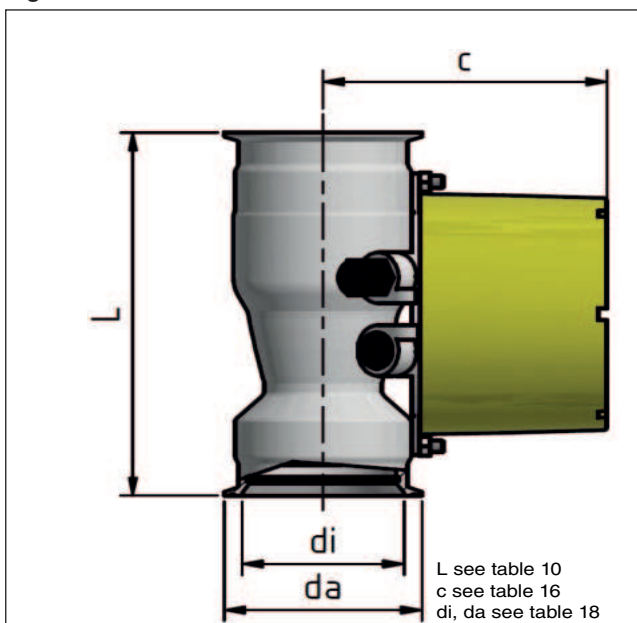

Fig. 8 RAMC with connection S4

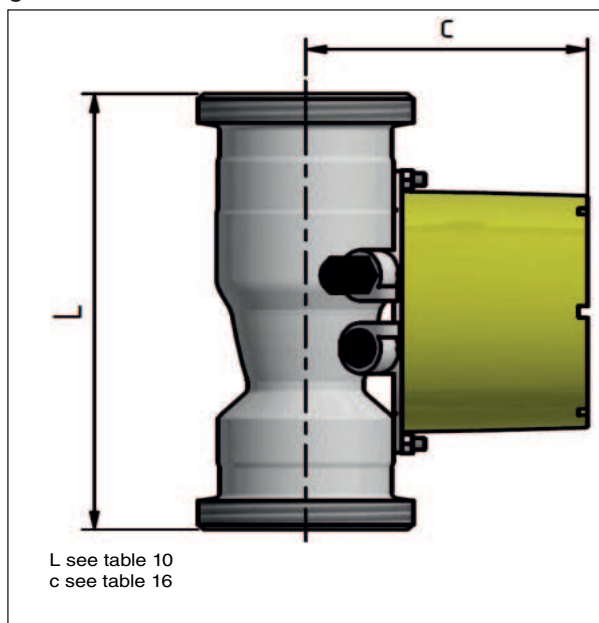

Fig. 9 RAMC with connection S2

Table 16 Variable dimensions

	a in mm (inch)		b in mm (inch)	c in mm (inch)	
	Housing type 90	Housing type 91		Housing type 90	Housing type 91
Cone 43-62	214 (8.42)	228 (8.97)	164.3 (6.46)	120 (4.72)	134 (5.27)
Cone 63-64	221 (8.70)	235 (9.25)	170.8 (6.72)	128 (5.03)	141 (5.55)
Cone 67-72	236 (9.29)	250 (9.84)	189.3 (7.45)	143 (5.62)	156 (6.14)
Cone 73-77	251 (9.88)	265 (10.43)	201.3 (7.92)	158 (6.22)	172 (6.77)
Cone 81-82	261 (10.27)	275 (10.82)	211.5 (8.32)	167 (6.57)	181 (7.12)

Table 17

Inner diameter of stainless steel flanges				Inner diameter of flanges with PTFE-lining			
Pos. <sup>1)</sup>	Size		D in mm (inch)	Pos. <sup>1)</sup>	Size		D in mm (inch)
1	DN15 to DN50	½ to 1 in.	20.7 (0.81)	-	-	-	-
2	DN15 to DN50	½ to 2 in.	20.7 (0.81)	2	DN15 to DN25	¾ to 1 in.	23.5 (0.93)
3	DN25 to DN50	1 to 2 in.	32.2 (1.27)	3	DN25 to DN50	1 ¼ to 1 ½ in.	36 (1.42)
4	DN50 to DN100	2 to 3 in.	65.5 (2.58)	4	DN50 to DN80	2 ½ to 3 in.	66 (2.6)
5	DN80 to DN150	3 to 6 in.	88.2 (3.47)	5	DN80 to DN100	3 ½ to 4 in.	92 (3.62)
6	DN100 to DN150	4 to 6 in.	110.2 (4.34)	6	DN100	4 in.	110 (4.33)

<sup>1)</sup> See table 10, 12

Table 18 Diameters for connection sizes S4

Pos. <sup>1)</sup>	Size	di in mm (inch)	da in mm (inch)
1	DN25, 1 in.	36 (1.42)	50.5 (1.99)
	DN32	36 (1.42)	50.5 (1.99)
	DN40, 1 ½ in.	36 (1.42)	50.5 (1.99)
2	DN25, 1 in.	36 (1.42)	50.5 (1.99)
	DN32	36 (1.42)	50.5 (1.99)
	DN40, 1 ½ in.	36 (1.42)	50.5 (1.99)
3	DN50, 2 in.	47.8 (1.88)	64 (2.52)
4	DN65, 3 in.	72.1 (2.84)	91 (3.58)
5	DN100, 4 in.	97.6 (3.84)	119 (4.69)

<sup>1)</sup> See table 10, 12

Table 19 Weights

Pos. <sup>1)</sup>	Weight in kg (lbs)
1	3 to 5 (6.6 to 11)
2	3 to 5 (6.6 to 11)
3	6.5 to 8 (14.3 to 17.6)
4	8.6 to 11 (18.9 to 24.3)
5	13 to 16 (28.7 to 35.3)
6	17 to 20 (37.5 to 44.1)

<sup>1)</sup> See table 10, 11, 12

Indicator on distance (option /A16) additional 1 kg (2.2 lbs)

## REGISTERED TRADEMARKS

Rotameter® is a trademark of Rota Yokogawa GmbH & Co. KG, a subsidiary of Yokogawa Electric Corporation, Japan.  
In the United Kingdom Rotameter™ is a trademark of Emerson Electric Co.

HART®: Registered trademark of HART® Communication Foundation, Austin, TX, USA

TRI-CLAMP®: Registered trademark of Ladish & Co., Inc., Kenosha, USA

All other company and product names mentioned in this document are trade names, trademarks or registered trademarks of their respective companies. In this document, trademarks or registered trademarks are not marked with ™ or ®.

Manufacturer:

ROTA YOKOGAWA GmbH & Co. KG  
Rheinstr. 8  
D-79664 Wehr  
GERMANY

For the actual manufacturing location of your device refer to the model code and/or serial number.

**COMPANY WITH  
QUALITY SYSTEM  
CERTIFIED BY DNV GL  
= ISO 9001 =**