

setline  
*simple. powerful*



STA / STA<sup>+</sup>



## Setline® by Setaram

Setaram has inspired material scientists for over 70 years with a range of high quality material characterization instruments for even the most challenging experimental conditions. Now Setline brings Setaram's thermal analysis expertise to quality control with a range of instruments designed to meet the most important QC needs and applications.

sta



# SIMPLE

## Setline® is easy to use and easy to own

### EASY TO USE

- Setline® STA / STA<sup>+</sup> is easy to use across diverse QC fields
- Setline's® robust balance and DSC sensor technology ensures quality, consistent and reliable data
- Setline's® compact design is robust and space efficient for all laboratories
- Setline's® STA<sup>+</sup> aut
- Low downtime due to 49 position auto-sampler, fast heat up and cool down.

### EASY TO OWN

- Setline® is built for durability in high use situations
- Cost of ownership is lowered through simplified maintenance for minimized down time and a Replacement Parts Guarantee\*
- Setline's® Technical and Application support ensures fast, expert help on any question
- Calisto 2.0 exclusive software ensures intuitive and easy data handling

## Thermal Analysis and Quality Control

Manufacturers need to meet the increasing demand for product quality and performance.

Product materials and manufacturing processes can both be monitored using thermal analysis to ensure optimal product quality and productivity. It's application within quality control is therefore both broad and numerous and includes polymer, pharmaceutical, cement, steel, battery, textile, carbon and catalyst manufacture to name a few. The early popularity of Setline DSC / DSC<sup>+</sup> systems sees the range now extend into STA / STA<sup>+</sup> systems. STA, or Simultaneous Thermo Analysis enables the coupling of Thermo Gravimetric Analysis (TGA) and Differential Scanning Calorimetry (DSC) for simultaneous measurement of mass variations and heatflow.

With diverse industries and their commercial needs in mind, Setline's® thermal analysis instruments are designed for **simplicity** and **power**.

"During my PhD studies I had to use three different programs to collect and analyze the calorimetric data, and to show graphically the results. Calisto combines all the steps from accurate peak integration to heat capacity determination to even analyze data from other types of equipment."

**Dr Kristina Lilova**  
PhD in Materials Science  
/Solid State Chemistry  
UC Davis, USA



# Setline<sup>®</sup> by Setaram STA and STA<sup>+</sup>

## POWERFUL

**Calisto**  
is designed to treat  
any Thermal Analysis data  
from any instrument or brand, works  
on any Setaram instrument and consists  
of two independent parts:



- **CALISTO ACQUISITION** is dedicated to the control and data acquisition of **SETLINE<sup>®</sup> STA/STA<sup>+</sup>**. It includes the intuitive set-up of experiment procedures that can be saved and reapplied to multiple samples later.
- **CALISTO PROCESSING** is designed for **SETLINE<sup>®</sup> STA/STA<sup>+</sup>** data treatment and includes:
  - Powerful thermal effect processing (single and multiple mass changes, residual mass, DTG, blank subtraction, DSC peak integration, etc)
  - Data integrity features with user rights management options, data modification traceability, secured access etc
  - Automated data processing adapted to your needs with user-recorded macros
    - Options to present data with the maximum impact
    - Direct export to graphical or spreadsheet formats

### Calisto 2.0 Exclusive Software

With quick to install Calisto software Setline's<sup>®</sup> STA and STA<sup>+</sup> are not only **Simple**, they are **Powerful** too.



CALISTO DATA ACQUISITION

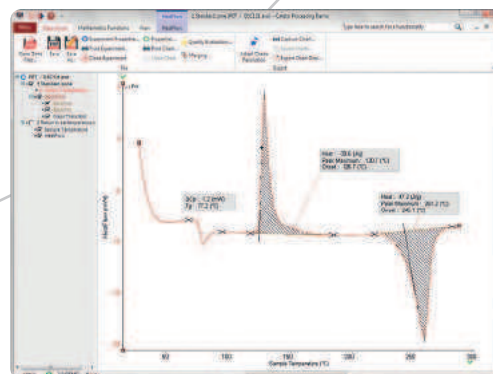

CALISTO DATA PROCESSING

## Applications

The combination of **simplicity** and **power** of SETLINE® STA and STA<sup>+</sup> make them the ideal instruments for intensive use in material quality control testing. Most QC laboratories manage multiple material characterization methods incompatible with complex, user intensive technology and instrument downtime. The robustness and high testing throughput of the STA<sup>+</sup> auto-sampler combined with Calisto's fast and simple data treatment, powered by user-recorded macros, are ideal for QC labs.

### Setline® instruments are designed for the most common S

- Thermal stability, ageing and decomposition pathway of most materials
  - Polymers, elastomers, pharmaceuticals, biomaterials, organic substances like coal, oils, lubricants...
- Compositional analysis:
  - Ashes, carbon, fillers, additives' contents
  - Moisture, solvent contents
- Study of thermal effects like:
  - Pyrolysis, combustion
  - Desorption
  - Dehydration, dehydroxylation

### Just two of many common data representations using Calisto 2.0 software:

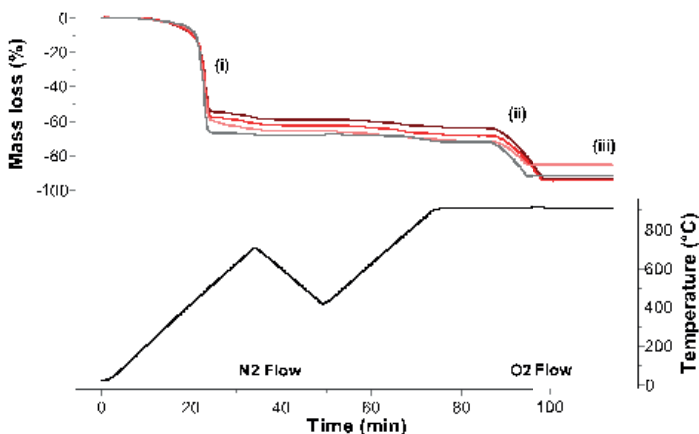

Analysis of the composition of rubber samples of various qualities. The samples are heated in two steps up to 700°C under inert gas flow (nitrogen), cooled down to 400°C and heated back up to 900°C. The gas flow is changed to air at 900°C. The two mass losses observed correspond to the decomposition of the plasticizer and elastomer (i) and the carbon black (ii). The remaining mass at the end of the experiment corresponds to the ash content of the rubber (iii). For the tested lots, (i) varies between 57.7 and 67.7%, (ii) between 4.5 and 5.8%, and (iii) between 19.9 and 29.6%. The 12 mass losses can be treated automatically thanks to a pre-recorded macro.

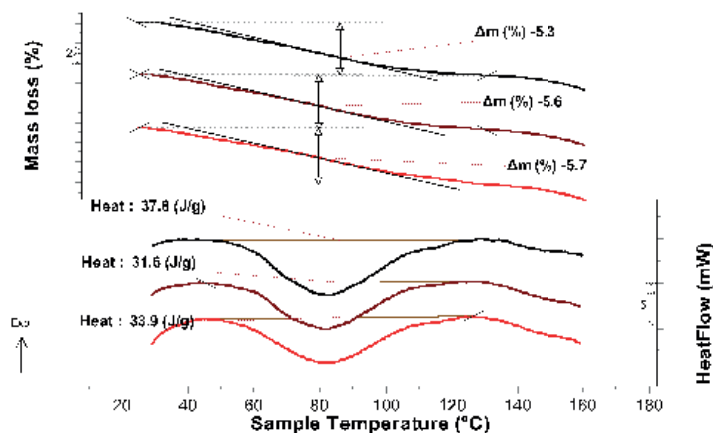

Determination of the free water content of three different lots of a pharmaceutical material using the mass variation signal. The endothermic Heatflow signal enables the identification of the temperature range of the free water release. The mass losses and endothermic peaks can be treated automatically thanks to a pre-recorded macro.

For more information, a free STA Basics and Practical Exercise workbook and extensive application library please refer to:

[www.setaramsolutions.com](http://www.setaramsolutions.com)

## Features

### DSC SENSOR

The DSC transducer of the Setline® STA / STA+ is made from platinum alloys and uses plate-shaped DSC rod technology ensuring high sensitivity over the full temperature range (room temperature to **1 100 °C**).

### BALANCE

The balance used to measure sample mass variations is based on the proven technique of a beam articulated around a torsion band, the most appropriate design for a stable and robust system. It guarantees reliable and sensitive measurements.

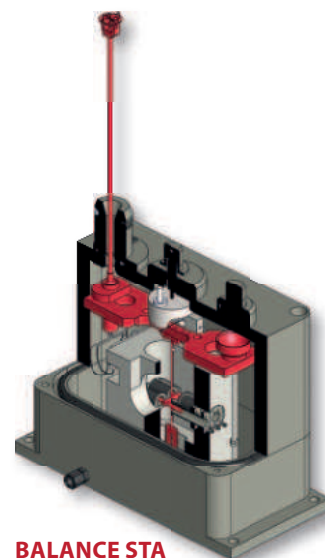

**BALANCE STA**

### CRUCIBLES

We provide finest quality aluminium, alumina and platinum crucibles (80, 90 and 100µl respectively).



## Specifications

	SETLINE® STA	SETLINE® STA <sup>+</sup>
<b>Temperature range (°C)</b>	RT* to 1 100	
<b>Programmable heating rate (°C/min)</b>	0.01 to 50	
<b>Cooling time</b>	45 min from 1 100 °C to 70 °C (air)	
<b>Atmosphere</b>	Inert (N <sub>2</sub> , Ar, He...) or oxidative (Air, O <sub>2</sub> ...)	
<b>Gas flow range (ml/min)</b>	10 to 100	
<b>Mass variation range (mg)</b>	+/- 200	+/- 1 000
<b>Mass variation resolution (µg)</b>	0.05	0.5
<b>DSC rod resolution (µW)</b>	2.5	
<b>Autosampler</b>	-	49 positions (samples or references)
<b>Maximum dimensions Height - Width - Depth (mm) / (in)</b>	600 (closed) or 800 (open) - 400 - 500 / 23.6 (closed) or 31.5 (open) - 15.7 - 19.7	800 - 500 - 650 / 31.5 - 19.7 - 25.6
<b>Power requirements</b>	230V - 50/60Hz	

\*Room Temperature

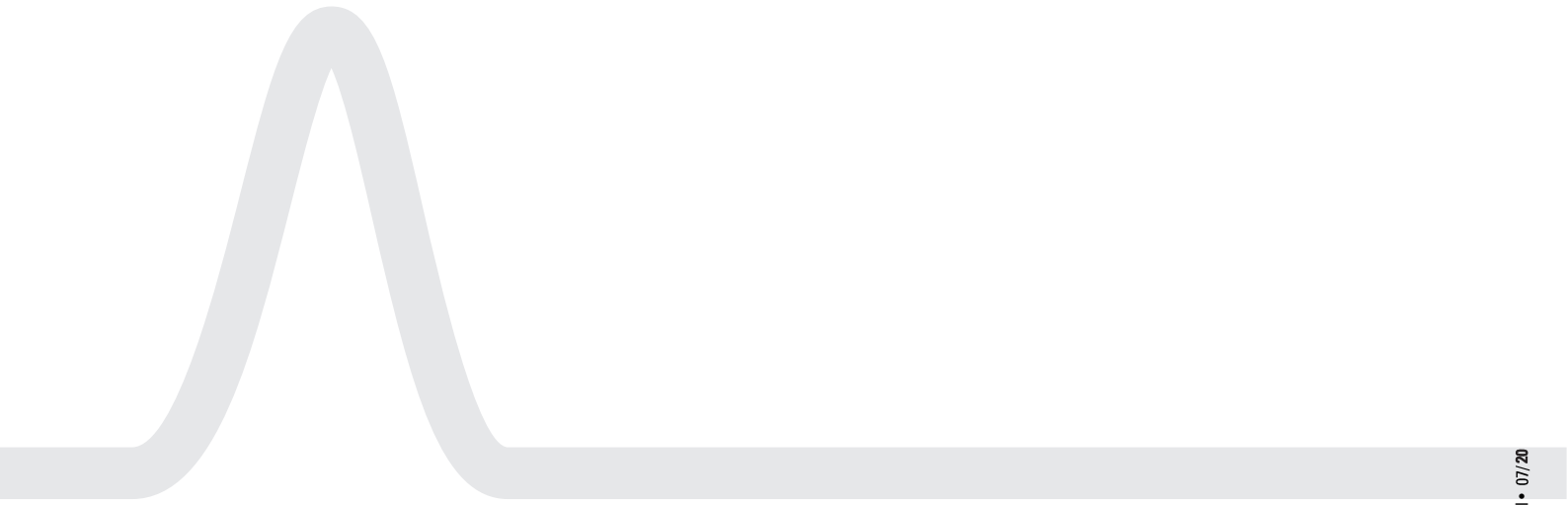

Setline® by Setaram. Unusually Simple. Surprisingly Powerful.

Specifications are given as indications only and are not contractual • 07/20



*simple. powerful*

Switzerland – France – China – United States – India – Hong Kong

For contact details: [www.setaramsolutions.com](http://www.setaramsolutions.com) or [setaram@kep-technologies.com](mailto:setaram@kep-technologies.com)



---

Setaram is a registered trademark of KEP Technologies Group



[www.kep-technologies.com](http://www.kep-technologies.com)