

IKA

designed to work perfectly

EN



DISPERSING, MIXING AND KNEADING MACHINES
PROCESS TECHNOLOGY

Process technology from IKA

/// Designed to work perfectly

Founded in 1910, IKA Werke GmbH & Co. KG in Staufen can look back on more than 110 years of successful company history.

Originally a supplier for laboratories, pharmacies and hospitals, IKA quickly developed into a successful player on the international stage - both in laboratory and analytical technology and in dispersing, mixing and kneading machinery.

Today the IKA Group employs more than 800 people worldwide spread across thirteen sites and four continents.

In recent decades, the Process Technology division has developed into a leading manufacturer of mixing technology and complete systems.

Thanks to constant integration of innovative technologies, the high-quality machines and plants are used in many industries, such as the pharmaceutical, food, chemical, battery and bitumen sectors.

IKA – Quality guarantee

Every machine manufactured by IKA undergoes a rigorous quality check before it leaves our factory.

A functional test and a full inspection ensure rapid implementation and commissioning of every machine at the customer's factory.



9 - 19 INLINE MIXING & DISPERSING

- /// 9 Ultra-Turrax Inline UTL 1000
- /// 11 Ultra-Turrax Inline UTL 2000
- /// 12 Dispax Reactor DR 2000
- /// 13 Dispax Reactor DRS 2000
- /// 14 Colloid Mill MK 2000
- /// 15 Cone Mill MKO 2000
- /// 16 Corundum Disk Mill MCD 2000
- /// 17 Inline Disperser DBI 2000
- /// 18 Solid-Liquid Mixer CMX 2000
- /// 19 Solid-Liquid Mixer MHD 2000



20 - 29 BATCH MIXING, STIRRING & DISPERSING

- /// 22 ULTRA-TURRAX UTC/UTS
- /// 23 ULTRA-TURRAX UTE
- /// 25 ROTOTRON RTS
- /// 26 TURBOTRON RK/RF
- /// 27 TURBOTRON RKG/RFG
- /// 28 TURBOTRON RKG 00-BO



30 STANDS

32 SYSTEMS & PLANTS

- /// 34 magic LAB
- /// 35 Lab Pilot and Process Pilot
- /// 36 magic PLANT
- /// 38 Standard Production Plant SPP
- /// 40 Master Plant MP
- /// 42 Conical Dryer CD
- /// 44 Compact Mixing Plant XPP



Versatility in process technology

/// Virtually unlimited possibilities

The portfolio of machines and plants from IKA covers an exceptionally wide range of mixing technology. Both in terms of the versatility of the applications and the very wide range of sizes and throughputs.

Specialized in solving the most difficult mixing applications for the processing industry, our machines develop and adapt to the specific product application of each individual customer.

Intensive customer care is essential at IKA, from the moment an inquiry is received to the successful commissioning of a machine.

IKA developed the **2000 series** machines. Compared to any other mixing industry model series on the market, this series offers unique solutions for almost all mixing applications. Just to name a few, they include:

- > Wet milling
- > High shear dispersing
- > Solid/liquid mixing

IKA's portfolio covers a complete range of high-end stirring, mixing and dispersing machines that can be used for batch processes and for continuous processes.

Not standing still and always at the cutting edge – that's the IKA philosophy. Continuous, ongoing research and development are vitally important at IKA. New technologies and applications are constantly being tested and developed in close collaboration with customers, universities and research institutes.



Innovation & awards

/// Award-winning innovation

IKA Staufen was once again a TOP 100 Innovator in 2021. This award recognizes exceptionally innovative medium-sized companies. IKA convinced and impressed the experts during the rigorous selection process. It was the fifth time that the manufacturer of laboratory, analysis and process technology has been awarded the coveted prize.

Further proof of IKA's outstanding quality when it comes to machines, plant, and know-how include:

- > 3A approval for the complete line of 2000 series machines from the US Food and Drug Administration (FDA)
- > Continuous ISO certification
- > Large number of patent approvals

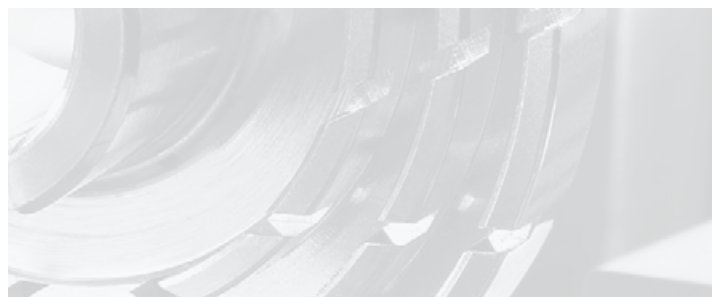

Industries & applications

/// We're your all-rounder for process technology

With our machines and plants, there's virtually no application that can't be done. We're your EXPERTS for process technology in industries such as:

- > Food
- > Chemicals
- > Pharmaceutical & biotechnology
- > Personal hygiene
- > Household products
- > Cosmetics
- > Paper & pulp
- > Paints, pigments and coatings
- > Agriculture
- > Petrochemical & automotive
- > Energy, waste disposal & recycling
- > Electronics
- > Bitumen
- > Battery manufacturing



And more.



Emulsifying – liquid/liquid systems

- > Margarine
- > Ice cream
- > Proteins
- > Creams and lotions
- > Mayonnaise
- > Salad dressings and sauces
- > Microencapsulation
- > Paraffin
- > Cosmetics
- > Mineral oils
- > Silicone oils
- > Pesticides and herbicides
- > Wax



Wet milling/ suspending – liquid/solid systems

- > Titanium dioxide
- > Pigments
- > Metals
- > Polishing agents
- > Seeds
- > Microencapsulation
- > Soot
- > Catalysts/fungicides
- > Graphite
- > Clay
- > Sulfur
- > Crystals
- > Slurry
- > API

In addition, IKA high shear mixers have been tried and tested in many other applications, such as:

- > Decomposing - organic tissue/plants
- > Loosening accumulations
- > Precipitation - dehydration
- > Chemical reactions/gassing
- > Extracting - vortex extraction
- > Shredding/macerating/crushing/pulverizing



Homogenizing – concentrating particle size distribution

- > Flavors and essences
- > Creams
- > Coatings
- > Inks and lacquers
- > Fruit punches
- > Toothpaste
- > Dressings
- > Cheese spreads
- > Jams
- > spice concentrates



Powder – liquid incorporation

- > Starches
- > Fumed silica
- > Milk solids
- > Cellulose
- > Sugar
- > Xanthan and guar gum
- > Carbopol
- > Pigments
- > Fillers
- > Pectines



Dissolving – molecular/colloidal

- > Dyes
- > Crystal powders
- > Salts
- > Cleaning agents
- > Sugar
- > Binding agents
- > Hydrocolloids
- > Elastomers
- > Resins
- > Thixotropic agents

Inline dispersing & solid-liquid mixing

/// The details make all the difference!

A first-class belt drive together with a specific bearing provide an efficient and flexible drive system. A constant circumferential speed and the same design for all sizes guarantee maximum scalability for your processes. Cartridge mechanical seals provide high reliability and easy service.

IKA only uses first-class materials for exceptional mechanical strength and corrosion resistance. We have worked closely with our customers and research institutions to optimize the generators for improved dispersing and efficiency. Our generators (rotor/stator) are also available in many materials other than stainless steel for abrasive and corrosive applications. Our standard inline dispersing machines are already designed with resistant surfaces and have an optimized design for exceptionally easy cleaning.

IKA mixers can be cleaned or steamed in place. The 2000 Series has so many advantages, there are too many to list here.



ULTRA-TURRAX Inline | UTL 1000

/// Inexpensive inline disperser for homogenizing pre-mixes

The economic ULTRA TURRAX UTL 1000 machines are used for homogenizing and dispersing (emulsifying/suspending) pre-mixed liquid-liquid or liquid-solid substances. The machine has a pumping effect which conveys liquids with a viscosity of up to approx. 1,000 mPas. For higher viscosities, the use of a feeding pump is recommended. The dispersing tool is swappable and can be adapted to many different process requirements. The mixing chamber is mounted horizontally and the dispersing tool is directly coupled to the motor shaft.

Example applications

- > Sauces
- > Fruit juices
- > Jams
- > Sugar solutions
- > Dyes
- > Binding agents
- > Molten resins
- > Lotions
- > Adhesives
- > Stabilizers
- > Emulsions
- > Suspensions
- > Deagglomeration

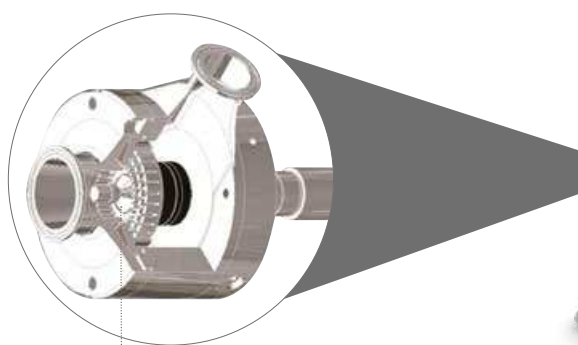

Sizes UTL 1000	Motor power [kW]	Flow rate max. [l/h]	Motor speed [rpm]
UTL 1000/10	7.5	5.500	3,000
UTL 1000/20	22	20.000	3,000
UTL 1000/30	37	40.000	1,500
UTL 1000/40	55	80.000	1,500
UTL 1000/50	110	125.000	1,500

2000 series – excellence is in the detail

/// Modular design for maximum flexibility

The 2000 Series – with a modular design – a system with a great future!

As diverse as the mixing technology and the requirements are in different industries, there are also many similarities. IKA realized this and in response developed a modular machine series. A basic drive unit can be fitted with a large number of different machine heads, providing a solution for almost every mixing application. Our engineers, in cooperation with our customers, combined their expertise to develop the most innovative machine program in the industry!

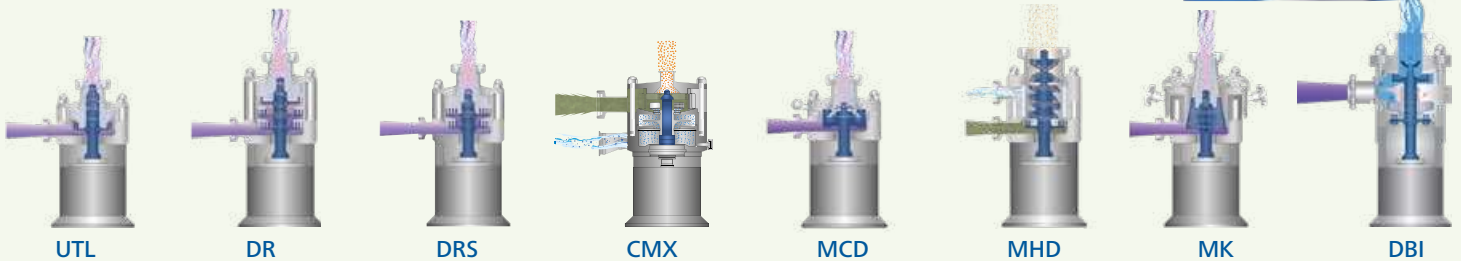

Advantages

- > Self draining thanks to vertical orientation
- > No dead spots
- > Surface finishes meet FDA, 3A and EHEDG requirements
- > GMP compliant versions available
- > Clean-in-place (CIP) and steam-in-place (SIP) compatible versions available
- > Extensive mixing tool options
- > Robust design thanks to a separate bearing assembly
- > Specially adapted designs for pharmaceuticals, food, cosmetics, and chemicals
- > Suitable for high pressures and temperatures
- > High-quality mechanical cartridge seal
- > Simple scalability for all sizes
- > Scale-up support provided by IKA
- > Many certificates/extensive documentation available (e.g. FDA, 3.1 material certificates, IQ/OQ, etc.)



ULTRA-TURRAX Inline | UTL 2000

/// Single-stage dispersing machine

The UTL is a single-stage dispersing machine for producing emulsions and suspensions. A wide variety of rotor-stator combinations (generators) is available to adapt the machine to the application. The UTL runs at the same circumferential speed across all sizes and is therefore very easily scalable. A wide range of options, such as explosion protection (ATEX), different sealing materials and different flange types are available. Thanks to its high-quality surface finish and the design of the dispersing chamber, the ULTRA-TURRAX is easy to clean. The machine empties itself and is suitable for cleaning in place (CIP).

Example applications

- > Sauces
- > Fruit juices
- > Jams
- > Sugar solutions
- > Dyes
- > Binding agents
- > Molten resins
- > Lotions
- > Adhesives
- > Stabilizers
- > Emulsions
- > Suspensions
- > Deagglomeration



Sizes UTL 2000	Motor power [kW]	Flow rate* max. [l/h]	Motor speed [rpm]	Circumferential speed [m/s]
UTL 2000/03 (magic LAB)	0.9	130	15,000	23
UTL 2000/04 (Process/Lab Pilot)	1.5	300	3,000	23
UTL 2000/05	4	2,500	3,000	23
UTL 2000/10	7.5	8,000	3,000	23
UTL 2000/20	22	20,000	3,000	23
UTL 2000/30	37	40,000	1,500	23
UTL 2000/40	55	80,000	1,500	23
UTL 2000/50	110	125,000	1,500	23

* Self pumping rate based on H₂O and standard tool configuration

DISPAX REACTOR DR 2000

/// For very fine emulsions and suspensions with a narrow particle spectrum

The DISPAX REACTOR is a three-stage inline dispersing machine for the production of very fine emulsions and suspensions with a narrow particle spectrum. Thanks to the three rotor-stator combinations (generators) connected in series, it is suitable for both recirculation processes and fully continuous operation. The DR line offers the same advantages as the UTL for scalability and sanitary design, and is also ready for CIP and SIP. A wide range of generators is available, so that the machine can be optimally adapted to your application. For the greatest possible flexibility, the generators can also be easily interchanged later on.

Example applications

- > API wet milling
- > Creams
- > Lotions
- > Toothpaste
- > Fruit juices
- > Salt solutions
- > Catalysts/fungicides
- > Lacquers
- > Polymer emulsions
- > Pesticides
- > Herbicides
- > Fungicides



Sizes DR 2000	Motor power [kW]	Flow rate* max. [l/h]	Motor speed [rpm]	Circumferential speed [m/s]
DR 2000/03 (magic LAB)	0.9	80	3,000	23
DR 2000/04 (Process Pilot)	1.5	500	3,000	23
DR 2000/05	7.5	2,500	3,000	23
DR 2000/10	15	8,000	3,000	23
DR 2000/20	37	20,000	3,000	23
DR 2000/30	55	40,000	1,500	23
DR 2000/40	75	80,000	1,500	23
DR 2000/50	160	125,000	1,500	23

* Self pumping rate based on H₂O and standard tool configuration

DISPAX REACTOR DRS 2000

/// Maximum shear rate and maximum energy input

The circumferential speed and the associated shear rate are among the most important factors for achieving the desired dispersion result. The DISPAX REACTOR DRS combines a circumferential speed of ≥ 40 m/s with fine generator geometries and thereby achieves extraordinarily high shear rates. The generator design also provides very high energy inputs, which are required for particularly demanding wet grinding tasks or emulsions below 1μ . The DRS is designed with the same high quality features as the UTL and the DR, and is especially suited to the most demanding applications.

Example applications

- > Vaccines
- > API wet milling
- > Metal-oxide suspensions
- > Inks
- > Printing dyes
- > Deagglomeration of pigments
- > Urea fertilizers (NPK)
- > Lacquers

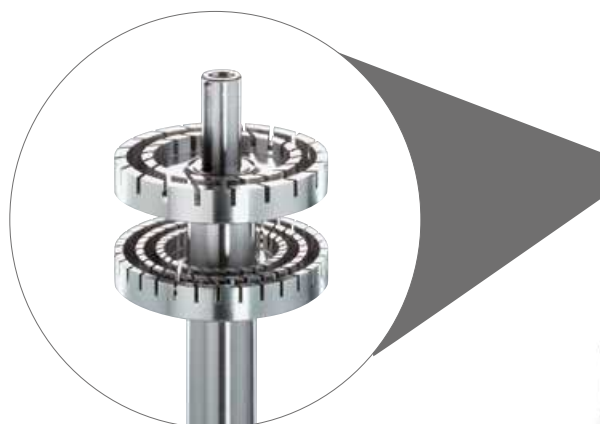

Sizes DRS 2000	Motor power [kW]	Flow rate* max. [l/h]	Motor speed [rpm]	Circumferential speed [m/s]
DRS 2000/03 (magic LAB)	0.9	140	26,000	41
DRS 2000/04 (Process Pilot)	4	380	13,800	41
DRS 2000/05	5.5	700	3,000	40
DRS 2000/10	15	2,500	3,000	40
DRS 2000/20	37	7,000	3,000	40
DRS 2000/30	75	20,000	1,500	40
DRS 2000/50	200	40,000	1,500	40

* Self pumping rate based on H₂O and standard tool configuration

Colloid Mill MK 2000

/// Wet grinding, deagglomeration and production of viscous emulsions

The colloid mill MK 2000 is used especially for wet milling, deagglomeration and the production of viscous emulsions. Its high circumferential speed and the extremely small shear gap generate very high shear forces. The rotor and stator are multi-stage and the individual stages vary in angle and slot geometry to achieve optimal processing of the product.

The stator can be infinitely adjusted to obtain the desired grinding gap setting.

Depending on the size of the machine, adjustment is via two manual levers on the housing or a hand crank. Optionally, the colloid mill can also be designed with a fixed, preset grinding gap. The colloid mill offers advantages in terms of energy efficiency, especially for higher-viscosity products with near-Newtonian viscosity behavior.

Example applications

- > Emulsions
- > Colloidal solutions
- > Micro-suspensions
- > Metal-oxide suspensions
- > Microencapsulation
- > Coating masses
- > Mustard
- > Ointments



Sizes MK 2000	Motor power [kW]	Flow rate* max. [l/h]	Motor speed [rpm]	Circumferential speed [m/s]
MK 2000/03 (magic LAB)	0.9	200	3,000	23
MK 2000/04 (Process Pilot)	1.5	300	3,000	23
MK 2000/05	7.5	2,500	3,000	23
MK 2000/10	15	7,500	3,000	23
MK 2000/20	37	20,000	3,000	23
MK 2000/30	55	40,000	1,500	23
MK 2000/50	160	60,000	1,500	23

* Self pumping rate with H₂O, 0.1 mm shear gap and standard tool

Cone mill MKO

/// Intensive shear to achieve the very smallest particles

Another unique IKA innovation, the cone mill MKO 2000 was designed to extend beyond the capabilities of the colloid mill. With its innovative design, it is capable of wet milling and grinding, producing even smaller particle sizes than a colloid mill. The milling gap is infinitely adjustable so that milling can be precisely controlled.

The surface of the milling tool is coated with an extremely hard coating that has a very rough surface texture. The coatings consist of high quality materials such as carbides and ceramics, and have different grain sizes. The machine generates an extremely intense shear zone that can process materials with high or low viscosities, but with even finer distribution and particle sizes than the colloid mill.

Example applications

- > Pigments
- > Polymers
- > Coatings
- > Crystals, wet milling
- > Ceramic slurries



Sizes MKO 2000	Motor power [kW]	Flow rate* max. [l/h]	Motor speed [rpm]	Circumferential speed [m/s]
MKO 2000/03 (magic LAB)	0.9	25	3,000	23
MKO 2000/04 (Process Pilot)	1.5	100	3,000	23
MKO 2000/05	4	150	3,000	23
MKO 2000/10	15	500	3,000	23
MKO 2000/20	37	1,500	3,000	23
MKO 2000/30	55	3,000	1,500	23
MKO 2000/50	160	6,000	1,500	23

* Typical flow rates for medium viscosity products at 0.1 mm shear gap

Corundum Disk Mill MCD

/// Inline mill for wet grinding

Corundum disk mills are mainly used for wet grinding of food products such as nuts and seeds. The corundum disks are available in different grains and are adapted to the product depending on the initial particle size and target fineness. The axially displaceable stator is moved relative to the rotor to adjust the grinding gap and is another process parameter in addition to the rotation speed. Due to the high shear forces and the rough surfaces of the grinding discs, the product is finely milled between rotor and stator and then discharged through the outlet at the side of the milling chamber. A cooling jacket integrated into the grinding chamber ensures a constant process temperature and therefore consistent quality, even with sensitive products.

Example applications

Fine milling of:

- > Mustard
- > Chili
- > Spice pastes
- > Nuts
- > Almonds
- > Sesame
- > Cocoa
- > Soybeans
- > Fruits
- > Vegetables
- > Fish pastes
- > Hemp seeds
- > Oats
- > Chickpeas



Sizes MCD	Flow rate [kg/h]	Motor power [kW]
MCD 2000/03 (magic LAB)	1 – 20	0.9
MCD 2000/04 (Process Pilot)	5 – 100	2.2
MCD 2000/05	10 – 200	4
MCD 2000/10	25 – 500	7.5
MCD 2000/20	45 – 1,100	11
MCD 2000/30	125 – 2,500	37
MCD 2000/50	200 – 4,500	75

Advantages

- > Depending on the product, outlet is via a funnel with a feed screw or via a feed pump.
- > Cooling jacket integrated into the housing
- > Precise and reproducible grinding gap adjustment
- > Grinding disks with different grain sizes
- > Separate bearing for the drive shaft
- > Sealing systems suitable for dry running
- > Low installation height

Inline Disperser | DBI 2000

/// High performance mixing & dispersing machine

The high-shear mixing and dispersing machine DBI 2000 is designed for batch operation with a recirculating loop. It is directly flange-connected to the vessel bottom outlet with a large cross section and pumps the product back into the mixing vessel. Due to its wide inlet and the double stage design, it is suitable for processing materials with low and high viscosity. The DBI 2000 provides suction, pumping, dispersing and is self-cleaning in accordance with CIP conditions. This unique device combines high flow rates, uniform particle size reduction and effective homogenization. Solid and liquid additives are fed directly into the dispersion chamber, which prevents lump formation and promotes rapid processing. The DBI 2000 can also be integrated into an existing system or process to replace inefficient machinery.

Example applications

- > Sunscreen
- > Ointments
- > Mayonnaise, dressings
- > Creams
- > Lotions
- > Gels
- > Mascara
- > Lipstick
- > Sauces
- > Fruit fillings
- > Fine chemicals
- > Emulsions/suspensions



Sizes DBI	Motor power [kW]	Max. total flow rate dispersing/pumping [l/h]	Max. viscosity of final product [mPas]
DBI 2000/03 (magic LAB)	0.9	max. 1,500	10,000
DBI 2000/04 (Process Pilot)	4	2,000/6,000	100,000
DBI 2000/05	7.5	5,000/15,000	100,000
DBI 2000/10	22	20,000/40,000	100,000
DBI 2000/20	45	45,000/80,000	100,000

Advantages

- > Free selection: pumping only or additional high shear dispersing
- > Direct feeding of solid and liquid additives
- > Effective dispersing with interchangeable tools
- > No additional pumps required for circulation, CIP or discharge
- > The innovative design ensures shorter processing times and optimum dispersing quality

Solid-Liquid Mixer CMX

// Powder incorporation in recirculation

Incorporating powders into liquids, without lumps and without dust, is an important part of many processes. The CMX 2000 utilizes a specially designed rotor that creates extreme suction to draw in solids, while it pumps the liquid at the same time. The liquid can then be re-circulated until all powders are incorporated.

Additional dispersing can be accomplished by continually re-circulating without adding more powder. Dispersing can then be continued with closed powder inlet.

Depending on the product and powder characteristics, high solids concentrations can be achieved.

Example applications

- > Hydrocolloids
- > Alumina suspensions
- > Starch solutions
- > Calcium carbonate
- > Milk powder
- > Fumed silica
- > Carbopol
- All applications where large quantities of solids are incorporated into liquids

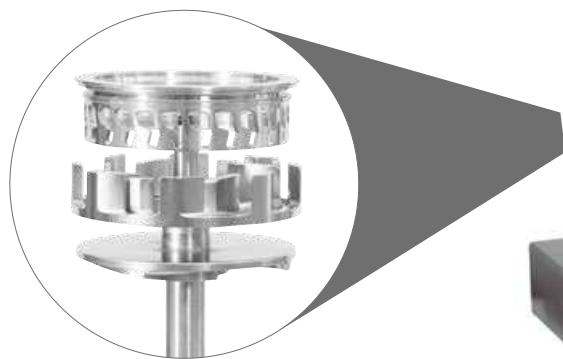

Sizes CMX	Motor power [kW]	Powder incorporation [kg/h]	Flow rate (max.) [l/h]
CMX 2000/03 (magic LAB)	0.9	250	1,500
CMX 2000/04 (Process Pilot)	4	1,300	5,000
CMX 2000/05	15	4,700	14,000
CMX 2000/10	30	8,900	32,000
CMX 2000/20	55	16,200	70,000
CMX 2000/30	110	25,500	110,000
CMX 2000/50	200	46,000	200,000

High performance mixing machine MHD 2000

/// Powder incorporation in a single pass

When production quantities require a non-stop process, the MHD is perfect for getting the job done. Solids and liquids are instantaneously mixed and dispersed in one step while maintaining a dust free environment. The MHD combines the solid and liquid, and disperses them into a homogeneous, final product. Tanks and other auxiliary equipment are usually unnecessary, saving on overall and operating costs. The MHD has a unique, patented design that doesn't require suction to draw in the powders, which eliminates aeration. The MHD offers the greatest flexibility in production, and maximum product consistency. The MHD can also run in recirculation mode for enrichment processes. The MHD prevents bridging and air entrapment. Scalability is ensured by maintaining a constant tip speed of 23 m/s throughout the product range.

Example applications

- > Fertilizers
- > Vitamins
- > Incorporation of color pigments
- > Pectines
- > Guar gum
- > Starches
- > Cellulose
- > Flour
- > Fillers



Sizes MHD	Motor power [kW]	Flow rate (max.) [l/h]	Max. solids capacity [l/h]
MHD 2000/03 (magic LAB)	0.9	50	30
MHD 2000/04 (Process Pilot)	2.2	200	100
MHD 2000/05	5.5	700	500
MHD 2000/10	11	2,500	1,300
MHD 2000/20	15	7,000	2,800
MHD 2000/30	30	20,000	6,200
MHD 2000/50	75	40,000	11,200

Batch dispersing

/// Rotor-stator technology for maximum performance

IKA is the world leader in the design and production of high-performance mixers and process plants. IKA produces a complete line of mixers for laboratories and industrial production. Our high-performance mixers and dispersers feature our proven rotor-stator designs that are used in thousands of chemical, food, pharmaceutical and cosmetic companies.

These machines are designed to meet the highest requirements and offer maximum flexibility in use on site.

Rotor-Stator System

/// The best in dispersing technology

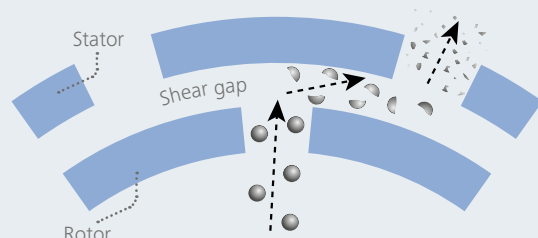

UTS, UTC and UTE batch dispersers

/// Dispersing/stirring in a batch process

The ULTRA-TURRAX machines are frequently used to produce emulsions, solutions and suspensions. A variety of interchangeable generators (rotor + stator) allow for perfect adaptation to the applicable mixing task. There are also different seal variants, suitable for an operating pressure of up to 10 bar and temperatures of up to 160 °C. The UTC and UTS are also designed for top mounting (vessel cover or stand). The UTC has a closed, sealed shaft, while the UTS has an open design without a seal in the product area. The shaft is reliably guided via a ceramic support bearing. The UTE model is designed for installation in the bottom of the vessel. It has the advantage that the stirrer can still be used even if the fill level in the vessel is very low. The design also impresses thanks to its robustness and compact design without a long shaft.

Advantages

- > Various shaft seal types
- > Surfaces according to pharmaceutical requirements available as an option
- > Generators of different designs suitable for your application

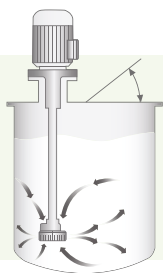

ULTRA-TURRAX UTC-KT
(ambient)

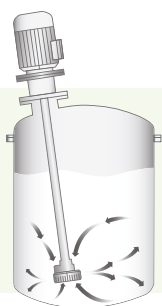

ULTRA-TURRAX UTC-KD
(vacuum/pressure)

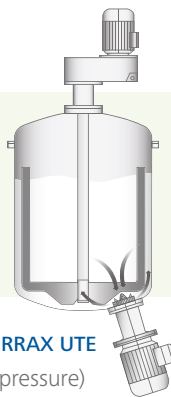

ULTRA-TURRAX UTE
(vacuum/pressure)



Sealing type KD (mechanical seal)

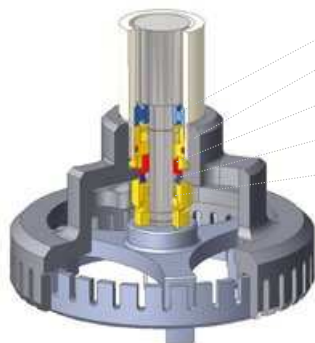

- Ball bearing
- O-ring
- Counter ring
- Sliding ring
- Pressure spring

Sealing type KT (lip seal)

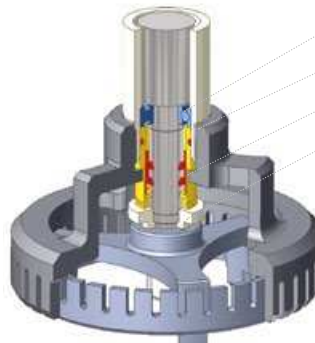

- Ball bearing
- O-ring
- 2 radial shaft seals
- Centrifugal ring

ULTRA-TURRAX UTC/UTS

/// High-performance dispersing machines

Example applications

- > Emulsions
- > Suspensions
- > Solutions
- > Incorporation of thickeners
- > Paints and lacquers
- > Lotions

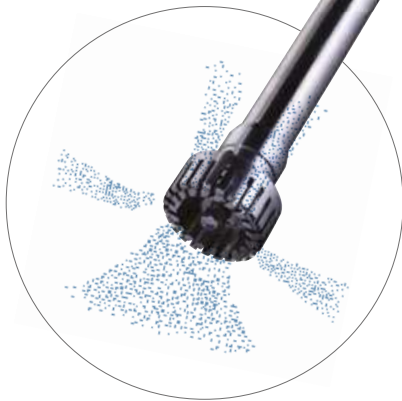

Sizes UTS/UTC	Batch size* [l]	Rotational speed [rpm]	Circumferential speed** [m/s]	Motor power [kW]
UTC 80	30- 150	3,000	10	1.5
UTC/UTS 115	100- 500	3,000	15	3
UTC/UTS 150	350 - 1,700	3,000	21	7.5
UTC 220	500 - 2,500	1,500	15	11
UTC/UTS 280	750 - 3,500	1,500	20	18.5
UTC 300	800 - 4,000	1,500	21	30
UTC 330	1,000 - 5,000	1,000	15	22
UTC 350	1,200 - 6,000	1,000	17	32

* Depending on the product viscosity. Regular range 1 – 5,000 mPas.
 ** Higher circumferential speeds can be achieved as an option with frequency converter on all UTC and UTS models.

ULTRA-TURRAX UTE

/// High-shear batch mixer for bottom installation

By being installed from below, the ULTRA-TURRAX UTE delivers optimal dispersion even at relatively low vessel levels (small quantities). The robust design without a shaft tube and with a long shaft is also suitable for crushing larger lumps or polymer blocks and is easy to clean. The machine is available in versions for working in a vacuum up to pressures of 16 bar at temperatures up to 160 °C.

Example applications

- > Emulsions
- > Suspensions
- > Solutions
- > Printing dyes
- > Polymer solutions (VI improvers)
- > Eye drops
- > Crushing larger lumps or blocks



Sizes UTE	Batch size* [l]	Circumferential speed** [m/s]	Motor power [kW]
UTE 60	20- 70	23	1.85
UTE 115	80- 400	15	2.5
UTE 150	150- 750	21	5.5
UTE 220	250 - 1,200	15	11
UTE 280	500 - 2,500	20	22
UTE 300	800 - 4,000	21	30
UTE 350	2,000 - 8,000	26	55
UTE 400	5,000 - 15,000	27	132
UTE 450	10,000 - 25,000	30	160
UTE 600	15,000 - 35,000	29	250

Advantages

- > Prevents aeration
- > Capable of operating under pressures of up to 16 bar
- > CIP and SIP capable
- > Limited surfaces in contact with product (no shaft tube)
- > Machine can run at very low liquid levels
- > Easy to clean
- > No bearings in area in contact with product
- > Very robust design

* Depending on the product viscosity. Regular range 1 – 5,000 mPas.

Batch mixing/stirring

/// Overview of the different stirrers



Anchor stirrer



Propeller stirrer



Disk stirrer



Turbine stirrer



Toothed disk stirrer

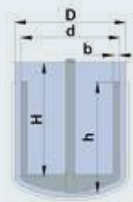

$$0.75 \leq \frac{D}{H} \leq 1$$

$$0.9 \leq \frac{d}{D} \leq 0.98$$

$$0.75 \leq \frac{h}{d} \leq 1$$

$$b \approx 0.1 \cdot d$$

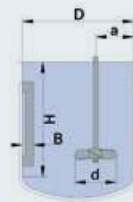

$$0.5 \leq \frac{D}{H} \leq 0.75$$

$$0.1 \leq \frac{d}{D} \leq 0.5$$

$$\frac{D}{3} \leq a \leq \frac{D}{2}$$

$$B \approx 0.1 \cdot D$$

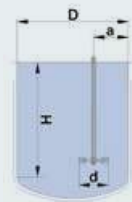

$$0.5 \leq \frac{D}{H} \leq 0.75$$

$$0.2 \leq \frac{d}{D} \leq 0.5$$

$$\frac{D}{3} \leq a \leq \frac{D}{2}$$

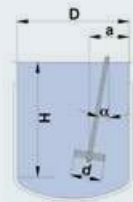

$$0.5 \leq \frac{D}{H} \leq 0.75$$

$$0.1 \leq \frac{d}{D} \leq 0.3$$

$$\frac{D}{3} \leq a \leq \frac{D}{2}$$

$$\alpha = 10^\circ$$

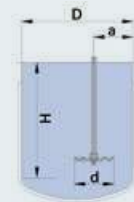

$$0.2 \leq \frac{d}{D} \leq 0.5$$

$$\frac{D}{3} \leq a \leq \frac{D}{2}$$

$$0.75 \leq \frac{D}{H} \leq 1$$

	Anchor stirrer	Propeller stirrer	Disk stirrer	Turbine stirrer	Toothed disk stirrer
Circumferential speed [m/s]	0.5 – 1.5	3 – 10	3 – 7	2 – 12	10 – 25
Max. viscosity range [mPas]	50,000	5,000	10,000	8,000	50,000



ROTOTRON RTS

/// Jet flow agitator for flexible installation

The IKA ROTOTRON RTS jet flow agitator is a universal overhead stirrer. RTS-type machines are used for homogenizing, dispersing, suspending, emulsifying, de-aeration and dissolving. The highly-efficient jet flow agitator delivers high circulation and mixing effect with low energy consumption.

The ROTOTRON RTS is suitable for eccentric top entry and from the side into vessels below the fill line. For many applications, it replaces the use of conventional agitators with long shafts.

The IKA ROTOTRON RTS can be used to process media up to a viscosity of 15,000 mPas.

Depending on application, the direction of rotation can be changed. To prevent sedimentation and floating ingredients, the flow direction is downwards. To process higher viscosities and to avoid aeration, you can change the direction of rotation and therefore the direction of flow.

Example applications

- > Food industry:
ice cream, chocolate, flavorings, drinks
- > Paint and dyes: inks, watercolors
- > Paper industry: adhesives, pulp
- > Chemical industry: dyes, fertilizers, pesticides



Optional design

Sizes RTS	Batch size max. (H ₂ O) [l]	Rotational speed [rpm]	Motor power [kW]
RTS 115	1,000	3,000	2.2
RTS 150	5,000	3,000	3
RTS 220	10,000	1,500	7.5
RTS 280	20,000	1,500	22
RTS 350	30,000	1,000	30

Advantages

- > Rapid mixing and dispersing results
- > Completely homogeneous mixing of the product in all areas of the vessel, even for critical vessel geometries
- > Energy efficient
- > No rotation of the mixture; flow breakers are not required
- > Whirlpool effects and aeration are prevented
- > Flexible installation options in vessels with a wide variety of sizes
- > No seals in the processed product
- > Interchangeable mixing heads

TURBOTRON RK/RF

/// The classic agitator



The IKA TURBOTRON is our classic agitator. Different drives, stirring tools and sealing variants allow optimal adaptation to your application.

The RK and RF type agitators do not require a gear and can be used for viscosities of up to approx. 1,000 mPas. The IKA TURBOTRON RK is designed for unpressurized applications. The bearing flange is optimized for attachment to a stand or mounting plate.

The TURBOTRON RF can also work under vacuum or pressure within a wide temperature range. On the standard version, sealing is via a shaft sealing ring made of PTFE compound (2.5 bar). Alternatively, double-acting mechanical seals for pressures of up to 10 bar are also available. The RF is designed to be attached to a vessel flange. The machine size and the stirring tool can be selected to suit your application and the installation length can be adapted to your vessel.



Sizes RK/RF	Batch size max. (H ₂ O) [l]	Rotational speed [rpm]	Motor power [kW]	Installation length [mm]
RK/RF 00	500/1,000	1,000/1,500	0.37/0.55	800/1,500
RK/RF 01	1,000/2,000	1,500	0.55/0.75	1,000/1,500
RK/RF 02	1,500/3,000	1,000	0.75/1.5	1,000/1,750
RK/RF 03	2,000/4,000	1,000	1.1/2.2	1,250/1,500
RK/RF 04	2,500/5,000	750	1.5/3	1,500/1,500
RK/RF 05	3,000/6,000	750	2.2/4	1,750/1,750
RK/RF 06	3,500/8,000	1,000	3/5.5	1,750/1,750
RK/RF 07	4,000/12,000	1,000	4/7.4	1,750/2,000

Advantages

- > Different drives are available: for low or variable speeds
- > Machines are suitable for ambient pressure (RK) and pressure vessels (RF)
- > Optional frequency converters enable infinite speed adjustment
- > All wetted parts are stainless steel
- > Suitable for use in the food industry and pharmaceutical sector

TURBOTRON RKG/RFG

/// The best choice for high viscosities

The RKG and RFG agitators have a drive with a reduction gear and are also suitable for higher viscosities or stirring tools with larger diameters thanks to their slower speeds. The IKA TURBOTRON RKG is designed for unpressurized applications. The bearing flange is optimized for attachment to a stand or mounting plate. The IKA TURBOTRON RFG can also work under vacuum or pressure within a wide temperature range. On the standard version, sealing is via a shaft sealing ring made of PTFE compound (2.5 bar). Alternatively, double-acting mechanical seals for pressures of up to 10 bar are also available. In this case as well, the machine size and the stirring tool can be selected to suit your application and the installation length can be adapted to your vessel.



Sizes RKG/RFG	Batch size max. (H ₂ O) [l]	Rotational speed [rpm]	Motor power [kW]	Installation length [mm]
RKG/RFG 00	1,000	250	0.55	1,250/1,500
RKG/RFG 01	1,500	250	0.75	1,250/1,500
RKG/RFG 02	3,000	250	1.5	1,500/1,500
RKG/RFG 03	4,000/6,000	250	2.2/3	1,500/1,750
RKG/RFG 04	5,000/8,000	250	3/4	1,750/2,000
RKG/RFG 05	6,000/12,000	250	4/5.5	2,000/2,500
RKG/RFG 06	8,000/15,000	250	5.5/7.5	2,000/2,750
RKG/RFG 07	12,000/20,000	250	7.4/9.2	2,000/3,000

TURBOTRON RKG 00-Bo

/// The explosion-proof agitator

IKA-TURBOTRON RKG-00-Bo ATEX machines are high-performance, mechanical agitators with explosion protection for laboratories, pilot plants and small-scale production. They are designed for use in open or unpressurized vessels for processing flowing mixtures in the low and medium viscosity range. They can be easily fitted with a propeller, turbine, dissolver, centrifugal, flat or anchor stirrer using a mounting chuck.

The speed can be adjusted in a very wide range from 20 to 1,200 rpm.

The RKG-00-Bo ATEX machines are an explosion-proof alternative to the IKA RW 28 digital and RW 47 digital laboratory and pilot plant machines. The IKA-TURBOTRON RKG-00-Bo agitators that are delivered to customers in the EU are approved for operation in Ex zone 1 (2G), temperature class T3 according to ATEX 95.



Sizes RKG 00-Bo	Batch size max. [l]	Speed min. [rpm]	Speed max. [rpm]	Motor power [kW]
RKG 00-Bo 0.25 kW ATEX	80	20	1,200	0.25
RKG 00-Bo 0.55 kW ATEX	200	20	1,200	0.55
RKG 00-Bo 0.75 kW ATEX	275	20	1,200	0.75



Stands

/// The practical addition to your agitator

Many different stands are available for all IKA agitators and ULTRA-TURRAX batch machines. Raising and lowering is done with a manual hydraulic pump or alternatively automatically with an electric pump. The stands are available in mobile designs, for mounting on the floor or on the wall.

The maximum lifting height of the stands can be configured to suit the application, if necessary. Vessel clamping devices and versions made of stainless steel with high-quality surfaces for the food, pharmaceutical and cosmetics industries are also optionally available.



Stands

/// Overview



SFH 150

Mobile stand with hydraulic hand pump



SFH 150 stainless steel

A mobile stand in stainless steel with hydraulic hand pump, control panel and vessel clamping device

SBAE 150

Stand for floor mounting with automatic height adjustment



SWAE 150

Stand for wall mounting with automatic height adjustment

Sizes Stands	Type of stand	Max. load [kg]	Max. lift [mm]	Lift
SFH 150/SFH 250	Mobile stand	100/200	1,000	Manual
SFAE 150/SFAE 250		100/250	1,000	Automatic
SBH 150/SBH 250	Floor stand	100/250	1,200	Automatic
SBAE 150/SBAE 250		100/250	1,200	Automatic
SWH 150/SWH 250	Wall stand	100/250	1,600	Automatic
SWAE 150/SWAE 250		100/250	1,600	Automatic

Systems & plants

/// Always right for your process

IKA processing plants can be used to produce solutions, emulsions and suspensions in many applications. Owing to the advanced design, they can handle products that range from low to high viscosity.

Our plants are flexible and easily adaptable to any application. They are used, for example, to produce cosmetic creams and lotions in the cosmetics and pharmaceuticals industry, mayonnaise and dressings in the food industry, suspensions and emulsions in the chemical industry, and for paints and lacquers. Based on our long experience with many applications, IKA is your expert partner for process plants.



Scale-up

/// Develop – Optimize – Scale from lab to production

Simplified scale-up using identical dispersing parameters for all sizes makes for reliable scaling up. When new products are developed, the processes are initially tested in pilot plants. Lab-scale trials are also used to confirm changes in recipes or ingredients.

By using identical design and dispersion parameters, IKA systems guarantee reliable scale-up with constant product quality.



Systems & plants

/// Overview



IKA magic LAB

The tiny, yet powerful inline laboratory dispersing machine, designed for mixing dispersing and wet milling. It can also be converted for batch operation with a 1 to 2 liter capacity.



IKA magic PLANT

The most versatile laboratory reactor with a 2-liter vessel and an agitator for mixing and homogenizing liquids and pastes.



Compact Mixing Plant XPP

The compact mixing and dispersing plant XPP has that something extra for your process technology. It is ideally suited to homogeneously incorporating large quantities of powdered solids and liquid additives into a liquid, efficiently and cost-effectively.

Standard Production Plant

The tried-and-tested and cost-effective Standard Production Plant (SPP) is the IKA solution for many applications. It is available in 8 sizes with capacities ranging from 25 to 4,000 liters.



Master Plant

IKA's homogenizing and emulsifying Master Plant is available for useful volumes from 10 to 4,000 liters. It mixes and disperses efficiently, controls the temperature and feeds additives. The innovative GMP-compliant mixing plant is ideal for processing high viscosity products, especially in the food, cosmetic and pharmaceutical industries.



IKA pilot plants

/// Magic LAB



IKA magic LAB 2000/03

The unique and versatile laboratory machine for new product development and product and process optimization. The seven interchangeable mixing modules make it the ideal machine for continuous, recirculation and batch processes. Standard version with ULTRA-TURRAX UTL module



IKA magic LAB XP

The magic LAB XP is an upgraded version of the magic LAB. It was developed for applications with one or more of the following requirements:

- > High pressure/high vacuum
- > High power requirements
- > Processing of abrasive products
- > Optional explosion-proof design

Technical data	magic LAB 2000/03	magic LAB XP
Power supply [V]	1-phase, 220 – 240	3-phase, 380 – 420
Motor power [kW]	0.9	3
Max. product temperature in continuous/intermittent operation [°C]	80/120	120
Max. process vacuum/pressure [bar]	-0.5/2.5	-1/7
Nominal speed [rpm]	14,600	14,600 (approx. 57 Hz)
Adjustable rotational speed range [rpm]	3,000 – 26,000*	See CONTROLLER
Circumferential speed** [m/s]	23	23
Flow rate** [l/h]	100	100
Dimensions of basic machine (W x D x H) [mm]	170 x 270 x 215	450 x 250 x 930
Weight of basic machine [kg]	7	48
Dimensions of transport box (W x D x H) [mm]	350 x 460 x 560	–
Weight of basic machine in transport box [kg]	20	–

* Including controller** At 14,600 rpm, UTL module, 4 M, water

IKA pilots give you the following options:

- > Choose the process technology to be used
- > Define the required machine and plant size
- > Establish the necessary power requirements
- > Determine the required quality and volume of the raw materials
- > Calculate and define the quality standard of the final product
- > Determine the flow rate and loading times of the production system

Technical data	magic LAB XP CONTROLLER
Max. motor power [kW]	3
Frequency range [Hz]	20 – 95
Speed range [rpm]	5,000 – 23,500
Circumferential speed [m/s]	7.8 – 37

IKA pilot plants

/// Lab Pilot and Process Pilot



IKA Lab Pilot 2000/04

Inline pilot scale dispersing machine with ability to upscale to production scale. Standard version with ULTRA-TURRAX UTL module with single seal.



IKA Process Pilot 2000/04

Pilot scale inline dispersing machine with mechanical seal. Suitable for working under vacuum/pressure and at high temperatures. Standard version with ULTRA-TURRAX UTL module.



ULTRA-TURRAX UTL module

Single stage module for producing simple emulsions & suspensions.



DISPAX REACTOR DR module

Three stage disperser for producing the finest emulsions and suspensions and for simulating single pass processes.



**Colloid Module/
Cone Mill MK/MKO**

Wet milling using a milling tool with an adjustable gap Emulsifying (MK) and de-agglomeration (MKO) of viscous products.

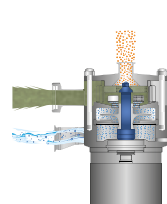

CMX module

Lump free and dust free incorporation of powders and granules into liquids.



MHD module

Continuous incorporation of powders into liquids, quantity based & in 1 process step.



DBI module

2-stage module for pumping, dispersing & sucking in liquids and solids in combination with a recirculation loop and a mixing vessel.

Technical data	LAB PILOT 2000/04	PROCESS PILOT 2000/04
Power supply [V]	3-phase 380 – 420	3-phase 380 – 420
Motor power [kW]	1.5/2.2	2.2/4
Max. product temperature [°C]	120	120
Max. process pressure/vacuum [bar]	3/-0.5	10/-1
Speed [rpm]	8,050	8,050
Circumferential speed [m/s]	23	23
Flow rate [l/h]*	500	500
Dimensions (W x D x H) [mm]	450 x 250 x 350	450 x 250 x 900
Weight of basic machine [kg]	36	53

* At 8,050 rpm, UTL module, 4 M, water

Technical data	LAB PILOT CONTROLLER	PROCESS PILOT CONTROLLER
Max. motor power [kW]	2.2	4
Frequency range [Hz]	20 – 87	20 – 87
Speed range [rpm]	3,170 – 13,789	3,170 – 13,789
Circumferential speed [m/s]	9.4 – 41	9.4 – 41

magic PLANT

/// Exceptional - Flexible - Unique

IKA introduces the next generation of laboratory-scale process plants. The perfect simulation of our batch mixing systems with smallest batch volumes. The magic PLANT is the ideal laboratory scale process plant. It is specifically designed to test process and product conditions in an accurate small-scale simulation.

Once a satisfactory product is obtained at pilot scale, the next step is to upscale the manufacturing process to full scale production. The magic PLANT system can be adapted to a wide range of applications and specific requirements, especially in the food, cosmetic, chemical and pharmaceutical industries.

Our magic PLANT is used for batch mixing, homogenizing, emulsifying, suspending, powder mixing and drying. The magic PLANT delivers seamless process upscaling from product development to production at capacities of up to 2 liters.



Advantages

- > Modular design with interchangeable tools
- > Process simulation with the smallest quantities
- > Suitable for wet and dry products

Technical data	magic PLANT
Useful volume [l]	2
Operating pressure [bar]	-1 up to 2.5 (optionally 5 bar)*
Max. temperature [°C]	120/150
Dimensions (W x D x H) [mm]	430 x 520 x 670
Voltage [V]	1 x 230
Viscosity [mPas]**	1 – 100,000

* for magic PLANT basic and powder

** depending on design and product properties.

Technical data	Agitator
Speed [rpm]	0 – 2,000 (propeller) 0 - 350 (anchor and spiral stirrers)
Stirring tools	> anchor > propeller > spiral agitator for drying > flow breaker
Motor power [W]	400

Technical data	Disperser T 25 (optional)
Motor power [W]	500
Speed [rpm]	3,400 – 24,000

magic PLANT

/// Exceptional - Flexible - Unique

The IKA magic PLANT is an extremely versatile and multi-functional process plant. Depending on application, it can easily be modified into three different configurations.



magic PLANT basic

- > Adjustable drive for perfect stirring of liquids and suspensions
- > Tilting, double walled and insulated vessel
- > Interchangeable stirring tools
- > Optional ULTRA-TURRAX T 25 batch disperser
- > Operates with pressure and vacuum

magic PLANT in-line

- > In combination with the magic LAB dispersing machine for high quality emulsions and solutions
- > Recirculation loop with 3-way valve for circulation or discharge of the product
- > Modular dispersing chamber to simulate different dispersing methods
- > Adjustable circumferential speed up to 40 m/s for the smallest particle sizes

magic PLANT powder

- > Efficient and product-friendly mixing of free-flowing substances
- > Special powder agitator
- > Better mixing and drying results by tilting the complete mixing system
- > Complete emptying of the vessel by tilting
- > Double walled cover for heating to avoid condensation

Standard Production Plant SPP

/// Cost-efficient mixing plant

With its tried-and-tested Standard Production Plant (SPP), IKA provides a solution for producing emulsions and suspensions in many different applications. It is available in 8 sizes with useful volumes from 25 to 4,000 liters.

The SPP is a cost-effective mixing plant for all standard processes such as mixing, stirring, homogenizing and dispersing. Owing to its unique geometry, the plant is easy to operate and requires little space, especially height.

Cutting-edge mixing tools ensure consistent product quality.

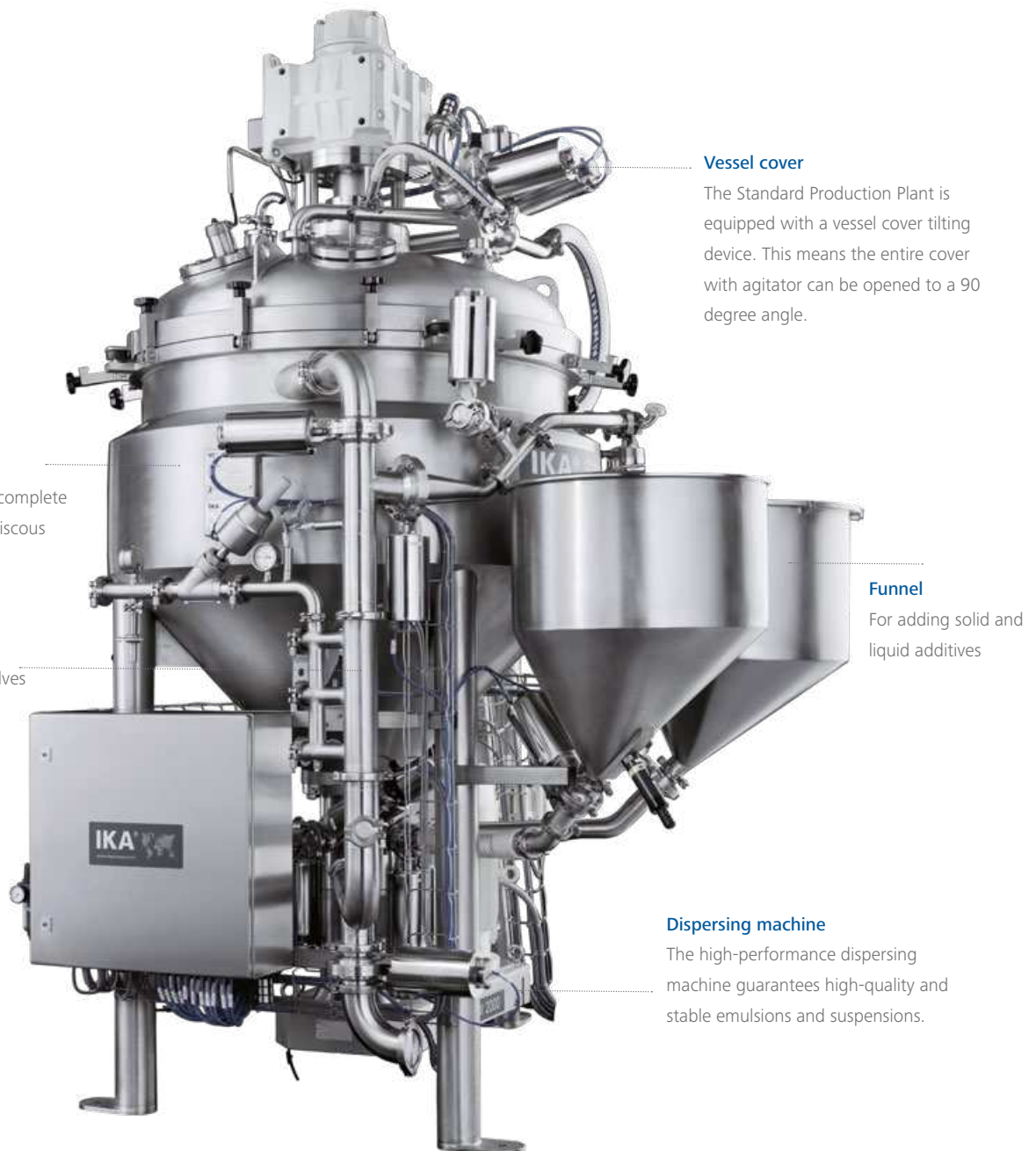

Vessel cover

The Standard Production Plant is equipped with a vessel cover tilting device. This means the entire cover with agitator can be opened to a 90 degree angle.

Mixing vessel

The unique conical shape of the vessel bottom enables complete discharge — even for highly viscous products.

Recirculation loop

Large pipe with 2-way flap valves and clamp connections

Funnel

For adding solid and liquid additives

Dispersing machine

The high-performance dispersing machine guarantees high-quality and stable emulsions and suspensions.



Example applications

- > Cosmetic creams and lotions
- > Mayonnaise, dressings
- > Paints and lacquers
- > Fruit juices
- > Collagen suspensions
- > Disinfectants
- > Lipid emulsions
- > Ceramic suspensions

Further advantages of the SPP:

- > Special versions available for the food and pharmaceutical industries
- > Extremely short batch times with high product quality
- > CIP and SIP capable
- > Infinitely variable speed control possible
- > Explosion-proof version available as an option
- > Low minimum quantities of approx. 30% of the maximum capacity
- > Low installation height
- > Flexible configuration, e.g. with differently installed in-line dispersers, single- or multi-stage



SPP TECHNICAL DATA	SPP 25	SPP 50	SPP 100	SPP 250	SPP 500	SPP 1000	SPP 2000	SPP 4000
Total connected load [kW]	5	6	9	10	25	28	55	60
Mixing vessel								
Min. useful volume [l]	8	15	30	75	150	300	600	1,200
Max. useful volume [l]	25	50	100	250	500	1,000	2,000	4,000
Dimensions								
Height (closed cover) [mm]	1,350	1,497	1,720	2,031	2,789	3,156	3,725	4,449
Height (open cover) [mm]	1,539	1,695	2,004	2,486	3,279	3,819	4,610	5,690
Width [mm]	1,182	1,221	1,370	1,817	2,573	2,935	3,923	5,072
Depth [mm]	828	860	1,080	1,250	1,350	1,981	2,278	2,862

Master Plant MP

/// Universal mixing plant

The Master Plant homogenizing and emulsifying system is a universal mixing system. It is ideally suited to efficiently mixing, dispersing, tempering and optimally incorporating additives. The innovative GMP compliant mixing plant enables processing of high viscosity products, even under pressure and vacuum. It also guarantees the highest level of precision, reliability and reproducibility of results.



Connections

For vacuum, compressed air or funnel (additives)

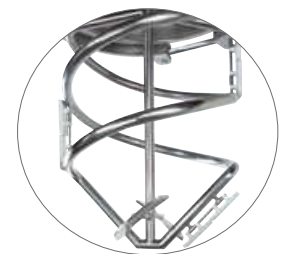

Alternative

Spiral stirrer can be heated/cooled
Counter-rotating stirrer with
movable scrapers and a heatable
or coolable inner stirrer

Human machine interaction

With touchscreen monitor

Funnel

For incorporation of solids and liquids

Recirculation line

System Design

Completely encased in stainless steel



Dispersing machine

The high performance dispersing machine DBI ensures high quality, stable emulsions and suspensions.



Example applications

- > Decorative cosmetics
- > Ready meals, baby food
- > Jams
- > Ointments, gels
- > Vaccines
- > Cleaning & polishing agents
- > Polymer emulsions
- > Impregnating agents

Further advantages of the MP:

- > Special versions available for the food and pharmaceutical industries
- > Feed solid and liquid additives into the dispersing chamber
- > CIP and SIP capable
- > Infinitely variable speed control possible
- > Explosion-proof version available as an option
- > Separate recirculation loop (short/long) to minimize dead space and loss of material
- > Interchangeable dispersing tools
- > Low maintenance requirements
- > Optional counter-rotating stirrer for highest viscosities; inner stirrer can be heated/cooled



MP TECHNICAL DATA	MP 10	MP 25	MP 50	MP 100	MP 200	MP 500	MP 1000	MP 2000	MP 4000
Total connected load [kW]	5	7	8	12	13	31	35	70	80
Mixing vessel [l]	13	32	65	130	260	650	1,350	2,600	5,200
Min. useful volume [l]	1.5	3.8	7.5	15	30	75	150	300	600
Max. useful volume [l]	10	25	50	100	200	500	1,000	2,000	4,000
Working pressure in the vessel [bar]	-1 to 2.5	-1 to 2.5	-1 to 2.5	-1 to 2.5	-1 to 2.5	-1 to 2.5	-1 to 2.5	-1 to 2.5	-1 to 2.5
Max. temperature in the vessel [°C]	150	150	150	150	150	150	150	150	150
Dimensions									
Height (closed cover) [mm]	1,230	1,637	1,817	2,243	2,447	3,315	3,790	4,951	5,488
Height (open cover) [mm]	1,680	2,150	2,417	2,998	3,377	4,615	5,379	7,051	7,858
Width [mm]	630	850	850	1,215	1,215	1,650	1,650	2,210	2,210
Depth [mm]	656	1,010	1,130	1,405	1,405	1,900	1,900	2,710	3,060

Conical Dryer CD

/// Tilting for the perfect drying result

Efficient and at the same time gentle mixing of free flowing solids with different bulk densities and particle sizes is what you get with the Conical Dryer CD. It ensures uniform moisture and temperature distribution throughout the product chamber. The Conical Dryer CD uses gentle mixing for drying, combined with uniform heating of the moist raw materials via the vessel wall, the stirrer and the cover. Your bulk material is effectively dried at temperatures up to 200 °C and under vacuum.





Example applications

- > Metal oxides
- > Coffee powder products
- > Soup powder
- > Sauces
- > Baby food
- > Active pharmaceutical ingredients

Further advantages of the Conical Dryer CD

- > Shorter drying times thanks to the directly heated spiral stirrer and the double walled, heatable vessel and vessel cover
- > Flow breaker with integrated temperature sensor PT 100
- > Floating lump breaker for breaking up any agglomerates
- > Compact, low profile design
- > Optional ATEX/GMP design



Technical data Conical Dryer	Min. useful volume [l]	Max. useful volume [l]	Feed nozzle [size]	Outlet valve	Motor power [kW]	Directly heater stirrer	Speed range [rpm]
magic PLANT powder	0.5	2	1"	DN 25	0.4	-	0 - 350
CD 10	3	10	2"	DN 65	0.37	+	30 - 112
CD 25	7.5	25	3"	DN 65	0.75	+	22 - 83
CD 50	15	50	3"	DN 100	1.5	+	18 - 68
CD 100	30	100	4"	DN 100	3	+	14 - 54
CD 250	75	250	4"	DN 150	5.5	+	11 - 41
CD 500	150	500	6"	DN 150	11	+	8 - 32
CD 1,000	300	1,000	6"	DN 150	18.5	+	7 - 26
CD 2,000	600	2,000	8"	DN 200	30	+	6 - 21
CD 4,000	1,200	4,000	8"	DN 200	37	+	5 - 18
CD 7,000	2,100	7,000	8"	DN 200	45	+	5 - 18
CD 10,000	3,000	10,000	8"	DN 250	90	+	4.4 - 16.5

Compact Mixing Plant XPP

/// Excellent end products, even for viscous products with a high proportion of solids

The compact mixing and dispersing plant XPP was designed to produce special products with a particularly high solid content, with short batch times too. Large quantities of powdered solids and liquid additives are efficiently and homogeneously incorporated into a liquid. This extreme mixing and dispersing performance is achieved by the CMX inline mixing machine integrated into the floor of the plant. Compact in design, the easy-to-use XPP is your ideal process plant.





Example applications

- > Interior paint
- > Hydrocolloids/thickeners
- > Electrode coatings
- > Sunscreen
- > Adhesives
- > Disinfectants
- > Pigment dispersion
- > Fruit fillings
- > Sealants
- > Lacquers

Further advantages of the XPP

- > Excellent dispersing performance, even with highly viscous mixtures up to approx. 10,000 mPas
- > Customized designs such as ATEX, automatic valves, dosing systems for product components and special stirrer designs
- > Practical accessories such as different solids feed systems (sack chutes, suction lances, big bag stations) and optional extensions such as additional vessels
- > CMX as an integrated CIP and discharge pump
- > Double jacketed vessel for temperature control, as well as pressure/vacuum version e.g. for degassing integrated as standard



XPP TECHNICAL DATA	XPP 50	XPP 100	XPP 200	XPP 500	XPP 1000	XPP 2000	XPP 4000
Min. useful volume [l]	15	25	40	100	200	400	800
Max. useful volume [l]	50	100	200	500	1,000	2,000	4,000
Temperature range [°C]	-10/+150	-10/+150	-10/+150	-10/+150	-10/+150	-10/+150	-10/+150
Vacuum/pressure [bar g]	-1/+2.5	-1/+2.5	-1/+2.5	-1/+2.5	-1/+2.5	-1/+2.5	-1/+2.5
Viscosity in Newtons [mPas]	1 – 5,000	1 – 10,000	1 – 10,000	1 – 10,000	1 – 10,000	1 – 10,000	1 – 10,000
Viscosity shear thinning [mPas]	max. 50,000	max. 100,000	max. 100,000	max. 100,000	max. 100,000	max. 100,000	max. 100,000
Stirrer [type]	Anchor	Anchor	Anchor	Anchor	Anchor	Anchor	Anchor
Motor power of stirrer [kW]	0.55	0.75	1.1	1.5	3	4	7.5
Dimensions [mm]							
Length x Width	1,200 x 850	1,450 x 950	1,580 x 1,100	1,900 x 1,400	2,300 x 1,810	3,100 x 2,600	3,500 x 3,000
Height (closed cover)	1,350	1,650	1,810	2,450	2,900	3,600	4,200
Height (open cover) [mm]	1,600	2,000	2,206	2,900	3,500	4,500	5,500
Weight [kg]	500	980	1,200	2,150	3,800	5,400	9,600

You can find further details in our product brochures or at www.ikaprocess.com

Vacuum drying & mixing



Dilution plants

For highly efficient and economical production



IKA laboratory & analytical technology

IKA is the undisputed leader worldwide for laboratory technology. Numerous innovations are evidence of the growing momentum within the company.

Magnetic stirrers, agitators, dispersers, shakers, mills, rotary evaporators, calorimeters, temperature control instruments and laboratory reactors make up just a small part of the vast laboratory and analytical technology product range.



Dry milling

Impact and cutting mill for dry materials | Pilotina
Deagglomeration of solids | CONIKA



High pressure homogenizer

For applications with particle sizes in the nano range



Kneading

Vertical, horizontal and continuous kneading





Service

/// First-class quality from initial contact through to production

From the initial planning stages to final product, the IKA technology and service departments are with you each step of the way, offering a range of services:

- > Designing complete production plants
- > Performing test runs when developing new products
- > Planning and implementing mechanical, electrical and pneumatic installations
- > Commissioning, including test operation and training for operating personnel
- > Qualification

After project completion, our experienced engineers, electricians, process engineers and assemblers are available to assist you with:

- > Technical advice for questions about operation, process and maintenance of IKA machines and plants
- > Spare parts service
- > Repair service
- > Modification
- > Remote maintenance



Qualification

/// For the pharmaceutical sector

According to GMP specifications, pharmaceutical companies are required to validate processes that influence product quality. The machines and plant that are used undergo a tough qualification process. Qualification involves testing and documenting that the specified functionality is achieved. Right at the planning stage, IKA machines and plant are designed to be suitable for use in the pharmaceutical industry.

IKA can provide the necessary documentation and, if desired, can carry out the design, installation and operational qualification with you.

Test Center

/// From idea to solution

Looking for the ideal machine for your application?

The IKA Test Center gives you of a vast array of different machines and plants, as well as measuring and analytical devices. In close collaboration, we can manufacture your product on a small or large scale on IKA equipment, depending on your needs. Our process engineers look forward to advising you on trials and developing and testing the best production method together. So we can find the ideal solution for your specific mixing task.









designed to work perfectly

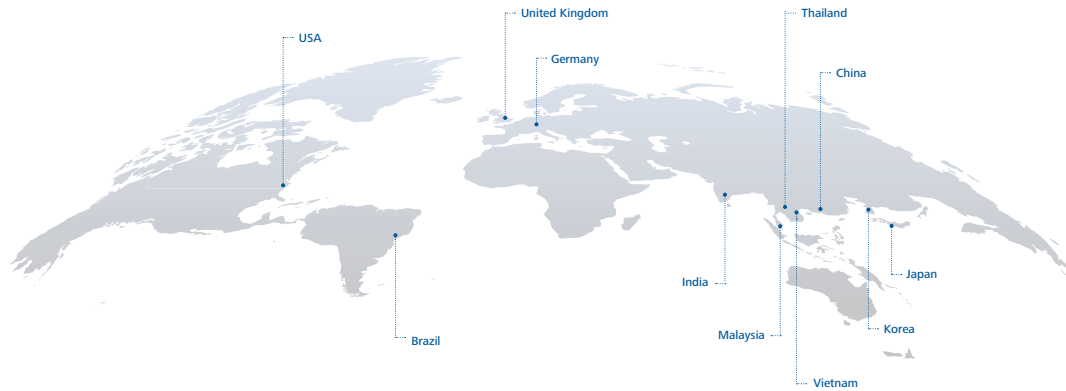

EN

IKA-Werke GmbH & Co. KG

Janke & Kunkel-Strasse 10, 79219 Staufen, Germany

Phone: +49 7633 831-0

Email: process@ika.de

/// WORLDWIDE

USA

IKA Works, Inc.

Phone: +1 910 452-7059

Email: process@ikausa.com

UNITED KINGDOM

IKA England Ltd.

Phone: +44 1865 986 162

Email: sales.english@ika.com

INDIA

IKA India Private Limited

Phone: +91 80 26253 900

Email: process@ika.in

VIETNAM

IKA Vietnam Company Limited

Phone: +84 28 38202142

Email: sales.proc-vietnam@ika.com

BRAZIL

IKA Brazil

Phone: +55 19 3772-9600

Email: sales@ika.net.br

MALAYSIA

IKA Works (Asia) Sdn Bhd

Phone: +60 3 6099-5666

Email: sales.process@ika.my

CHINA

IKA Works Guangzhou

Phone: +86 20 8222 1771

Email: Sales-Proc@ika.cn

THAILAND

IKA Works (Thailand) Co., Ltd

Phone: +66 85 0999274

Email: sales.proc-Thailand@ika.com

KOREA

IKA Korea Ltd.

Phone: +82 2 2136 6800

Email: info@ika.kr

JAPAN

IKA Japan K.K.

Phone: +81 6 6730 6781

Email: info@ika.ne.jp



www.ikaprocess.com



[IKAworldwide](https://www.facebook.com/IKAworldwide) // #lookattheblue