

HD2303.0

Our instruments' quality level is the results of the product continuous development. This can bring about differences between the information written in this manual and the instrument that you have purchased. We cannot entirely exclude errors in the manual, for which we apologize.

The data, figures and descriptions contained in this manual cannot be legally asserted. We reserve the right to make changes and corrections without prior notice.



LAB Online Exhibition



Anemometer HD2303.0



HD2303.0

1. Input for probes, 8-pole DIN45326 connector.
2. Battery symbol: displays the battery charge level.
3. Function indicators.
4. Secondary display line.
5. **DATA/ENTER** key: during normal operation displays the maximum (MAX), the minimum (MIN) and the average (AVG) of current measurements; in the menu, confirms the current selection.
6. **CLR/ESC** key: resets the maximum, the minimum and the average of the captured measurements; in the menu, it resets the value set with the arrows.
7. **HOLD/▲** key: freezes the measurement during normal operation; in the menu, increases the current value.
8. **UNIT/MENU** key: it allows selection of the unit of measurement; when pressed together with the DATA key, it allows to open the menu.
9. **STD-BY**: during normal operation, it sets the hot-wire probe to stand-by; in the menu, changes the section's unit of measurement to m^2 or $inch^2$.
10. **REL/▼** key: during normal operation enables the relative measurement (displays the difference between the current value and the logged value when the key is pressed); in the menu, decreases the current value.
11. **ON-OFF/AUTO-OFF** key: turns the instrument on and off; when pressed together with the HOLD key, disables the *AutoPowerOff* function.
12. **MAX** (maximum value), **MIN** (minimum value) and **AVG** (average value) symbols.
13. Main display line.
14. Line for symbols and comments.

TABLE OF CONTENTS

1. GENERAL CHARACTERISTICS	5
2. DESCRIPTION OF THE FUNCTIONS	6
3. THE PROGRAMMING MENU	9
4. PROBES AND MEASUREMENTS	10
4.1 WIND SPEED MEASUREMENT	10
4.1.1 Flow rate measurement	11
4.2 HOT-WIRE WIND SPEED MEASUREMENT PROBES WITH SICRAM MODULE	12
4.2.1 Operation.....	14
4.2.2 Warnings, care and maintenance of the probes	15
4.2.3 Dimensions of the probes	15
4.3 VANE WIND SPEED MEASUREMENT PROBES WITH SICRAM MODULE	17
4.3.1 Calibration.....	17
4.3.2 Operation.....	17
4.3.3 Care and maintenance of the probes.....	18
4.3.4 Dimensions.....	19
4.4 DIRECT INPUT INTO Pt100 AND Pt1000 TEMPERATURE PROBES	21
4.4.1 Temperature measurement	21
4.4.2 Connecting the TP47 connector for the 4 wire Pt100 and 2 wire Pt1000 probes	21
4.4.3 Direct connection of 4 wire Pt100 sensors	22
5. WARNINGS	23
6. INSTRUMENT SIGNALS AND FAULTS	24
7. INSTRUMENT STORAGE	24
8. LOW BATTERY WARNING AND BATTERY REPLACEMENT	25
8.1 WARNING ABOUT BATTERY USE.....	25
9. NOTES ABOUT WORKING AND OPERATIVE SAFETY	26
10. TECHNICAL CHARACTERISTICS	27
10.1 TECHNICAL INFORMATION ON THE ANEMOMETER	27
10.2 ON LINE INSTRUMENT PROBES AND MODULES TECHNICAL DATA.....	28
10.2.1 Wind speed measurement probes	28
10.2.2 Temperature probes Pt100 sensor using SICRAM module.....	30
10.2.3 4 wire Pt100 and 2 wire Pt1000 Probes.....	30
11. ORDER CODES	31
11.1 PROBES COMPLETE WITH SICRAM MODULE	31
11.2 TEMPERATURE PROBES WITHOUT SICRAM MODULE	32

1. GENERAL CHARACTERISTICS

The Anemometer Model **HD2303.0** is a portable instrument that allows to perform measurements in the fields of air conditioning, heating and ventilation.

It is fitted with a large LCD display for excellent visualization of the measured data. The Anemometer Model **HD2303.0**:

- uses hot-wire or vane probes to measure **air speed**, **flow rate**, and **temperature** inside pipelines and vents;
- while **temperature** only is measured by immersion, penetration or contact probes; the temperature sensor is either a Pt100 or Pt1000.

The probes are fitted with the *automatic detection* module, with the factory calibration settings already being memorized inside.

The units of measurement for the measurable quantities are:

- for wind speed:
 - m/s (meter/second)
 - km/h (kilometer/hour)
 - ft/min (foot/minute)
 - mph (mile/hour)
 - knot
- for calculated flow rate:
 - l/s (liter/s)
 - m³/s (cubic meter/second)
 - m³/min (cubic meter/minute)
 - m³/h (cubic meter/hour)
 - ft³/s (cubic foot/second)
 - ft³/min (cubic foot/minute)

Using the Max, Min and Avg function of this instrument respectively obtains the maximum, minimum or average values.

Other available functions are:

- the relative measurement REL;
- the HOLD function;
- the automatic turning off which can also be disabled.

For further details see chapter 2.

2. DESCRIPTION OF THE FUNCTIONS

The keyboard of the Anemometer Model **HD2303.0** is composed of *double-function* keys. The function on the key is the "main function", while the one above the key is the "secondary function". When the instrument is in standard measurement mode, the main function is active.

Once the Settings Menu has been opened, by pressing simultaneously the **DATA+UNIT** keys, the secondary function is enabled.

The pressing of a key is accompanied by a short confirmation "beep": a longer "beep" sounds if the wrong key is pressed. Each key specific function is described in detail below.



ON-OFF and AUTO-OFF key

This key has two functions:

- **ON/OFF:** press this key to turn the instrument on and off.

The turning on enables all display segments for a few seconds and starts an **Auto-test** including the detection of the probe connected to the input. For a very short time the filter used for measurements (FAST or SLOW) is displayed; then the instrument carries on with the standard measurement.

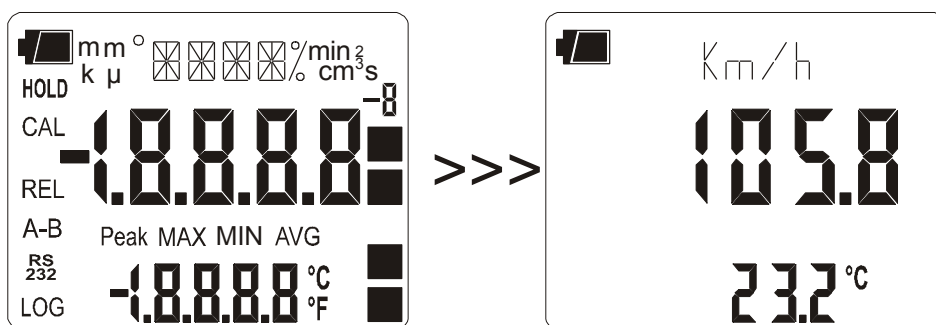

- **AUTO/OFF:** the *AutoPowerOff* function can be disabled by simultaneously pressing this key and the "HOLD" key when turning the instrument on.

During turning on, should no probes be connected, the "NO_PRBE_SER_NUM" message is displayed in the line for symbols for a few seconds, in the main line a series of dashes appears while the "ERR" message is shown in the secondary line.

Caution! As the data are captured upon turning the instrument on, it is necessary to turn it off and on again. Replace the probes when the instrument is off.



Disabling of the automatic turning off

The instrument has an *AutoPowerOff* function that automatically turns the instrument off after about 8 minutes if no key is pressed during the intervening time.

Press simultaneously the **ON/OFF** key and the **HOLD** key to disable this function.

In this case, remind to turn the instrument off with the **ON/OFF** key: the automatic turning off disabling is shown by the battery symbol blinking.

 CLR

CLR/ESC key

The "CLR" key has two functions:

- **CLEAR (CLR):** allows to reset the maximum (MAX), minimum (MIN) and average (AVG) value of the captured measurements;
- **ESC:** once the MENU has been opened with the **DATA+UNIT** keys, the **CLR** key will allow to cancel the parameters set using the ▲ and ▼ arrows.

 DATA

DATA/ENTER key

The "DATA" key is used for the following functions:

- **DATA:** during normal measurement, by pressing this key once the maximum (MAX) value of the measurements captured by the probe connected to the instrument is displayed, updating it with the acquisition of new samples;
 - by pressing this key again the minimum (MIN) value is displayed;
 - by pressing this key a third time the average (AVG) value is displayed.

The acquisition frequency is once a second.

The MAX, MIN and AVG values remain in the memory until the instrument is on, even after exiting the DATA calculation function. When the instrument is off, the previously memorized data are cleared. Upon turning on, the instrument automatically starts memorizing the MAX, MIN and AVG values.

To reset the previous values and start with a new measurement session, press **CLR** until the **FUNC_CLRD** message appears.

- **ENTER:** once the MENU has been opened with the **DATA+UNIT** keys, the **DATA** key will perform the ENTER function and the MENU can be browsed and the displayed parameter confirmed.

 HOLD

HOLD/▲ key

The "HOLD" key is used for the following functions:

- **HOLD:** by pressing this key the current measurement is frozen and the "HOLD" message will appear in the upper left-hand corner of the display. To return to the current measurement, press the key again.
- **▲:** once the MENU has been opened with the **DATA** and **UNIT** keys, the ▲ key will allow to increase the value of the selected parameter.

Pressed together with the **ON/OFF** key, during turn on, the *AutoPowerOff* function is disabled (see the description of the ON/OFF key).

UNIT**UNIT/MENU key**

The **UNIT** key is used for the following functions:

- **UNIT:** by pressing this key the unit of measurement of the main input quantity is selected: the unit of measurement will appear in the upper part of the display; the measured value will be displayed in the central line. By repeatedly pressing the **UNIT** key, the desired unit of measurement can be selected between the following:

- for wind speed: m/s - km/h - ft/min - mph - knot
- for calculated flow rate: l/s - m³/s - m³/min - m³/h - ft³/s - ft³/min

By now pressing **UNIT**, the m/s unit of measurement is displayed again in the comment line and, simultaneously, the unit of temperature measurement blinks. Use the ▲ and ▼ arrows, if you wish to change the temperature display from degrees Celsius (°C) to degrees Fahrenheit (°F), or vice-versa. Confirm by pressing the **UNIT** key or wait for the unit of measurement to stop blinking (about 15 seconds timeout).

- **MENU:** in the menu three items can be set (see chapter 3):
 1. **SECT m² - SECT inch²:** this parameter defines a duct's **section area** for flow rate calculation.
 2. The filter **FAST** or **SLOW** used during measurements
 3. **Probe type**
 - the menu is opened by pressing simultaneously **DATA+UNIT**: the first item of the instrument programming menu will appear;
 - use the ▲ and ▼ arrows (respectively located above the **HOLD** and **REL** keys) to **modify** the displayed value;
 - press **DATA/ENTER** to **confirm** the modification and go onto the next item;
 - press **CLR/ESC** to **cancel** the modification;
 - to **exit** the menu, press the **UNIT/MENU** key again.

STD-BY**STD-BY key**

- During normal operation, it sets the hot-wire probe to stand-by if the probe is connected to the input.
- In the menu, it changes the section's unit of measurement to inch² or m².

REL**REL/▼ key**

The "REL" key is used for the following functions:

- **REL:** it displays the difference between the current value and that measured on pressing the key for both measurements: main and secondary. The "REL" message is displayed on the left. To return to the normal measurement, press the key again.
- **▼:** once the MENU has been opened with the **DATA/UNIT** key, the ▼ key will allow to decrease the value of the selected parameter.

3. THE PROGRAMMING MENU

To access to the menu press simultaneously the following keys:



The items to be set are listed in this order:

1. **SECT m² - SECT inch²**: this parameter defines a duct's **section area** for flow rate calculation. It is expressed in **m²** or **inch²** (see par. 4.1.1);
 - use the ▲ and ▼ arrows (respectively located above the HOLD and REL keys) to **modify** the displayed value;
 - press **STD-BY** to change the unit of measurement to **m²** or **inch²**.
 - press **DATA/ENTER** to **confirm** the modification and go onto the next item;
 - press **CLR/ESC** to **cancel** the modification;
 - to **exit** the menu, press the **UNIT/MENU** key again.
2. **Sel Vel**: selection of filter used for speed and air flow rate to reduce, when necessary, the measurement fluctuations in case of any disturb phenomenon such as turbulences on diffuser outputs. Select FAST to exclude the filter, SLO (Slow) to use it.
 - to modify the displayed value, use the arrows UP and DOWN (placed respectively over the HOLD and REL keys)
 - push DATA/ENTER to confirm and go on to the next item, push DATA/ENTER;
 - push CLR/ESC to delete the modification;
 - push UNIT/MENU key again to quit.
3. **Probe type**: the "**PRBE_TYPE**" message is displayed in the comment line. The main line in the center of the display shows the type of probe connected to the instrument. The following probes can be connected to the input:
 - hot-wire probes complete with SICRAM module
 - vane probes complete with SICRAM module
 - temperature probes Pt100 complete with SICRAM module
 - direct 4 wire Pt100 probes complete with TP47 module
 - 2 wire Pt1000 probes complete with TP47 module

NOTE: Upon turning on the instrument automatically detects the probes fitted with SICRAM module. The type of probe is configured by the instrument and cannot be modified by the user.

Upon turning on the direct 4 wire Pt100 and Pt1000 temperature probes display the "**NO_PRBE_SER_NUM**" message. In this case the probe type must be entered manually by the user:

- use the ▲ and ▼ arrows (respectively located above the HOLD and REL keys) to **modify** the type of probe;
- press **DATA/ENTER** to **confirm** the modification and go onto the next item;
- press **CLR/ESC** to **cancel** the modification;
- to **exit** the menu, press the **UNIT/MENU** key again.

4. PROBES AND MEASUREMENTS

The Anemometer works with hot-wire, vane and temperature probes fitted with the SICRAM module. It works also with temperature probes with 4 wire Pt100 or 2 wire Pt1000 sensor.

Some probes are fitted with **SICRAM** module that acts as an interface between the sensor on the probe and the instrument. There is a microprocessor circuit with a permanent memory inside the module that enables the instrument to recognize the type of probe connected and to read its calibration information.

The temperature probes without SICRAM module are not automatically detected by the instrument and must be set up in the **Probe type** menu item (see chapter 3).

The probe is detected during turn on, and this cannot be performed when the instrument is already on, therefore if a probe is connected and the instrument is on, it is necessary to turn it off and on.

4.1 WIND SPEED MEASUREMENT

The probes of the **AP471** and **AP472** series measure the incident **wind speed** and **flow rate**. Some also measure air **temperature**.

The **measurement principles** used are the following:

- **hot-wire** for the **AP471** series
- **vane** for the **AP472** series.

On request, the probes of the AP471 and AP472 series can be fitted with a telescopic rod that eases measurements in areas difficult to reach (for example vents).

The **typical applications** are wind speed and flow rate checks in air conditioning, heating and cooling systems, or environmental comfort determination, etc.

The two probe models must be used according to the wind *speed*:

- hot-wire probes are usually employed for precise measurements with low-medium wind speeds (until 10 m/s);
- vane probes with speeds from 5 to 50m/s;

and according to the measured fluid *temperature*:

- hot-wire probes measure air flows at 80°C maximum temperature;
- vane probes measure air flows of up to 120°C, depending on the model.

Connecting the probe and turning the instrument on, it is possible to chose the unit of measurement for the value displayed in the main line by using the UNIT key.

The following units are available:

- for wind speed: m/s - km/h - ft/min - mph (miles/hour) - knots;
- for air temperature: °C and °F;
- for flow rate: l/s (liters/s) - m³/s - m³/min - m³/h - ft³/s - ft³/min.

4.1.1 Flow rate measurement

The flow rate measurement requires knowledge of the duct or vent area orthogonal to the flow: the menu items indicated by "SECT m2" and "SECT INC2" define the section area m^2 or $inch^2$.

To set the area value:

- press simultaneously **DATA** and **UNIT** to open the menu;
- using the **▲** and **▼** arrows, set the value expressed in m^2 ;
- confirm with **DATA/ENTER**.

To use the $inch^2$ unit of measurement:

- select the "SECT m2" menu item;
- press **STD-BY** to change the unit of measurement from m^2 to $inch^2$;
- using the **▲** and **▼** arrows, enter the desired value;
- press **DATA/ENTER** to **confirm** the modification and go onto the next item;
- press **CLR/ESC** to **cancel** the modification;
- to **exit** the menu, press the **UNIT/MENU** key again.

The area comprised must be between $0.0001m^2$ (1 cm^2) and 1.9999 m^2 .

After input of the duct's section area:

select the unit of measurement for the flow rate by using the **UNIT** key:

- l/s
- m^3/s
- m^3/min
- m^3/h
- ft^3/s
- ft^3/min .

The display shows the calculated flow rate on the section set with the parameters "SECT m2" and "SECT INC2".

4.2 HOT-WIRE WIND SPEED MEASUREMENT PROBES WITH SICRAM MODULE

The hot-wire wind speed measurement probes, fitted with SICRAM module, are the models:

- AP471 S1
- AP471 S2
- AP471 S3
- AP471 S4
- AP471 S5.

The **AP471 S1** and **AP471 S3** probes measure incident air flows up to 40m/s.

- The **AP471 S2**, **AP471 S4** and **AP471 S5** probes are fitted with an omnidirectional sensor allowing measurement of speeds up to 5m/s in any direction of the air flow incident on the probe.
- The **AP471 S4** probe is also fitted with support base and sensor protection.
- The **AP471 S5** is identical to the AP471 S4, but instead of a base it is provided with a telescopic rod. The wind speed measurement is compensated for according to temperature within the range of 0...+80°C.

The probes AP471S1, AP471 S2, and AP471S3 measure the environment temperature in the range of -30°C...+110°C; AP471 S4 and AP471S5 in the range 0°C...+80°C.

NOTE: The AP471S... modules are calibrated in the factory; no calibration is required by the user.

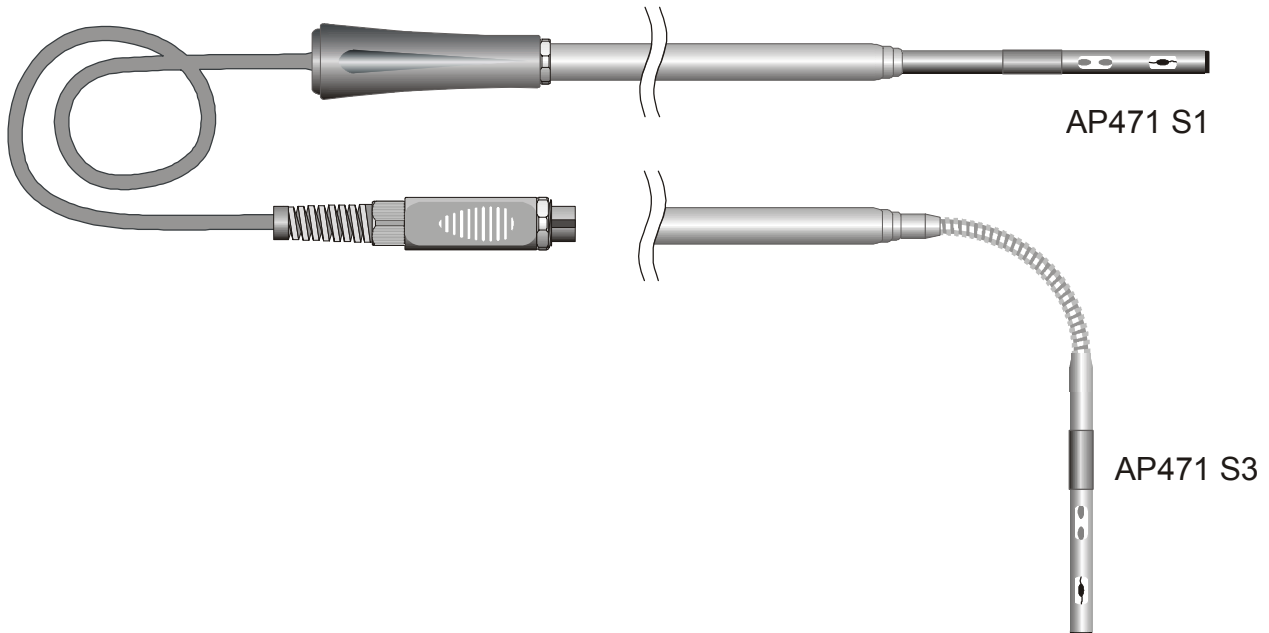

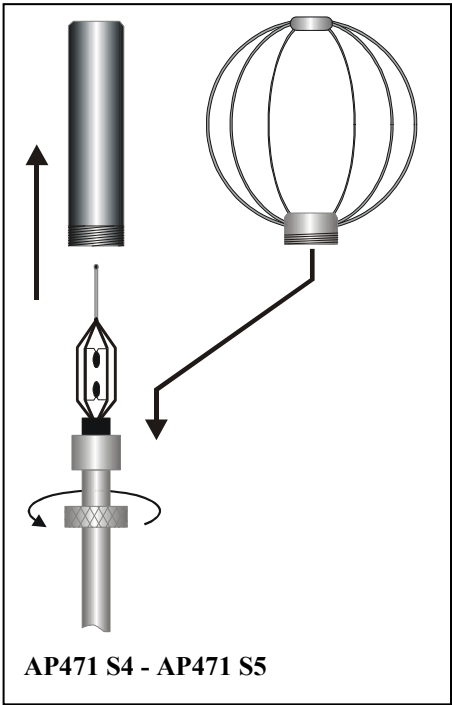

The AP471 S1, S2 and S3 probes are fitted with a cylindrical protection screen that can slide longitudinally over a groove. The screen has two end-of-travel positions that block it in measurement condition (completely low) or rest condition (completely high). To reduce the space occupied when not used, the AP471 S4 and AP471 S5 are supplied with a protection cylinder that can be screwed on the probe's head.

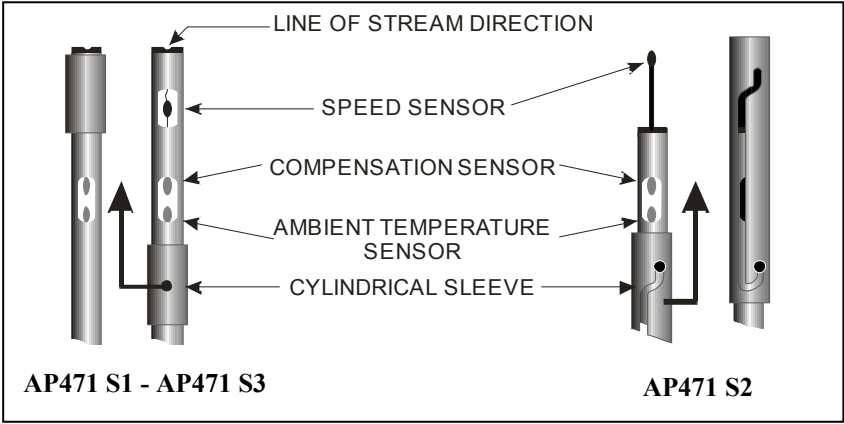

4.2.1 Operation

1. Extend the telescopic rod to the necessary length paying attention to the cable so that it can slide freely and without strain;
2. Uncover the sensor;
3. Introduce the probe in the air flow being measured, maintaining the arrow at the top of the probe parallel to the flow, as indicated in the figures.

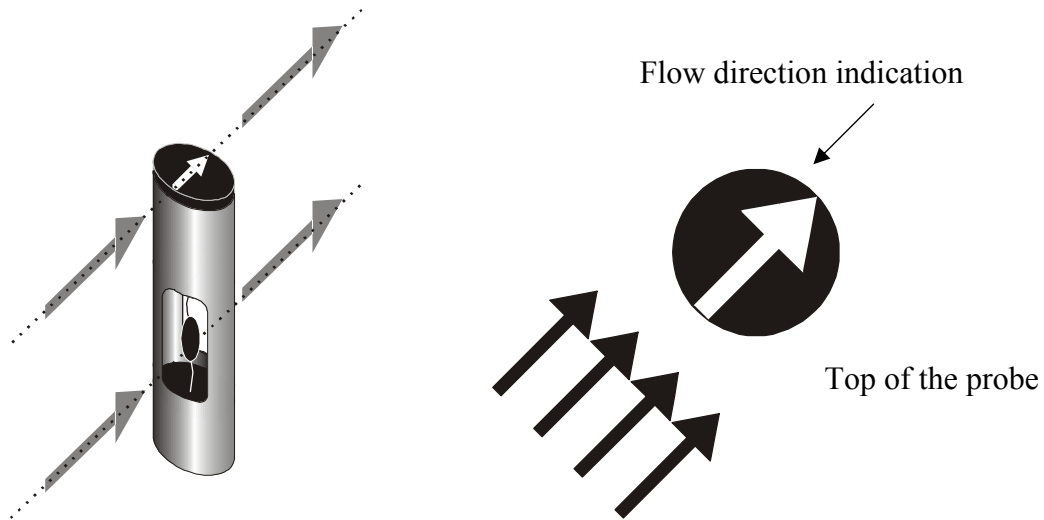

NOTE: the probe should be maintained orthogonal to the flow and not tilted in relation to it:

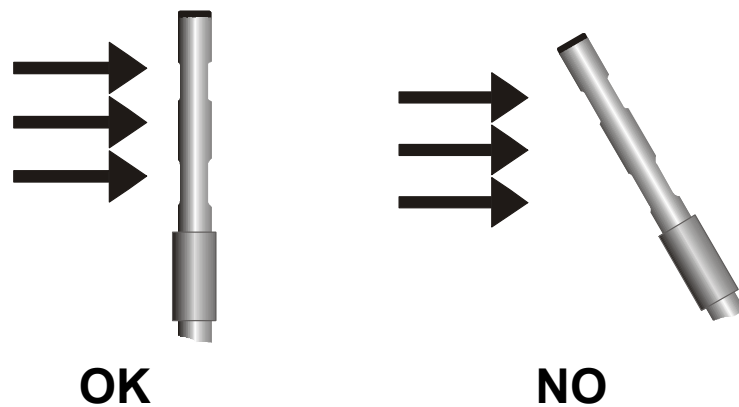

4. Proceed with measurement following the instructions provided in this chapter.

4.2.2 Warnings, care and maintenance of the probes



- The speed sensor of the AP471 Sx probes is heated and, **in the presence of gas vapours, could trigger a fire or explosion. Do not use the probe in the presence of inflammable gases. Ensure that no gas or explosive vapour leakage is present in the measurement spaces.**
- The probe is very delicate and should be handled with extreme care. Even a simple collision, especially of the omnidirectional probes that have an uncovered sensor, could render the probe unusable.
- After measurement, the sensor set on the probe head must be protected with the supplied metallic screen or threaded cylinder.
- During use, the AP471 S4 and AP471 S5 omnidirectional probes must be protected with the special metallic grid.
- During **transportation**, the sensor must be closed into the special cylinder screwed on the end part of the probe.
- Do not let fingers touch the sensors.
- Use only alcohol to **clean** the probe.

4.2.3 Dimensions of the probes

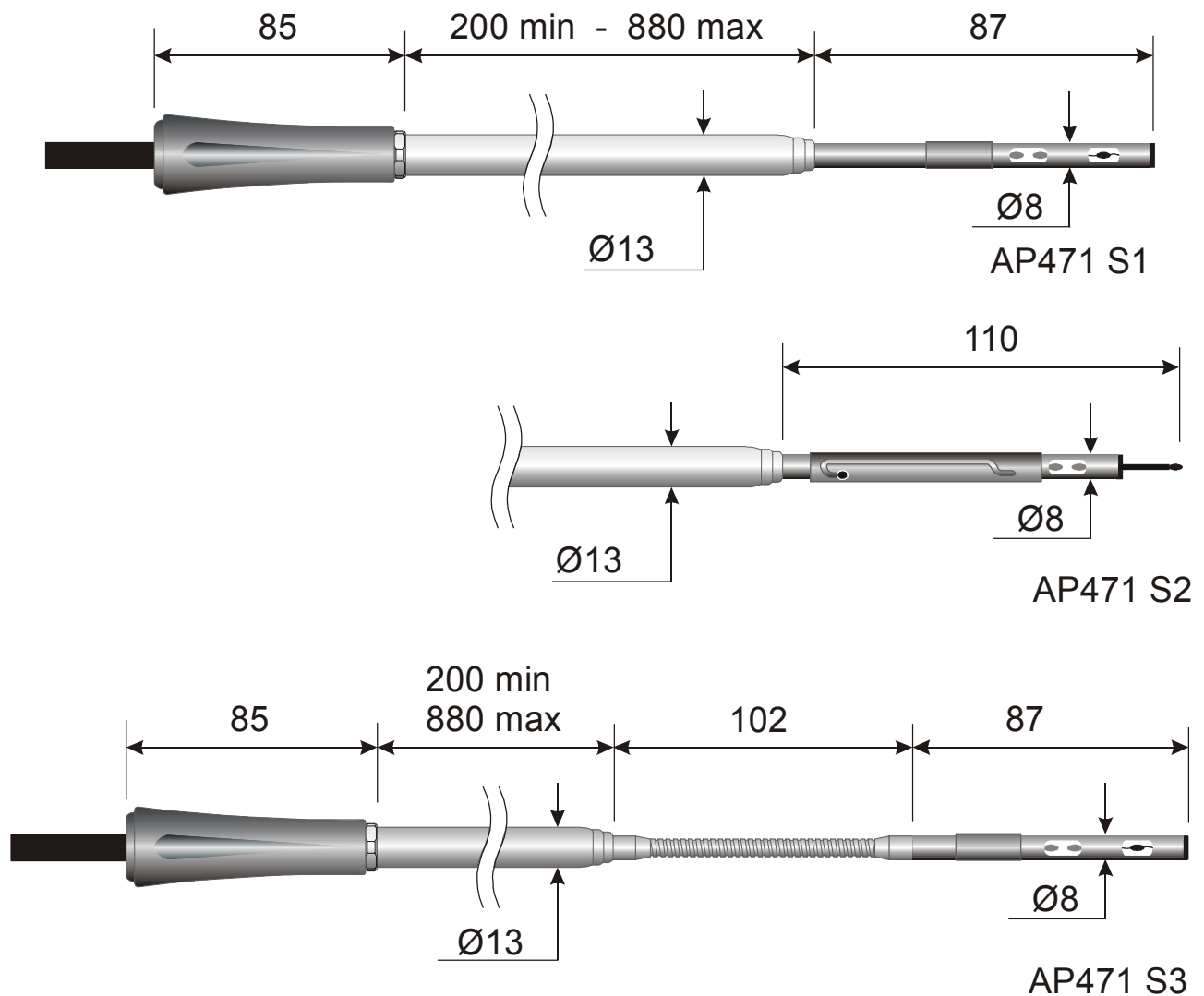

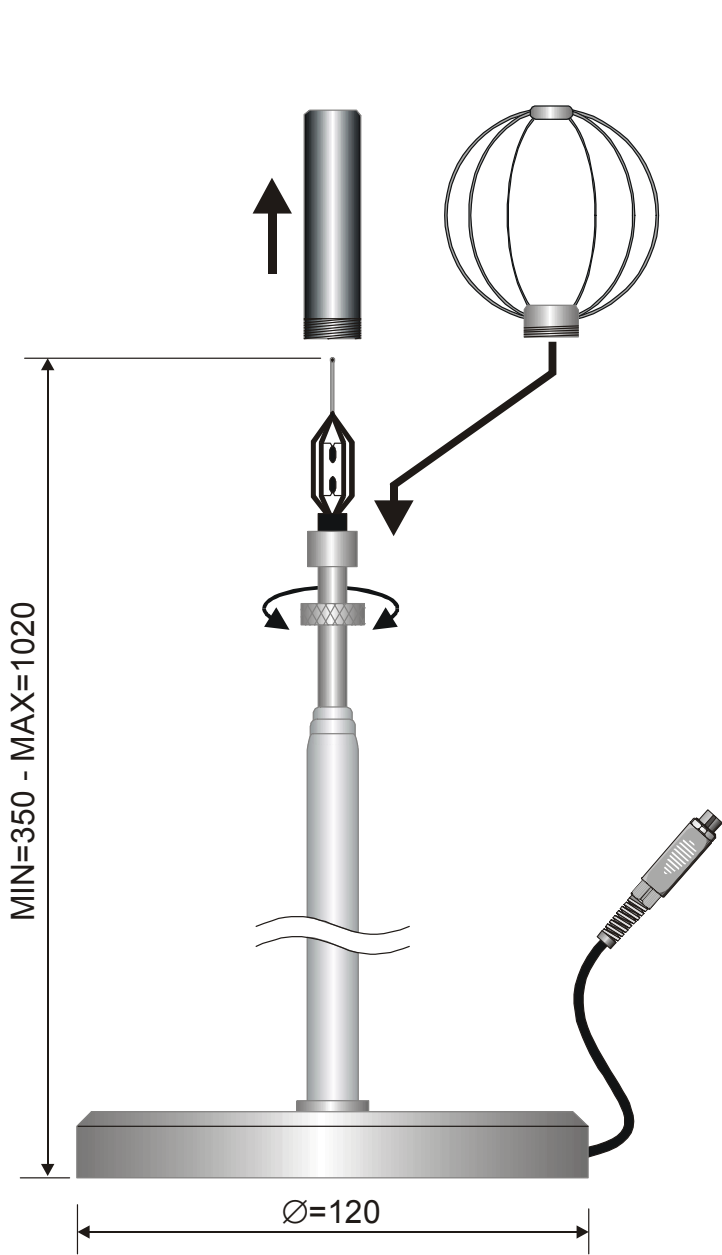

AP471 S4

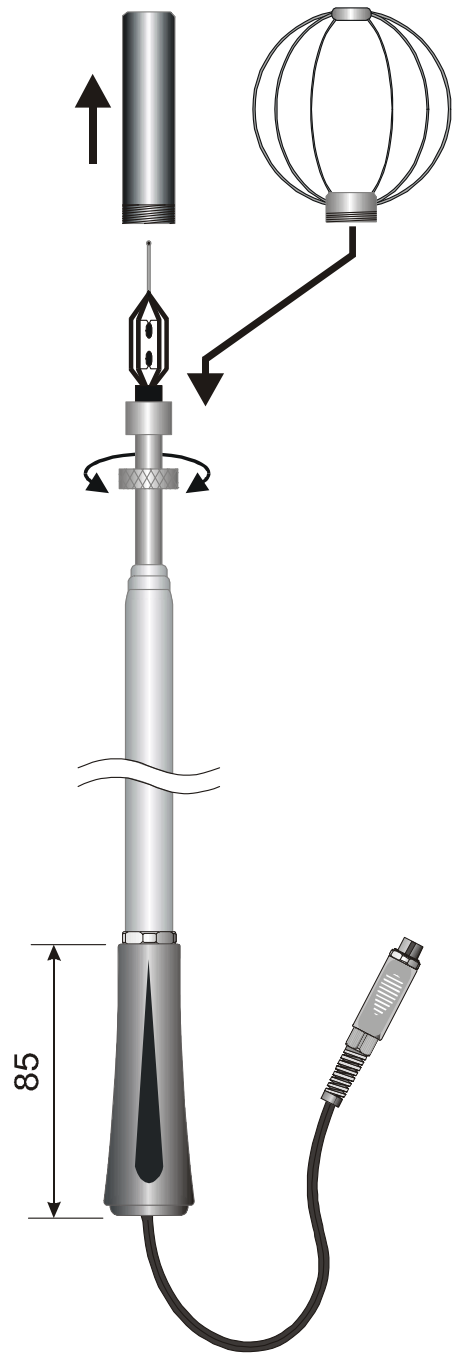

AP471 S5

4.3 VANE WIND SPEED MEASUREMENT PROBES WITH SICRAM MODULE

The AP472 S1, AP472 S2 and AP472 S4 vane probes measure the incident wind speed and flow rate.

The AP472 S1, AP472 S4LT and AP472 S4HT probes measure also the temperature using a thermocouple of type K. On request, they can be fitted with a telescopic rod that eases measurements in areas difficult to reach (for example vents). The probes' speed and temperature measurement ranges are outlined in the table below:

	Speed (m/s)	Temperature (°C)	Temperature sensor	Diameter (mm)
AP472 S1	0.6...25	-25...+80	Thermocouple K	100
AP472 S2	0.25...20	-25...+80 (functioning temperature)	----	60
AP472 S4L	0.6...20	-25...+80 (functioning temperature)	----	16
AP472 S4LT	0.6...20	-30...+120 (*)	Thermocouple K	16
AP472 S4H	10...50	-25...+80 (functioning temperature)	----	16
AP472 S4HT	10...50	-30...+120 (*)	Thermocouple K	16

(*) The temperature limit refers to the probe head, where the vane and temperature sensors are located, and not to the handle, cable and telescopic rod that can be subjected to maximum temperatures of 80°C.

- **Greater diameters** are suitable for flow measurements in the presence of turbulence with medium-low air speeds (i.e. at the exit of the ducts).
- **Lower diameters** are suitable in applications where the probe surface is much smaller than the duct cross section within which the measurement is carried out, i.e. ventilation ducts.

4.3.1 Calibration

The AP472 S1, AP472 S2 and AP472 S4 probes are calibrated in the factory: no calibration is required by the user.

4.3.2 Operation

1. Where present, extend the telescopic rod to the necessary length paying attention to the cable so that it can slide freely and without strain.
2. Introduce the probe in the air flow being measured, maintaining the arrow at the top of the probe parallel to the flow as indicated in the following figure.

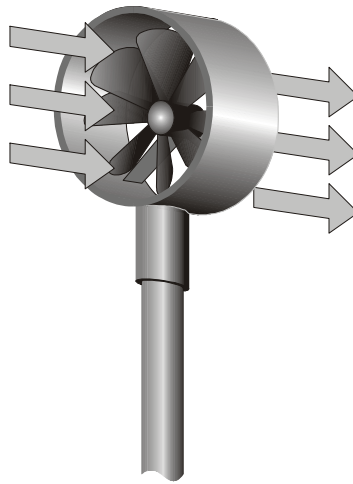

NOTE: the probe should be maintained orthogonal to the flow and not tilted in relation to it:

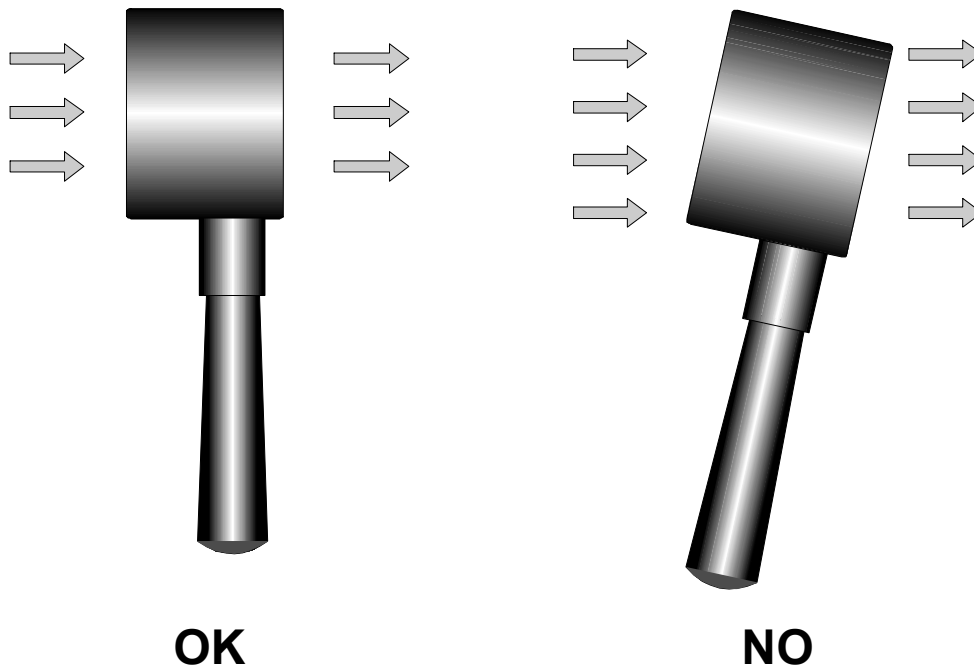

The probe is correctly positioned in relation to the air-flow when the value measured is the maximum possible.

3. Proceed with measurement following the instructions provided in the introductory paragraphs of this chapter.

4.3.3 Care and maintenance of the probes

The probe performance, mainly at low speeds, largely depends on the very slow friction of the vane on its own axis. In order not to compromise this characteristic, it is recommended that *forcing is avoided, as well as blocking or rotating the vane with the fingers, and if possible, avoid inserting it in air flows that could soil the probe, and do not exceed its measurement capacity.*

4.3.4 Dimensions

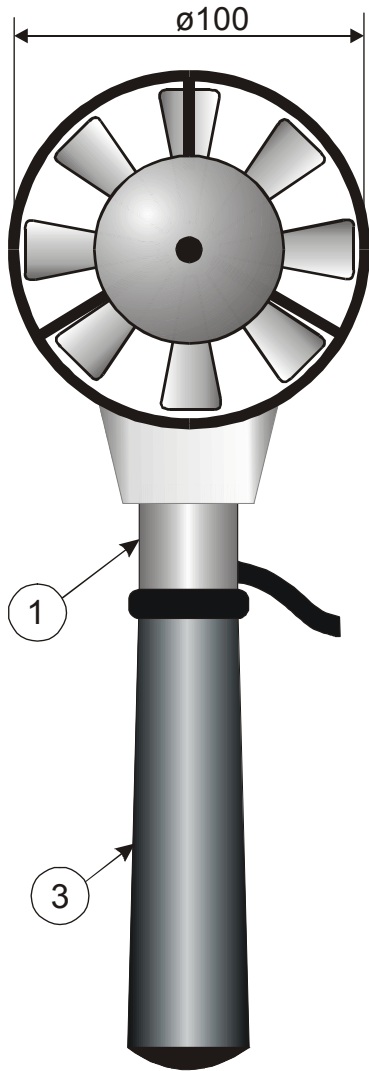

AP472 S1

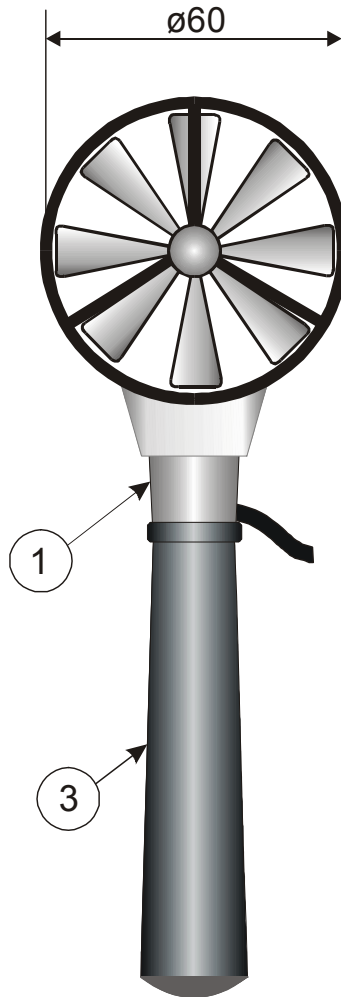

AP472 S2

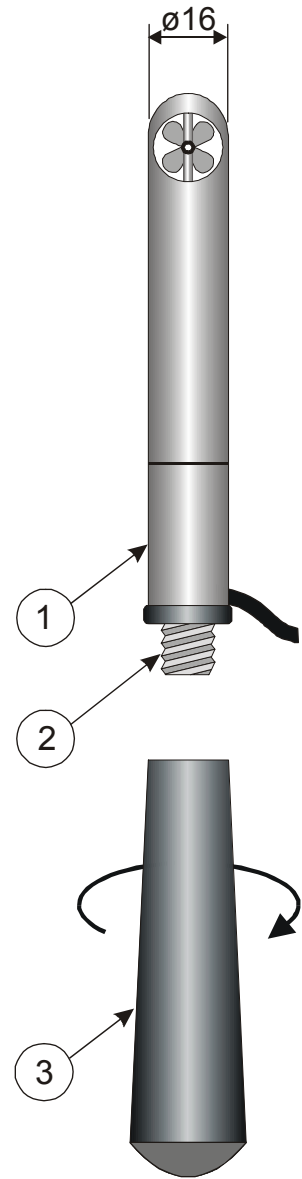

AP472 S4



Further to the telescopic extension shaft with the directional head, the probes AP472S1 – AP472S2 can be used with the stiff extension shaft diam.16mm. In order to screw the handle off (3) hold the probe tight on point (1). Screw the shaft top AP471S1.23.6 on the screw (2). Other extension shafts AP471S1.23.6 can be added. The handle (3) or the extension shaft AP471A1.23.7 (6) are the last element.

The probe AP472S4 can be used only with the stiff extension shafts AP471S1.23.6.

4.4 DIRECT INPUT INTO Pt100 AND Pt1000 TEMPERATURE PROBES

The instrument accepts the input of Platinum temperature probes with resistances of 100Ω (Pt100) and 1000Ω (Pt1000).

The Pt100 are connected to 4 wires, the Pt1000 to 2 wires; the excitation current was chosen in order to minimize the sensor self-heating effects.

All probes with SICRAM module are calibrated in the factory; the 2 or 4 wire probes with direct input are **checked for conformity with class A tolerance** according to norm IEC751 - BS1904 - DIN43760.

For the temperature probes without SICRAM module (Pt100 4 wires, and Pt1000) the model configuration is required (please see the description of the Probe Type menu, chapter 3).

4.4.1 Temperature measurement

The temperature measurement by **immersion** is carried out by inserting the probe in the liquid for at least 60 mm; the sensor is housed in the end part of the probe.

In the temperature measurement by **penetration** the probe tip must be inserted to a depth of at least 60 mm, the sensor is housed in the end part of the probe.

NOTE: when measuring the temperature on frozen blocks it is convenient to use a mechanical tool to bore a cavity in which to insert the tip probe.

In order to perform a correct **contact** measurement, the measurement surface must be even and smooth, and the probe must be perpendicular to the measurement plane.

So as to obtain the correct measurement, the insertion of a drop of oil or heat-conductive paste between the surface and the probe is useful (do not use water or solvents). This method also improves the response time.

4.4.2 Connecting the TP47 connector for the 4 wire Pt100 and 2 wire Pt1000 probes

All probes produced by Delta Ohm are provided with a connector.

The **HD2303.0** instrument also work with direct 4 wire Pt100, and 2 wire Pt1000 probes manufactured by other producers: for the instrument connection is prescribed the **TP47** connector to which the probe's wires should be welded.



The instructions to connect the Platinum probe to the TP47 module are provided below. The **TP47** module is supplied complete with fairlead and gasket for 5 mm maximum diameter cables. Do the following to open the module and connect a probe:

1. unscrew the fairlead;
2. extract the gasket;
3. remove the label using a cutter;
4. unscrew the ring on the opposite side as illustrated in the figure:

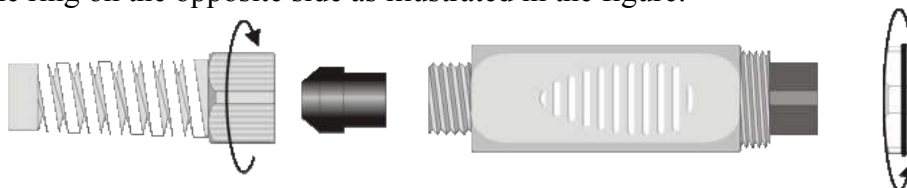

- open the two module shells: the printed circuit to which the probe must be connected is housed inside. On the left there are the 1...4 points on which the sensor wires must be welded. The JP1...JP4 jumpers are in the center of the board. These must be closed with a tin bead for some type of sensors:

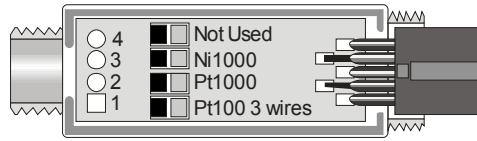

Caution! Before welding, pass the probe cable through the fairlead and gasket.

- Weld the wires as shown in the table:

Sensor	Board connection	Jumper to close
Pt100 4 wires		None
Pt1000 2 wires		JP2

Ensure the welds are clean and perfect.

- Once the welding operation is complete, close the two shells;
- insert the gasket in the module;
- screw the fairlead and the ring. Make sure the cable is not twisted while you are screwing the fairlead. Now the probe is ready.

4.4.3 Direct connection of 4 wire Pt100 sensors

Sensor	Direct soldering to the connector
Pt100 4 wires	<p>View of the soldering side of the flying female connector</p>

4 wire Pt100 sensors can be soldered directly to the pins of the flying female connector without making use of the TP47 board. The 4 wires of the Pt100 sensors have to be soldered as indicated in the figure on the left. In order to use this type of probe it is necessary to set up the menu item "Probe Type" as described at page 9. The P100 probe is recognized upon turning on the instrument: connect the probe when the instrument is switched off and then turn it on.

5. WARNINGS

1. Temperature probes are not insulated from their external casing; be very careful not to come into contact with live parts (above 48V). This could be extremely dangerous for the instrument as well as for the operator, who could be electrocuted.

2. Do not expose the probes to gases or liquids that could corrode the material of the sensor or the probe itself. Clean the probe carefully after each measurement.
3. Do not bend the probe connectors or force them upward or downward.
4. Do not bend or force the contacts when inserting the probe connector into the instrument.
5. Do not bend, deform or drop the probes, as this could cause irreparable damage.
6. Always select the most suitable probe for your application.
7. Do not use the temperature probes in presence of corrosive gases or liquids. The sensor container is made of AISI 316 stainless steel, while the contact probe container is made from AISI 316 stainless steel plus silver. Avoid contact between the probe surface and any sticky surface or product that could corrode or damage it.
8. Above 400°C and below -40°C, avoid violent blows or thermal shocks to Platinum temperature probes as this could cause irreparable damage.
9. To obtain reliable measurements, temperature variations that are too rapid must be avoided.
10. Temperature probes for surface measurements (contact probes) must be held perpendicular against the surface. Apply oil or heat-conductive paste between the surface and the probe in order to improve contact and reduce reading time. Whatever you do, do not use water or solvent for this purpose. A contact measurement is always very hard to perform. It has high levels of uncertainty and depends on the ability of the operator.
11. Temperature measurements on non-metal surfaces usually require a great deal of time due to the low heat conductivity of non-metal materials.
12. Avoid taking measurements in presence of high frequency sources, microwave ovens or large magnetic fields; results may not be very reliable.
13. Clean the probe carefully after use.
14. The instrument is water resistant and IP67, but should not be immersed in water. The probe connectors must be fitted with sealing gaskets. Should the instrument fall into the water, check for any water infiltration. Gently handle the instrument in such a way as to prevent any water infiltration from the connectors' side.

6. INSTRUMENT SIGNALS AND FAULTS

The following table lists all error indications and information displayed by the instrument and supplied to the user in different operating situations:

Display indications	Explanation
- - -	This appears in the display central line when a temperature only probe is connected. In the lower line the temperature is shown correctly.
>>> PRBE TYPE	type of probe connected
BATT TOO LOW CHNG NOW	Indication of insufficient battery charge appearing on turning on. The instrument issues a long beep and turns off. Replace the batteries.
CAL LOST	Program error: it appears after turning on for a few seconds. Contact the instrument's supplier.
ERR	This appears if the probe has already been detected by the instrument, but is disconnected. At the same time an intermittent beep is issued.
FUNC CLR D	max, min and average values cleared
NO PRBE SER NUM	the connected probe's serial number is absent
OVER	Measurement overflow: indicates that the probe is measuring a value exceeding the measuring range.
PLS_EXIT >>> FUNC RES FOR FACT ONLY	please exit using ESC >>> function reserved to factory calibration
PRBE SER #####	serial number ##### of the connected probe
PROB ERR	A probe with SICRAM module has been inserted when not admissible for that specific instrument.
PROB COMM LOST	This appears if the probe has already been detected by the instrument, but is disconnected. At the same time an intermittent beep is issued.
SECT inch ²	section in inch ²
SECT m ²	section in m ²
SYS ERR #	Instrument management program error. Contact the instrument's supplier and communicate the numeric code # reported by the display.

7. INSTRUMENT STORAGE

Instrument storage conditions:

- Temperature: -25...+65°C.
- Humidity: less than 90%RH without condensation.
- Do not store the instrument in places where:
 - humidity is high;
 - the instrument may be exposed to direct sunlight;
 - the instrument may be exposed to a source of high temperature;
 - the instrument may be exposed to strong vibrations;
 - the instrument may be exposed to steam, salt or any corrosive gas.

The instrument case is made of ABS plastic: do not use any incompatible solvent for cleaning.

8. LOW BATTERY WARNING AND BATTERY REPLACEMENT

The battery symbol  on the display constantly shows the battery charge status. To the extent that batteries have discharged, the symbol "empties". When the charge decreases still further it starts blinking.



In this case, batteries should be replaced as soon as possible.

If you continue to use it, the instrument can no longer ensure correct measurement. The memory data are maintained.

If the battery charge level is insufficient, the following message appears when you turn the instrument on:

**BATT TOO LOW
CHNG NOW**

The instrument issues a long beep and turns off. In this case, replace the batteries in order to turn the instrument back on.

To replace the batteries, proceed as follows:

1. switch the instrument off;
2. unscrew the battery cover counter clockwise;
3. replace the batteries (3 1.5V alkaline batteries - type AA);
4. screw the cover on clockwise.



Malfunctioning upon turning on after battery replacement

After replacing the batteries, the instrument may not restart correctly; in this case, repeat the operation.

After disconnecting the batteries, wait a few minutes in order to allow circuit condensers to discharge completely; then reinsert the batteries.

8.1 WARNING ABOUT BATTERY USE

- Batteries should be removed when the instrument is not used for an extended time.
- Flat batteries must be replaced immediately.
- Avoid batteries leaking.
- Always use good quality leakproof alkaline batteries. Sometimes on the market, it is possible to find new batteries with an insufficient charge capacity.

9. NOTES ABOUT WORKING AND OPERATIVE SAFETY

Authorized use

The technical specifications as given in chapter TECHNICAL CHARACTERISTICS must be observed. Only the operation and running of the measuring instrument according to the instructions given in this operating manual is authorized. Any other use is considered unauthorized.

General safety instructions

This measuring system is constructed and tested in compliance with the EN 61010-1 safety regulations for electronic measuring instruments. It left the factory in a safe and secure technical condition.

The smooth functioning and operational safety of the measuring system can only be guaranteed if the generally applicable safety measures and the specific safety instructions in this operating manual are followed during operation.

The smooth functioning and operational safety of the instrument can only be guaranteed under the environmental and electrical operating conditions that are in specified in chapter TECHNICAL CHARACTERISTICS.

Do not use or store the product in places such as listed below:

- Rapid changes in ambient temperature which may cause condensation.
- Corrosive or inflammable gases.
- Direct vibration or shock to the instrument.
- Excessive induction noise, static electricity, magnetic fields or noise.

If the measuring system was transported from a cold environment to a warm environment, the formation of condensate can impair the functioning of the measuring system. In this event, wait until the temperature of the measuring system reaches room temperature before putting the measuring system back into operation.

Obligations of the purchaser

The purchaser of this measuring system must ensure that the following laws and guidelines are observed when using dangerous substances:

- EEC directives for protective labour legislation
- National protective labour legislation
- Safety regulations

10. TECHNICAL CHARACTERISTICS

10.1 TECHNICAL INFORMATION ON THE ANEMOMETER

Instrument

Dimensions (Length x Width x Height)	140 x 88 x 38 mm
Weight	160 g (complete with batteries)
Material	ABS
Display	2x4½ digits plus symbols Visible area: 52 x 42 mm

Operating conditions

Operating temperature	-5 ÷ 50°C
Warehouse temperature	-25 ÷ 65°C
Working relative humidity	0 ÷ 90%RH without condensation
Protection degree of the case	IP67

Power

Batteries	3 1.5V type AA batteries
Autonomy (*)	200 hours with 1800mAh alkaline batteries
Power absorbed with instrument off	< 20 µA

Connections

Input for probes	8-pole male DIN45326 connector
------------------	--------------------------------

Unit of Measurement

m/s-km/h-ft/min-mpg-knot
l/s-m³/s-m³/min-m³/h-ft³/s-ft³/min
°C - °F;

Measurement of temperature by Instrument

Pt100 measurement range	-200 ÷ +650 °C
Pt1000 measurement range	-200 ÷ +650°C
Resolution	0.1 °C
Accuracy	±0.1 °C
Drift after 1 year	0.1 °C/year

EMC standard regulations

Security	EN61000-4-2, EN61010-1 level 3
Electrostatic discharge	EN61000-4-2 level 3
Electric fast transients	EN61000-4-4 level 3, EN61000-4-5 level 3
Voltage variations	EN61000-4-11
Electromagnetic interference susceptibility	IEC1000-4-3
Electromagnetic interference emission	EN55020 class B

(*) Valid for all probes except hot-wire probes. For their autonomy see the characteristics below.

10.2 ON LINE INSTRUMENT PROBES AND MODULES TECHNICAL DATA

10.2.1 Wind speed measurement probes

Hot-wire probes: AP471 S1 - AP471 S2 - AP471 S3 - AP471 S4 - AP471 S5

	AP471 S1 - AP471 S3	AP471 S2	AP471 S4 AP471 S5
<i>Type of measurements</i>	Wind speed, calculated flow rate, air temperature		
<i>Type of sensor</i>			
Speed	NTC thermistor	Omnidirectional NTC thermistor	
Temperature	NTC thermistor	NTC thermistor	
<i>Measurement range</i>			
Speed	0.05...40m/s	0.05...5m/s	
Temperature	-30...+110°C	-30...+110°C	0...80°C
<i>Measurement resolution:</i>			
Speed	0.01 m/s 0.1 km/h 1 ft/min 0.1 mph 0.1 knot		
Temperature	0.1°C		
<i>Measurement accuracy</i>			
Speed	±0.1 m/s (0.05...0.99 m/s) ±0.2 m/s (1.00...9.99 m/s) ±0.6 m/s (10.00...40.0 m/s)	±0.02m/s (0.05...0.99 m/s) ±0.1m/s (1.00...5.00 m/s)	
Temperature	±0.4°C (-30...+110°C)	±0.4°C (-30...+110°C)	
Minimum speed	0.05 m/s		
Air temperature compensation	0...80°C		
Battery life	Approx. 20 hours @ 20 m/s with alkaline batteries	Approx. 30 hours @ 5 m/s with alkaline batteries	
<i>Unit of Measurement</i>			
Speed	m/s – km/h – ft/min – mph – knot		
Flow rate	l/s - m ³ /s - m ³ /min - m ³ /h - ft ³ /s - ft ³ /min		
Pipeline section for flow rate calculation	0.0001...1.9999 m ²		
Cable length	~2m		

Vane probes: AP472 S1... - AP472 S2 - AP472 S4...

	AP472 S1	AP472 S2	AP472 S4...			
			...L	...LT	...H	...HT
<i>Type of measurements</i>	Wind speed, calculated flow rate, air temperature	Wind speed, calculated flow rate	Wind speed, calculated flow rate.	Wind speed, calculated flow rate, air temperature.	Wind speed, calculated flow rate.	Wind speed, calculated flow rate, air temperature.
<i>Diameter</i>	100 mm	60 mm	16 mm			
<i>Type of measurement</i>			Vane			
Speed	Vane	Vane				
Temperature	K thermocouple	----	----	K thermo couple	----	K thermo couple
<i>Measurement range</i>						
Speed (m/s)	0.6...25	0.3...20	0.8...20		10...50	
Temperature (°C)	-25...+80 (*)	-25...+80 (*)	-25...+80 (*)	-30...+120 (**)	-25...+80 (*)	-30...+120 (**)
<i>Resolution</i>						
Speed			0.01 m/s 0.1 km/h 1 ft/min 0.1 mph 0.1 knot			
Temperature	0.1°C	----	----	0.1°C	----	0.1°C
<i>Accuracy</i>						
Speed	±(0.2 m/s +1.5%f.s.)	±(0.2m/s +1.5%f.s.)	±(0.3 m/s +1.5%f.s.)			
Temperature	±0.5°C	----	----	±0.5°C	----	±0.5°C
<i>Minimum speed</i>	0.6m/s	0.3m/s	0.8m/s		10m/s	
<i>Unit of Measurement</i>						
Speed			m/s – km/h – ft/min – mph – knot			
Flow rate			l/s - m ³ /s - m ³ /min - m ³ /h - ft ³ /s - ft ³ /min			
<i>Pipeline section for flow rate calculation</i>			0.0001...1.9999 m ²			
<i>Cable length</i>			~2m			

(*) The indicated value refers to the vane's working range.

(**) The temperature limit refers to the probe head, where the vane and temperature sensors are located, and not to the handle, cable and telescopic rod that can be subjected to maximum temperatures of 80°C.

10.2.2 Temperature probes Pt100 sensor using SICRAM module

Model	Type	Application range	Accuracy
TP472I	Immersion	-196°C...+500°C	±0.25°C (-196°C...+350°C) ±0.4°C (+350°C...+500°C)
TP472I.0	Immersion	-50°C...+400°C	±0.25°C (-50°C...+350°C) ±0.4°C (+350°C...+400°C)
TP473P.0	Penetration	-50°C...+400°C	±0.25°C (-50°C...+350°C) ±0.4°C (+350°C...+400°C)
TP474C.0	Contact	-50°C...+400°C	±0.3°C (-50°C...+350°C) ±0.4°C (+350°C...+400°C)
TP475A.0	Air	-50°C...+250°C	±0.3°C (-50°C...+250°C)
TP472I.5	Immersion	-50°C...+400°C	±0.3°C (-50°C...+350°C) ±0.4°C (+350°C...+400°C)
TP472I.10	Immersion	-50°C...+400°C	±0.3°C (-50°C...+350°C) ±0.4°C (+350°C...+400°C)
TP875	Globe thermometer Ø 150mm	-10°C...+100°C	±0.25°C

Common characteristics

Resolution	0.1°C
Temperature drift @20°C	0.003%/°C

10.2.3 4 wire Pt100 and 2 wire Pt1000 Probes

Model	Type	Application range	Accuracy
TP47.100	4 wire Pt100	-50...+400°C	Class A
TP47.1000	2 wire Pt1000	-50...+400°C	Class A

Common characteristics

Resolution	0.1°C
Temperature drift @20°C	
Pt100	0.003%/°C
Pt1000	0.005%/°C

11. ORDER CODES

HD2303.0 The kit is composed of the HD2303.0, 3 1.5V alkaline batteries, operating manual, and case. **The probes must be ordered separately.**

11.1 PROBES COMPLETE WITH SICRAM MODULE

WIND SPEED MEASUREMENT PROBES

• HOT-WIRE PROBES

- AP471 S1** Hot-wire telescopic probe, measuring range: 0.05...40m/s. Cable length 2 metres.
- AP471 S2** Omnidirectional hot-wire telescopic probe, measuring range: 0.05...5m/s. Cable length 2 metres.
- AP471 S3** Hot-wire telescopic probe with terminal tip for easy position, measuring range: 0.05...40m/s. Cable length 2 metres.
- AP471 S4** Omnidirectional hot-wire telescopic probe with base, measuring range: 0.05...5m/s. Cable length 2 metres.
- AP471 S5** Omnidirectional hot-wire telescopic probe, measuring range: 0.05...5m/s. Cable length 2 metres.

• VANE PROBES

- AP472 S1** Vane probe with thermocouple, Ø 100mm. Speed from 0.6 to 25m/s; temperature from -25 to 80°C. Cable length 2 metres.
- AP472 S2** Vane probe, Ø 60mm. Measurement range: 0.3...20m/s. Cable length 2 metres.
- AP472 S4L** Vane probe, Ø 16mm. speed from 0.8 to 20m/s. Cable length 2 metres.
- AP472 S4LT** Vane probe with thermocouple, Ø 16mm, speed from 0.8 to 20m/s. Temperature from -30 to 120°C with thermocouple K sensor (*). Cable length 2 metres.
- AP472 S4H** Vane probe, Ø 16mm speed from 10 to 50m/s. Cable length 2 metres.
- AP472 S4HT** Vane probe with thermocouple, Ø 16mm speed from 10 to 50m/s. Temperature from -30 to 120°C with thermocouple K sensor (*). Cable length 2 metres.

(*) The temperature limit refers to the probe head, where the vane and temperature sensors are located, and not to the handle, cable and telescopic rod that can be subjected to maximum temperatures of 80°C.

TEMPERATURE MEASUREMENT PROBES

TP472I	Pt100 sensor immersion probe. Stem Ø 3 mm, length 300 mm. Cable length 2 metres.
TP472L.0	Pt100 sensor immersion probe. Stem Ø 3 mm, length 230 mm. Cable length 2 metres.
TP473P.0	Pt100 sensor penetration probe. Stem Ø 4 mm, length 150 mm. Cable length 2 metres.
TP474C.0	Pt100 sensor contact probe. Stem Ø 4 mm, length 230 mm, contact surface Ø 5 mm. Cable length 2 metres.
TP475A.0	Pt100 sensor air probe. Stem Ø 4 mm, length 230 mm. Cable length 2 metres.
TP472L.5	Pt100 sensor immersion probe. Stem Ø 6 mm, length 500 mm. Cable length 2 metres.
TP472L.10	Pt100 sensor immersion probe. Stem Ø 6 mm, length 1000 mm. Cable length 2 metres.
TP875	Globe thermometer Ø 150 mm with handle, complete with SICRAM module. Cable length 2 metres.

11.2 TEMPERATURE PROBES WITHOUT SICRAM MODULE

TP47.100	Direct 4 wire Pt100 sensor immersion probe. Probe's stem Ø 3 mm, length 230 mm. 4 wire connection cable with connector, length 2 metres.
TP47.1000	Pt1000 sensor immersion probe. Probe's stem Ø 3 mm, length 230 mm. 2 wire connection cable with connector, length 2 metres.
TP47	Only connector for probe connection: direct 4 wire Pt100, 2 wire Pt1000.

CERTIFICATO DI CONFORMITÀ DEL COSTRUTTORE

MANUFACTURER'S CERTIFICATE OF CONFORMITY

rilasciato da

issued by

DELTA OHM SRL STRUMENTI DI MISURA

DATA
DATE

2009/01/29

Si certifica che gli strumenti sotto riportati hanno superato positivamente tutti i test di produzione e sono conformi alle specifiche, valide alla data del test, riportate nella documentazione tecnica.

We certify that below mentioned instruments have been tested and passed all production tests, confirming compliance with the manufacturer's published specification at the date of the test.

La riferibilità delle misure ai campioni internazionali e nazionali delle unità del SIT è garantita da una catena di riferibilità ininterrotta che ha origine dalla taratura dei campioni di laboratorio presso l'Istituto Primario Nazionale di Ricerca Metrologica.

The traceability of measures assigned to international and national reference samples of SIT units is guaranteed by a uninterrupted reference chain which source is the calibration of laboratories samples at the Primary National Metrological Research Institute.

Tipo Prodotto: **Anemometro**
Product Type: **Anemometer**

Nome Prodotto: **HD2303.0**
Product Name:

Responsabile Qualità
Head of Quality

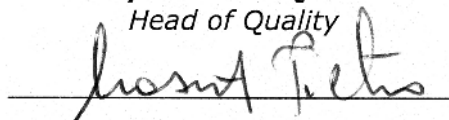

DELTA OHM SRL
35030 Caselle di Selvazzano (PD) Italy
Via Marconi, 5

Tel. +39.0498977150 r.a. - Telefax +39.049635596
Cod. Fisc./P.Iva IT03363960281 - N.Mecc. PD044279
R.E.A. 306030 - ISC. Reg. Soc. 68037/1998

GUARANTEE



GUARANTEE CONDITIONS

All DELTA OHM instruments have been subjected to strict tests and are guaranteed for 24 months from date of purchase. DELTA OHM will repair or replace free of charge any parts which it considers to be inefficient within the guarantee period. Complete replacement is excluded and no request of damages are recognized. The guarantee does not include accidental breakages due to transport, neglect, incorrect use, incorrect connection to voltage different from the contemplated for the instrument. Furthermore the guarantee is not valid if the instrument has been repaired or tampered by unauthorized third parties. The instrument has to be sent to the retailer without transport charge. For all disputes the competent court is the Court of Padua.



The electric and electronic devices with the following symbol cannot be disposed in the public dumps. According to the Directive UE 2002/96/EC, the European users of electric and electronic devices are allowed to give back to the Distributor or Manufacturer the used device at the time of purchasing a new one. The illegal disposing of electric and electronic devices is punished by a pecuniary administrative penalty.

This guarantee must be sent together with the instrument to our service centre.

N.B.: Guarantee is valid only if coupon has been correctly filled in all details.

Instrument type **HD2303.0**

Serial number _____

RENEWALS

Date _____	Date _____
Inspector _____	Inspector _____
Date _____	Date _____
Inspector _____	Inspector _____
Date _____	Date _____
Inspector _____	Inspector _____



CE CONFORMITY	
Safety	EN61000-4-2, EN61010-1 LEVEL 3
Electrostatic discharge	EN61000-4-2 LEVEL 3
Electric fast transients	EN61000-4-4 LEVEL 3
Voltage variations	EN61000-4-11
Electromagnetic interference susceptibility	IEC1000-4-3
Electromagnetic interference emission	EN55020 class B