



# New Brunswick™ HEF® and G Freezers

Operating manual



# ***LAB Online Exhibition***



## **Copyright**

Copyright © 2015 Eppendorf AG, Germany. No part of this publication may be reproduced without the prior permission of the copyright owner.

The company reserves the right to change information in this document without notice. Updates to information in this document reflect our commitment to continuing product development and improvement.

## **Trademarks**

Eppendorf® and the Eppendorf logo are registered trademarks of Eppendorf AG, Germany.

New Brunswick™ is a trademark of Eppendorf AG, Germany.

BioCommand® is a registered trademark of Eppendorf, Inc., USA.

Innova® is a registered trademark of Eppendorf, Inc., USA.

HEF® is a registered trademark of Eppendorf, Inc., USA.

S.M.A.R.T. Plus™ is a pending trademark of Eppendorf, Inc., USA.

Trademarks are not marked in all cases with ™ or ® in this manual.

Eppendorf has attempted to identify the ownership of all trademarks from public records. Any omissions or errors are unintentional.

## Table of contents

<b>1</b>	<b>Operating instructions</b>	<b>7</b>
1.1	Using this manual	7
1.2	Danger symbols and danger levels	7
1.2.1	Hazard symbols	7
1.2.2	Degrees of danger	7
1.3	Symbols used	8
1.4	Abbreviations used	8
<b>2</b>	<b>Safety</b>	<b>11</b>
2.1	Intended use	11
2.2	Warnings for intended use	11
2.2.1	Manual conventions used	11
2.2.2	Health and safety at work act 1974	12
<b>3</b>	<b>Product description</b>	<b>13</b>
3.1	Main illustration	13
3.2	Delivery package	15
3.2.1	Inspection of boxes	15
3.2.2	Packing list verification	15
3.3	Product versions	16
3.3.1	Introduction	16
3.4	Features	17
<b>4</b>	<b>Installation</b>	<b>19</b>
4.1	Preparing installation	19
4.2	Selecting the location	19
4.2.1	Occupancy rating (230 V, 50 Hz models only)	19
4.2.2	Below ground installations (230 V, 50 Hz models only)	19
4.2.3	Installation categories (230 V, 50 Hz models only)	20
4.3	Mains/Power plugs and receptacles	20
4.4	Requirements for water-cooled models	21
4.5	Connecting multiple water-cooled freezers	22
4.5.1	Connecting freezers to a recirculating chiller	22
4.5.2	Connecting freezers to the non-recirculating water supply (no chiller)	23
4.6	Water flow rate	23
4.7	Installing the shelves	24
4.7.1	Maximum freezer shelf load	24
4.8	Lockable freezer handle	24
<b>5</b>	<b>Operating controls and function</b>	<b>27</b>
5.1	Controls and function	27
<b>6</b>	<b>Operation</b>	<b>31</b>
6.1	Getting started	31
6.1.1	Plug in	31
6.1.2	Turning the freezer On/Off	31
6.1.3	Alarm/battery activation	33
6.1.4	Testing the alarm monitoring socket	34

**Table of contents**

New Brunswick™ HEF® and G Freezers  
English (EN)

6.1.5	Vacuum effect . . . . .	34
6.2	Programming the freezer . . . . .	34
6.2.1	Setting operating temperature . . . . .	34
6.2.2	Setting high alarm setpoint. . . . .	35
6.2.3	Setting low alarm setpoint . . . . .	35
6.2.4	Checking temperature and alarm setpoint settings . . . . .	36
6.2.5	Setting the alarm delay . . . . .	36
6.2.6	Changing lock codes . . . . .	37
6.2.7	Setting the temperature offset . . . . .	37
6.3	Battery backup switch. . . . .	38
6.4	RS-485 Connection . . . . .	38
6.5	Alarm monitoring socket. . . . .	39
<b>7</b>	<b>Maintenance . . . . .</b>	<b>43</b>
7.1	Cleaning . . . . .	43
7.1.1	Painted surfaces . . . . .	43
7.1.2	Interior and shelves. . . . .	43
7.1.3	Air intake grill and filter . . . . .	43
7.1.4	Heated vent port . . . . .	43
7.1.5	Door or lid seal . . . . .	44
7.2	Routine maintenance . . . . .	45
7.2.1	Lubrication . . . . .	45
7.2.2	Defrosting . . . . .	45
7.2.3	Removing the inner doors (upright models). . . . .	45
7.2.4	Replacing the inner door (U725-G). . . . .	46
7.2.5	Replacing the inner door (Premium HEF upright models). . . . .	46
7.2.6	Electrical components. . . . .	47
7.3	Service safety checklist. . . . .	48
<b>8</b>	<b>Troubleshooting . . . . .</b>	<b>51</b>
8.1	General errors. . . . .	51
8.2	Error messages . . . . .	51
8.3	After a mains/power failure. . . . .	52
8.4	Interior warming . . . . .	52
<b>9</b>	<b>Technical data. . . . .</b>	<b>55</b>
<b>10</b>	<b>Ordering information . . . . .</b>	<b>61</b>
10.1	Accessories . . . . .	61
10.1.1	TCA-3 temperature monitoring system. . . . .	61
10.1.2	Auto-dialers. . . . .	61
10.1.3	Temperature probes . . . . .	61
10.1.4	Validation packages . . . . .	61
10.1.5	Padlock adapter kits . . . . .	61
10.1.6	CO <sub>2</sub> and LN <sub>2</sub> back-up systems . . . . .	61
10.1.7	Inventory racking systems . . . . .	62
10.1.8	Chart recorder. . . . .	62
10.1.9	BioCommand SFI datalogging software (RS-485 interface) . . . . .	62

- 11 Transport, storage and disposal ..... 63**
  - 11.1 Shut down ..... 63
  - 11.2 Transport ..... 63
  - 11.3 Disposal ..... 64
  
- Index ..... 65**
  
- Certificates ..... 69**

**Table of contents**

New Brunswick™ HEF® and G Freezers  
English (EN)





# 1 Operating instructions

## 1.1 Using this manual

- ▶ Carefully read this operating manual before using the device for the first time.
- ▶ Also observe the operating manual enclosed with the accessories.
- ▶ The operating manual should be considered as part of the product and stored in a location that is easily accessible.
- ▶ When passing the device on to third parties, be sure to include this operating manual.
- ▶ If this manual is lost, please request another one. The latest version can be found on our website [www.eppendorf.com](http://www.eppendorf.com).

## 1.2 Danger symbols and danger levels

### 1.2.1 Hazard symbols

	<b>Hazard point</b>		<b>Freezer burn</b>
	<b>Electric shock</b>		<b>Material damage</b>
	<b>Crush</b>		

### 1.2.2 Degrees of danger

The following degree levels are used in safety messages throughout this manual. Acquaint yourself with each item and the potential risk if you disregard the safety message.

<b>DANGER</b>	<i>Will</i> lead to severe injuries or death.
<b>WARNING</b>	<i>May</i> lead to severe injuries or death.
<b>CAUTION</b>	May lead to light to moderate injuries.
<b>NOTICE</b>	May lead to material damage.

**Operating instructions**

New Brunswick™ HEF® and G Freezers  
English (EN)

## 1.3 Symbols used

Example	Meaning
▶	You are requested to perform an action.
1. 2.	Perform these actions in the sequence described.
•	List.
	References useful information.

## 1.4 Abbreviations used

**A**

Amp

**CFC**

Chlorofluorocarbons

**°C**

Degree Celsius

**G**

Green

**HEF**

High Efficiency

**HCFC**

Hydrochlorofluorocarbon

**Hz**

Hertz

**kg**

Kilogram

**lb**

Pound

**m**

Meter

**min**

Minute

**mm**

Millimeter

**N/A**  
Not applicable

**rpm**  
Revolutions per Minute (min<sup>-1</sup>)

**ULT**  
Ultra-Low Temperature

**V**  
Volt

**Operating instructions**

New Brunswick™ HEF® and G Freezers  
English (EN)

## 2 Safety

### 2.1 Intended use

HEF® and G (Green) freezers are designed to provide precise, ultra-low temperature environments for storage of scientific materials for research purposes. They are designed to provide ultra-low temperature sample storage from -50 °C to -86 °C at 32 °C maximum ambient operating temperature.

### 2.2 Warnings for intended use

#### 2.2.1 Manual conventions used



**WARNING! Risk of personal injury**

- ▶ BEFORE connecting the freezer to the mains/power supply, make sure that the mains/power supply matches the requirements of the equipment. Check the specification plate (located on the side of the freezer) for the electrical requirements. The equipment should be connected to an earth/grounded socket.



**WARNING! Risk of personal injury**

- ▶ Flammable warning messages alert you to possible risks of personal injury and equipment damage: protect the system from sparks and flames.



**CAUTION! Risk of personal injury**

- ▶ Use freezer gloves at all times when loading or unloading the equipment. The temperature of operation is such that direct contact with the cold contents or inside the equipment can burn unprotected skin.



**CAUTION! Risk of personal injury**

- ▶ Do not use this equipment in a hazardous atmosphere or with hazardous materials for which the equipment was not designed.
- ▶ Please read the entire operating manual before attempting to use this equipment. If operational guidelines are not followed, personal injury may occur.



**CAUTION! Risk of personal injury**

- ▶ Crush Warning messages alert you to specific procedures or practices regarding heavy objects which, if not followed correctly, could result in serious personal injury.

**Safety**

New Brunswick™ HEF® and G Freezers  
English (EN)

**NOTICE! Risk of material damage**

- ▶ This equipment must be operated as described in this manual.
- ▶ Please read the entire operating manual before attempting to use this equipment. If operational guidelines are not followed, equipment damage may occur.

## 2.2.2 Health and safety at work act 1974

(FOR THE UNITED KINGDOM)

Eppendorf, as manufacturers and suppliers of laboratory equipment, are obliged under the terms of the above Act to provide our users with instructions on the safe installation, operation and maintenance of our equipment.

Our equipment is designed to acceptable standards and does not entail any hazard if used, as advised in the attached instructions.

The following safety precautions should be observed by all personnel using this equipment:

1. Read and understand this manual. If in doubt, contact your local Eppendorf sales office.
2. Do not remove any covers. There are no operable controls other than those referred to in this manual. There are voltages in excess of 41.5 volts AC behind the covers.
3. Observe good housekeeping practices, at all times keeping the equipment and the adjacent areas clean, dry and uncluttered.
4. Should any malfunctions occur or be suspected, immediately call a qualified service engineer to investigate.  
The hydrocarbon (Group A3) refrigerants used in these freezers are flammable and therefore appropriate attention must be paid to avoid leaks and to keep the freezer away from sparks and flames.

Any person involved with working on or entering the refrigeration circuit should hold a current and valid certificate from an industry-accredited assessment authority which authorizes his/her competence to handle refrigerants (including hydrocarbons) safely in accordance with local regulations and legislation.

### 3 Product description

#### 3.1 Main illustration

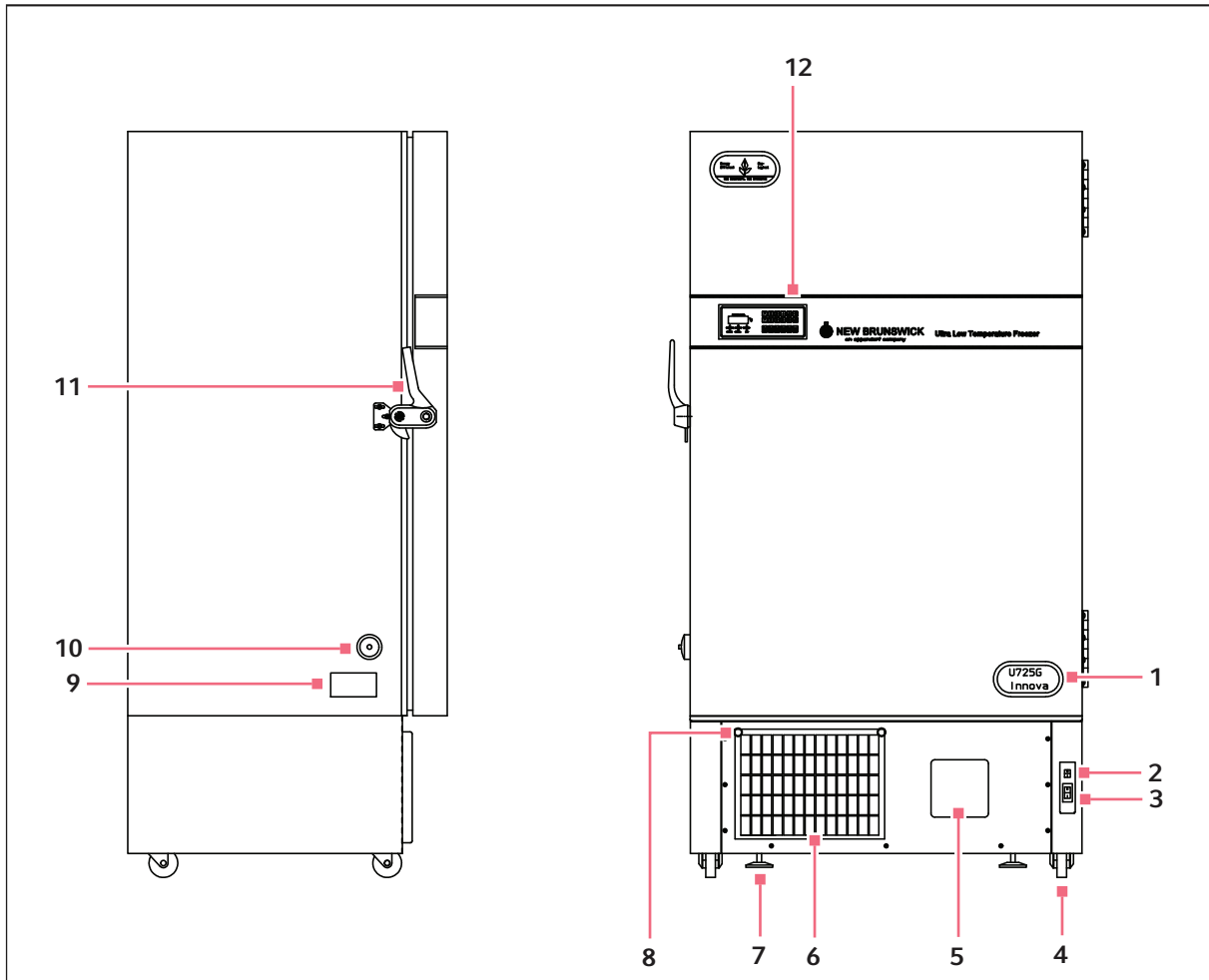

Fig. 3-1: Upright freezer - Side and front views

- |  |                           |
|--|---------------------------|
| 1 Model label                                  | 7 Adjustable feet         |
| 2 Battery switch behind lockable panel         | 8 Quarter turn fastener   |
| 3 On/Off circuit breaker behind lockable panel | 9 Specification plate     |
| 4 Transport castors                            | 10 Heated vent port       |
| 5 Chart recorder (optional)                    | 11 Door handle (lockable) |
| 6 Air filter grill                             | 12 Control panel/display  |

**Product description**

New Brunswick™ HEF® and G Freezers  
English (EN)

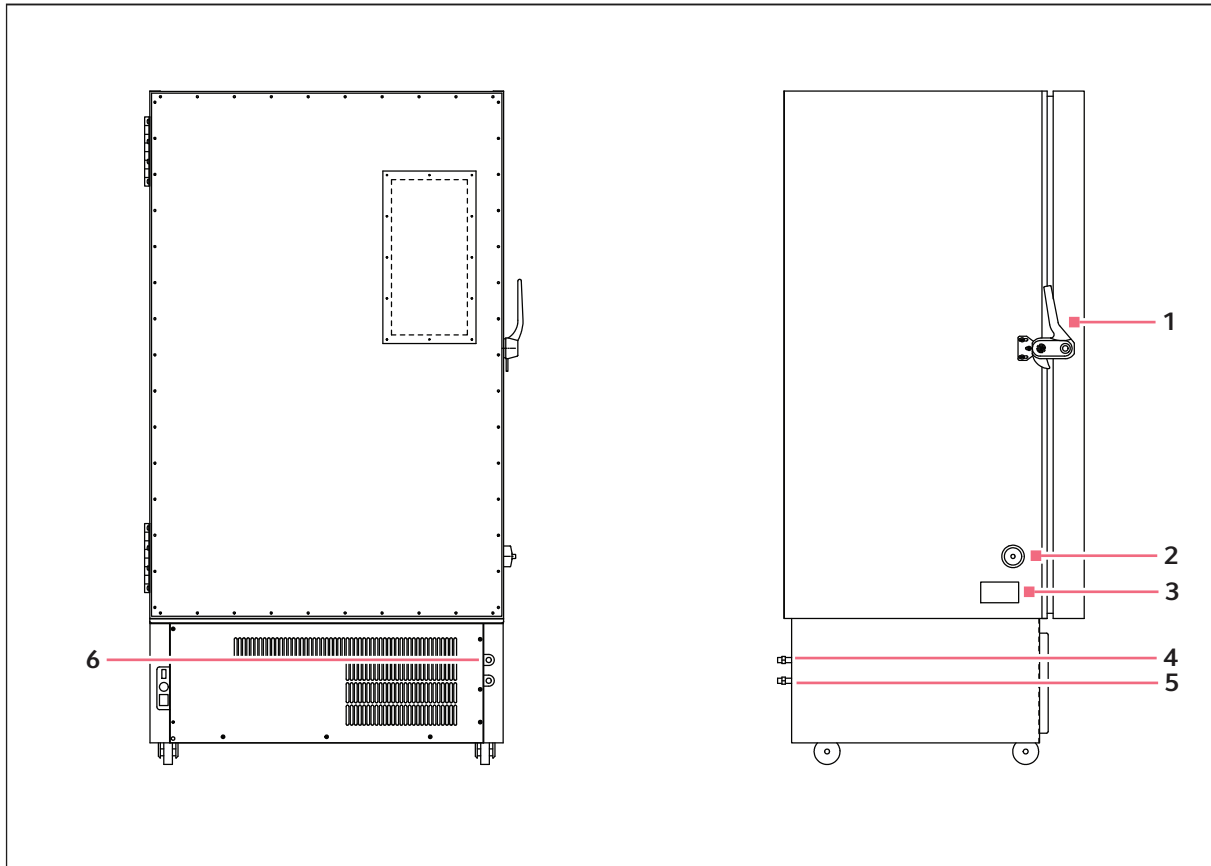

Fig. 3-2: Water-cooled freezer - Rear and side views

**1 Door handle (lockable)**

**2 Heated vent port**

**3 Specification plate**

**4 Water out**

**5 Water in**

**6 Water connection (1/2" BSP)**

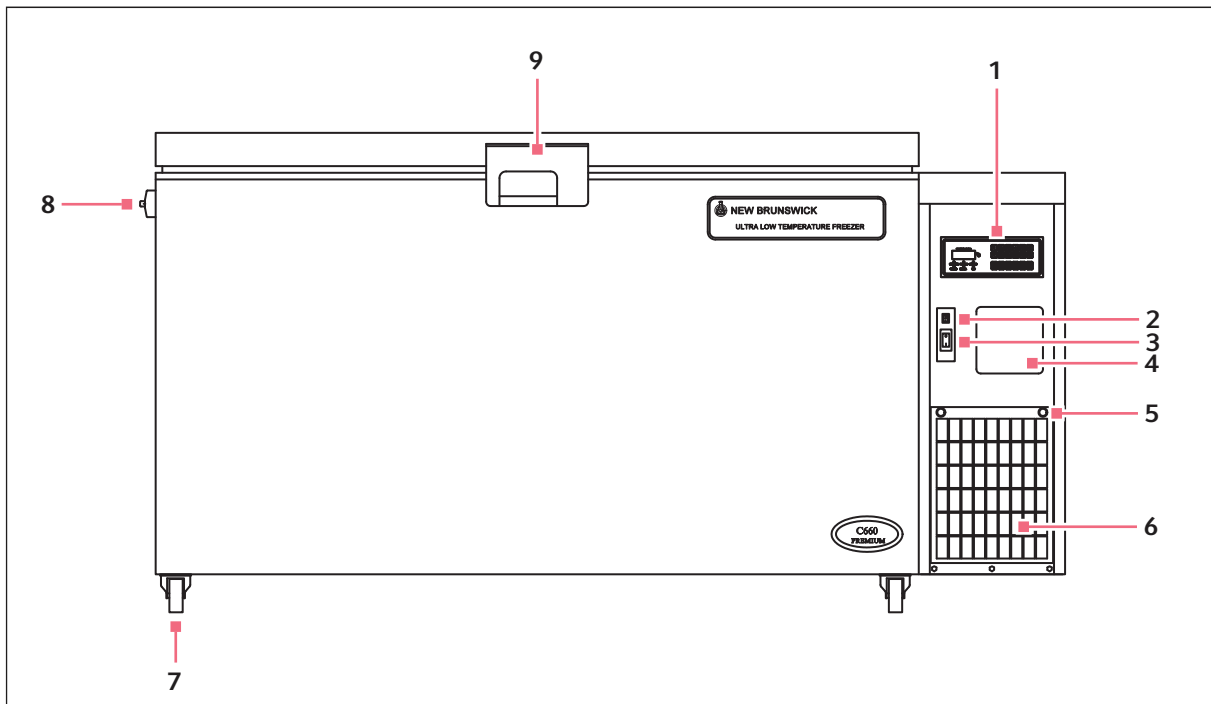

Fig. 3-3: Chest freezer - Front view

- |  |  |
|--|--|
| 1 Control panel/display                        | 6 Air filter grill                             |
| 2 Battery switch (alarm) behind lockable panel | 7 Braked castors (front)                       |
| 3 On/Off circuit breaker behind lockable panel | 8 Heated vent port (inside compressor housing) |
| 4 Chart recorder (optional)                    | 9 Lockable handle                              |
| 5 Quarter turn fasteners                       |  |

### 3.2 Delivery package

#### 3.2.1 Inspection of boxes

Inspect the boxes carefully for any damage that may have occurred during shipping. Report any damage to the carrier and to your local Eppendorf Sales Order Department immediately.

#### 3.2.2 Packing list verification

Unpack your order, saving the packing materials for possible future use. Save the operating manual for instruction and reference. Verify against your packing list that you have received the correct materials, and that nothing is missing. If any part of your order was damaged during shipping, is missing, or fails to operate, fill out the "Customer Feedback" form, available online at <http://www.eppendorf.com/OC-en/about-us/about-eppendorf/contact-us/>.

**Product description**

New Brunswick™ HEF® and G Freezers  
English (EN)

**NOTICE! Risk of material damage**

- ▶ Vacuum insulation panels are used in the construction of Innova U725G and U410 HEF, U570 HEF, and C660 HEF model freezers. Inspect the cabinet panels for punctures or other damage that compromises the integrity of the product.
- ▶ These panels are mounted in the cavity against the steel outer wall of the freezer. Any drilling or puncture to the outer wall could release the vacuum from the panel, resulting in impaired freezer performance.

**3.3 Product versions****3.3.1 Introduction**

This manual provides the user with the necessary information for installation and operation of Eppendorf line of energy saving HEF and G range of Ultra-Low Temperature freezers: Innova® U725G, and the HEF models. It also provides some preliminary user maintenance information.

This manual covers the following freezer models:

<b>Model (230 V, 50 Hz)</b>	<b>Capacity</b>
Innova U725-G Air-cooled	725 liters (25.6 cubic feet)
Innova U725-G Water-cooled	725 liters (25.6 cubic feet)
U410 HEF	410 liters (14.5 cubic feet)
U570 HEF	570 liters (20.1 cubic feet)
C660 HEF	660 liters (23.3 cubic feet)

All the above mentioned HEF and G freezers are totally free of CFCs (Chlorofluorocarbons) and HCFCs (Hydrochlorofluorocarbons). They use HCs (Hydrocarbons) as refrigerants.



The use of Hydrocarbons as refrigerant is prohibited in the United States.

The following HEF freezer models utilize HFCs (Hydrofluorocarbons) as refrigerants, and are offered for the United States market.

<b>Model (115 V, 60 Hz)</b>	<b>Capacity</b>
U410 HEF	410 liters (14.5 cubic feet)
U570 HEF	570 liters (20.1 cubic feet)

<b>Model (208 - 230 V, 60 Hz)</b>	<b>Capacity</b>
C660 HEF	660 liters (23.3 cubic feet)

### 3.4 Features

The freezers are manufactured using high quality steel and electronics for long life. The HEF and G-Series freezers have many features designed to provide ease of use and maintenance, security and reliability to your ultra-low temperature storage needs. They are built to stringent regulatory requirements for safety and environmental friendliness and disposability, and they are CE and UL certified.

Features include:

- Designed to be exceptionally energy efficient and eco-friendly.
- A setpoint keypad and digital temperature readout are provided on a control panel, located on the door of the upright freezers and on the console on the right side of chest freezers. Controls for setting the freezer temperature and alarm warning setpoints are enabled by an electronic lock. A unique code, which is selected by the user through the keypad, sets this lock. The code can be changed at any time, provided the current setting of the lock is known. **On delivery, the lock code is "0000" (unlocked).**
- Indicator lamps on the control panel provide warnings of power loss, system failure, exceeding High/Low temperature setpoints, low battery voltage, and filter blockage. There is also an LED to indicate when the freezer is under remote control via the RS-485 optional computer interface.
- Heavy-duty commercially available compressors provide rapid temperature pull-down and recovery after door opening.
- A heated port with ice-clearing plunger prevents vacuum formation enabling the outer door to be easily opened at anytime.
- All interior panels and shelves are made of high grade corrosion-resistant stainless steel, making them durable and easy to keep clean and sterilize.
- Heavy duty castors enable easy installation and relocation.
- Two access ports allow easy addition of sensors, or of back-up systems that can provide cooling protection for your samples in the case of a power outage or other system failure.
- An alarm contact is provided for connection to an external monitoring device or system.
- The freezers can be fitted with an optional 7-day circular chart recorder to provide independent temperature recording.
- An automatic reset restarts freezers at random 15 second intervals to protect the microprocessor controller from damage by electrical spikes caused by multiple freezers turning on at once.
- Lockable freezer handles on outer door provide added security against unauthorized users.
- Multiple accessories are offered, including CO<sub>2</sub>/LN<sub>2</sub> back-up systems, remote monitoring systems, external voltage stabilizer, inventory racking, and more.

**Product description**

New Brunswick™ HEF® and G Freezers  
English (EN)

## 4 Installation

### 4.1 Preparing installation



#### **WARNING! Risk of personal injury**

- ▶ DO NOT attempt to lift any freezer by hand. Preferred lifting for loading and unloading is by mechanical lifting equipment.



#### **NOTICE! Risk of material damage**

- ▶ Maintenance, adjustment and repair work should be carried out only by QUALIFIED, EXPERIENCED personnel who have been AUTHORIZED to undertake such work by Eppendorf or its authorized agents.

### 4.2 Selecting the location

All freezers are mounted on castors for ease of movement. Upright freezers have feet that provide both a leveling feature and a locking feature to stop the freezer from rolling once it is in place. Chest freezers have locking front castors; locking front castors do not provide leveling adjustment, so the site chosen for the freezer must have a flat, level floor.

Position the freezer to allow disconnection to be made in respect to removal of the plug or appliance coupler, also the free air entry through the intake grill in the front and free air exit from the back. Provide a clearance of at least 150 mm (6 in) on all sides.

For efficient temperature control, the freezer should be placed in a shaded area, away from sources of excessive heat. For maximum cooling capability, the product should be located in an air-conditioned room.

#### 4.2.1 Occupancy rating (230 V, 50 Hz models only)

This equipment has a category A1 - B1 occupancy rating, with a refrigerant charge of less than 0.15 kg per sealed system.

Systems charged with less than 0.15 kg may be installed in any size room as long as adequate ventilation is provided, in order to remove rejected heat from the freezer and to vent any sudden loss of refrigerant in case of system failure.

#### 4.2.2 Below ground installations (230 V, 50 Hz models only)

We recommend allowing at least 18 m<sup>3</sup> (23.5 yd<sup>3</sup>) room volume for each freezer, to keep the air/refrigerant concentration from exceeding 20 % of the Lower Flammability Limit (LFL) in the event of a sudden loss of refrigerant into the room.

Basements and cellars must have adequate ventilation for the removal of heat rejected from the freezer(s).

## Installation

New Brunswick™ HEF® and G Freezers  
English (EN)

### 4.2.3 Installation categories (230 V, 50 Hz models only)

Category	Examples	Requirements
A1 (domestic/ public)	Hospitals Prisons Theaters Schools Supermarkets Hotels Dwellings	< 0.15 kg refrigerant per sealed system
B1 (commercial/ private)	Business or professional offices Shops Restaurants Laboratories General manufacturing	< 0.15 kg refrigerant per sealed system

### 4.3 Mains/Power plugs and receptacles

Eppendorf line of freezers are offered with a variety of mains/power cords to accommodate local voltage requirements. To determine the mains/power receptacle required in your lab, first identify the plug we provide from the list below and check the freezer rating plate for mains/power requirements, then see the table which follows.



#### NOTICE! Risk of material damage

- ▶ Only use approved mains/power cords with the correct power rating. Contact your local Eppendorf sales office for replacement cords.

- All 115 V, 60 Hz freezers use plug B, with the exception of Innova U101 freezers which use plug A
- All 208 - 230 V, 60 Hz freezers use plug C
- All 230 V, 50 Hz freezers are provided with both plugs D and E

Freezers with this Code	Have this Plug	Require this Receptacle	NEMA Reference	
			Plug	Receptacle
A			5-15P	5-15
B			5-20P	5-20
C			6-15P	6-15
<b>INTERNATIONAL</b>				
D			European (Schuko)	
E			UK Model	

#### 4.4 Requirements for water-cooled models

If your freezer has a water-cooled condenser, the following are water supply and drainage requirements:

Minimum flow requirements	3.8 L/min
Max inlet pressure	10 bars
Min inlet pressure	1 bar
Maximum supply temperature <sup>1</sup>	25 °C
Minimum supply temperature <sup>2</sup>	7.0 °C
Connection size	Inlet : 15 mm x 1/2" BSPT Outlet: 15 mm x 1/2" BSPT
Water quality	Water must be clean and free from particles that could cause blockage in the regulating valve or heat exchanger. A suitable inline strainer must be placed in the inlet pipe if there is any doubt about the cleanliness of the supply. The minimum filter requirement is 60 mesh 0.25 mm aperture.
Drainage requirements <sup>3</sup>	A recirculated cooler return line and a main supply line to the waste drain are required.
Typical Flow Rates	At a setpoint of -85 °C, an ambient temperature of 21 °C – 23 °C, and a water inlet temperature of 20 °C (see <i>Water flow rate on p. 23</i> ): 31 L/h for the U725-G.

<sup>1</sup>Water consumption will increase as water temperature increases.

<sup>2</sup>The condenser must never be allowed to freeze during operation. If, during normal cycling, water temperature approaches 6.0 °C, this must be checked.

<sup>3</sup>This installation requires checking the high stage discharge pressure and may require an adjustment of the water regulating valve; both operations MUST be carried out by a qualified engineer.



The minimum pressure differential requirement is 0.5 bar between water inlet and water outlet ports.

## Installation

New Brunswick™ HEF® and G Freezers  
English (EN)

### 4.5 Connecting multiple water-cooled freezers

- i** The water inlet pressure must always be higher than the water outlet pressure. The parallel connection method allows users to connect a large number of freezers as long as piping size is determined correctly to cope with required flow rate.
- i** It is recommended that a pressure regulator be used at the inlet of each freezer to monitor water pressure.

For water connection requirements, (see *Requirements for water-cooled models on p. 21*).

In order for the water-cooled freezer to operate correctly, one of the following installation setups will apply:

- Connecting freezers to a recirculating chiller
- Connecting freezers to the non-recirculating water supply (no chiller)

#### 4.5.1 Connecting freezers to a recirculating chiller

- i** The chiller must have appropriate cooling capacity.
- i** Never connect multiple freezers to a single water/chiller line in series; the temperature rise at the outlet from the first freezer makes it unsuitable to use for cooling of additional units.

To connect multiple freezers to a recirculating chiller to cool down ejected water to the required temperature of 25 °C or below, follow the setup below:

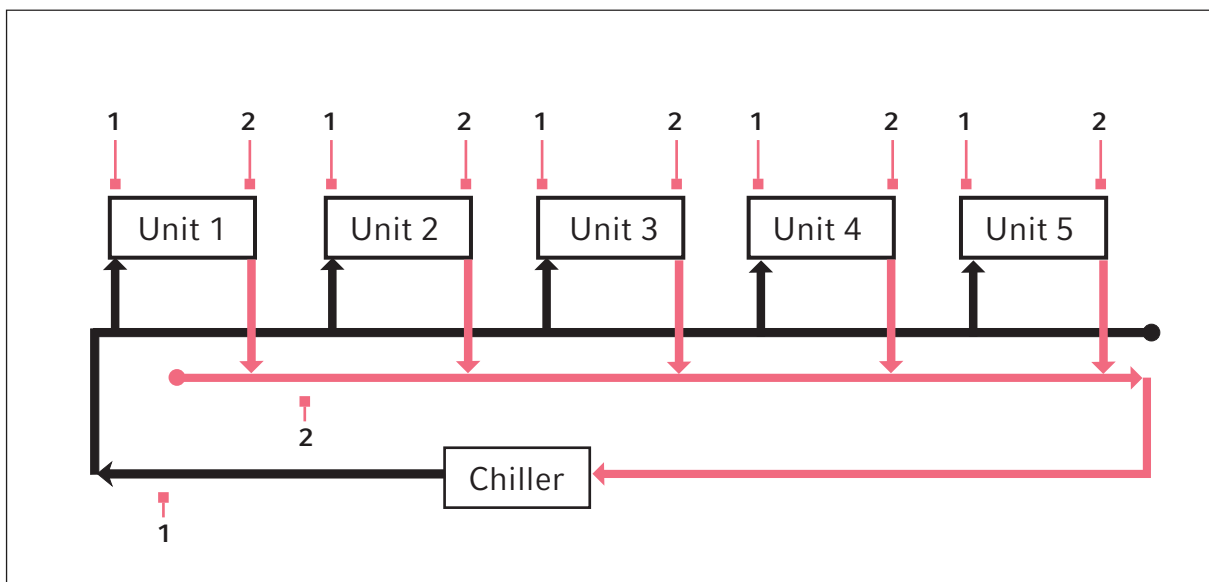

1 Inlet

2 Outlet

### 4.5.2 Connecting freezers to the non-recirculating water supply (no chiller)

To connect multiple freezers to the non-recirculating water supply without chiller, follow the setup below:

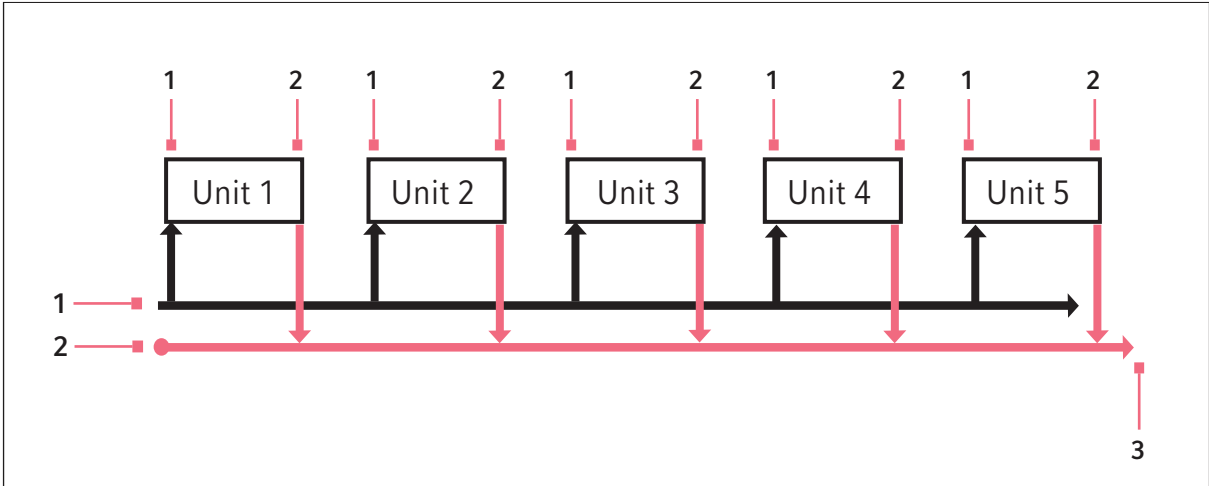

- 1 Inlet
- 2 Outlet
- 3 Drain

### 4.6 Water flow rate

This graph shows the typical water consumption when the freezer water regulating valve is fixed at the factory setting.\* The freezer is operating in normal stable conditions with no door openings.

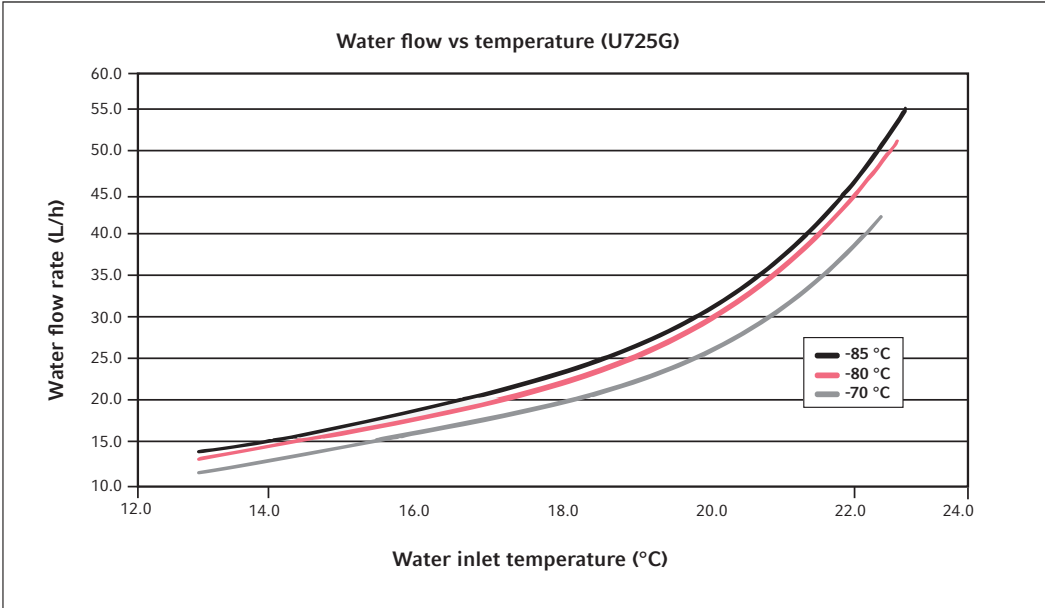

## Installation

New Brunswick™ HEF® and G Freezers  
English (EN)



\*Note: At the factory, the freezer is set up to have a 25 °C high stage refrigerant condensing temperature. This is the temperature that the refrigerant leaves the high stage condenser in our cascade system. Achieving this temperature is dependent on the flow of the water passing through the high stage condenser, which is controlled by the water regulating valve. The 25 °C high stage refrigerant condensing temperature was selected to provide the best balance between typical water temperatures used by our customers and energy efficiency.

### 4.7 Installing the shelves

Model U410 HEF and U570 HEF freezers are fitted with four adjustable shelves. Model U725 freezers are fitted with two adjustable shelves. These can be positioned in 12.7 mm (½ in) steps anywhere throughout the freezer.

To effectively utilize racks within the freezer, be sure to position them so that each shelf is aligned with the bottom of each inner door.

Perform the following steps to install the shelves:

1. Ensure that the freezer is turned off and unplugged.
2. Remove the protective plastic coating from the shelf.
3. Position the four shelf clips evenly within the freezer by squeezing the clip, then inserting it into the shelf support within the freezer.
4. Place the shelf in the freezer, making sure all four shelf clips are supporting the weight of the shelf.

To readjust the shelf or shelf clips, gently squeeze the shelf clip to release it from the side of the freezer, then reposition it as needed.

#### 4.7.1 Maximum freezer shelf load

U410 HEF	30 kg (66 lb)
U570 HEF	40 kg (88 lb)
U725 G	75 kg (165 lb)

### 4.8 Lockable freezer handle

Freezers are supplied with lockable handles.

The C660 HEF handle is fitted with a quarter turn key lock.

The upright freezer handle is fitted with barrel locks (push in and turn key to lock, turn key to unlock; the barrel will only lock when a key is turned to the lock position). The barrel lock may be removed from the upright freezer handle if the lock feature is not required.

An optional padlock adaptor can provide extra security by allowing the addition of a customer-supplied padlock to secure the freezer handle.

#### 4.8.0.1 Removing the upright freezer handle barrel lock

Perform the following steps to remove the barrel lock from the upright freezer handle, if the lock feature is not required:

1. Open the freezer door and place the freezer handle in closed position.
2. Remove the two screws from behind the lock barrel.

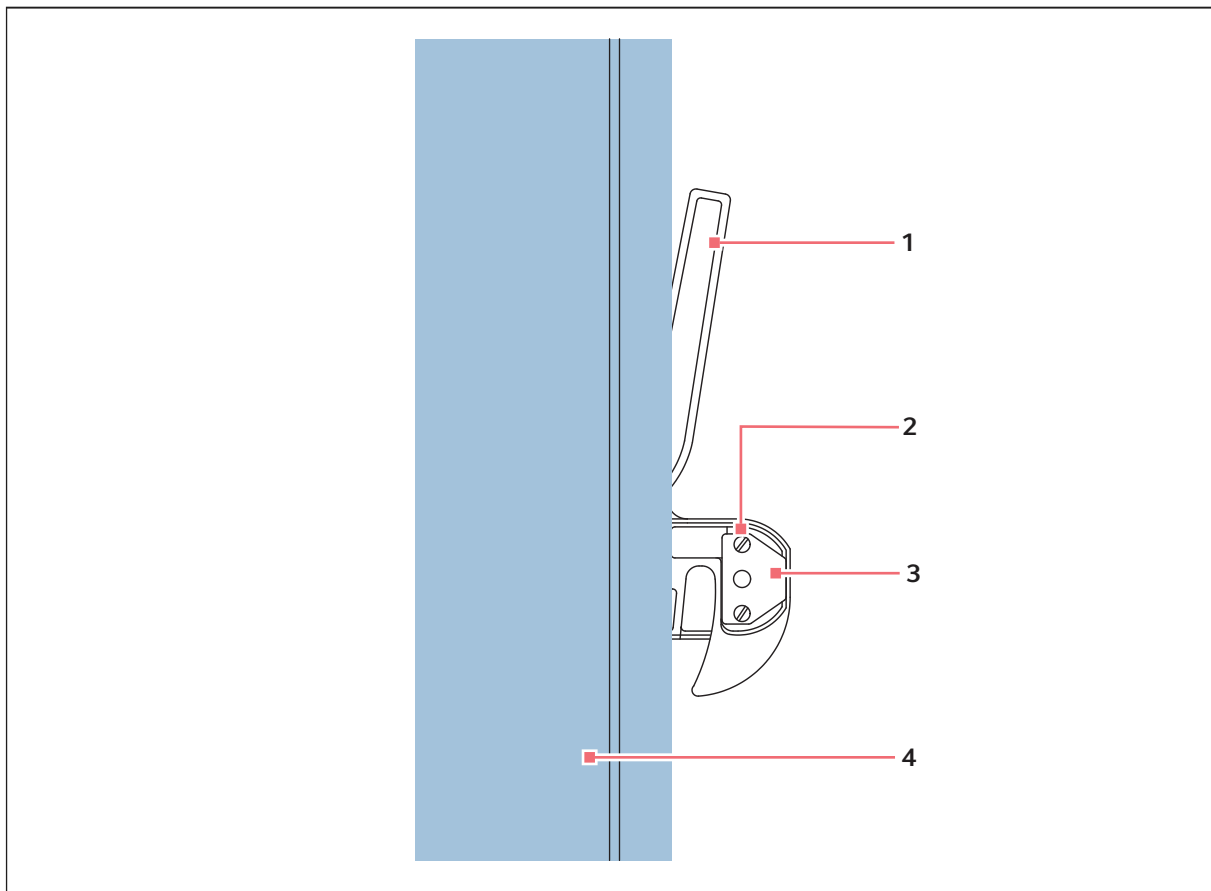

**1 Freezer handle**

**2 Screw (1 of 2)**

**3 Lining plate**

**4 Freezer door wall**

3. Remove the lining plate and lock barrel.
4. Insert the plastic blanking plug supplied.
5. Insert the lining plate and screw in the two screws.

**Installation**

New Brunswick™ HEF® and G Freezers  
English (EN)



It is important that the handle lock lining plate be installed at all times.

---

**NOTICE! Risk of material damage**

▶ DO NOT SLAM THE DOOR WITH THE HANDLE IN THE CLOSED POSITION.

---

6. Place freezer handle in open position and close freezer door.

The door handle has a cam action to pull the door closed and a reverse cam action to break the seal so the door can be opened. When closing the outer door, ensure that the cam is engaged for correct operation. The initial vacuum inside the cabinet may cause the door to appear closed, but when the vacuum releases, the door will open. Always ensure the handle is properly engaged. It is important that the heated vent port is kept clear. This will avoid putting undue stress on the handle mechanism.

## 5 Operating controls and function

### 5.1 Controls and function

Operating controls are located on a control panel mounted in the door of the upright freezers, and on the console on the right side of chest freezers.

Eppendorf line of freezers are equipped with S.M.A.R.T. Plus™ diagnostic software, to help identify the cause of a fault or setpoint variance.

This section describes the controls and function of the control panel, (see Fig. 5-1 on p. 27).

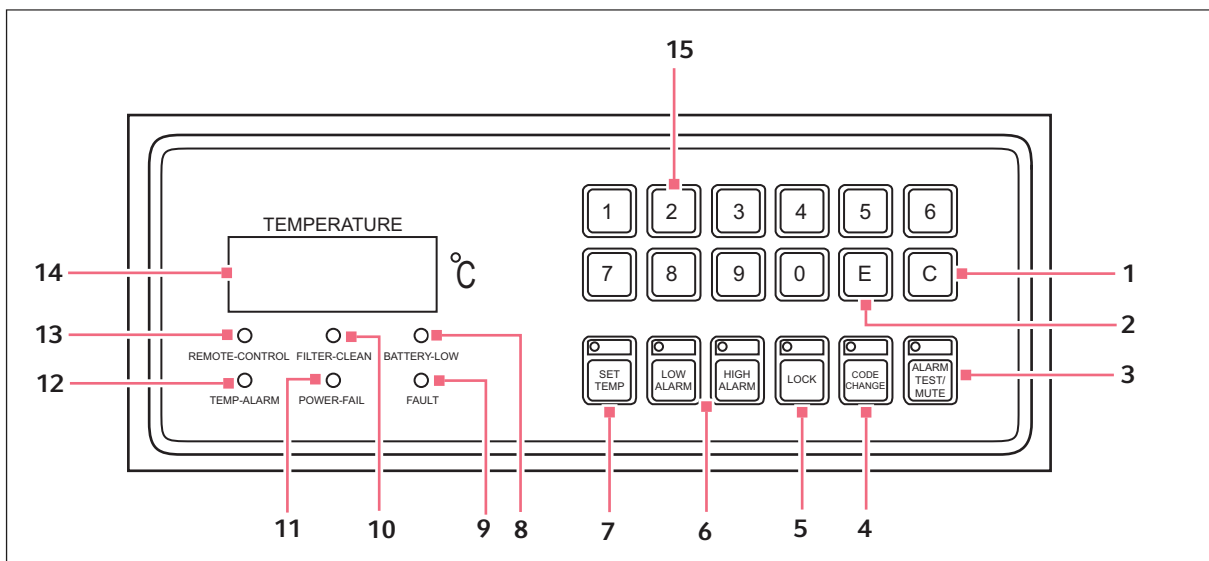

Fig. 5-1: Display panel and keypad

#### 5.1.0.1 "C" key

Operation in normal mode with **LOCK** lamp off.

Item	Name	Function
1	C	Used to cancel data when programming.

#### 5.1.0.2 "E" key

Operation in normal mode with **LOCK** lamp off.

Item	Name	Function
2	E	Used to enter data when programming.

## Operating controls and function

New Brunswick™ HEF® and G Freezers  
English (EN)

### 5.1.0.3 Alarm test/mute key

Operation in normal mode with **LOCK** lamp off.

Item	Name	Function
3	<b>ALARM TEST/ MUTE</b>	Sounds the audible alarm. If the audible alarm is on due to a fault condition, press this key to silence the alarm. The lamp LED lights can also be tested by pressing this key. The lights should all illuminate and the display should read "8888".

### 5.1.0.4 Code change key

Operation in normal mode with **LOCK** lamp off.

Item	Name	Function
4	<b>CODE CHANGE</b>	Used to change freezer lock codes. Inactive in normal mode.

### 5.1.0.5 Lock key

Operation in normal mode with **LOCK** lamp off.

Item	Name	Function
5	<b>LOCK</b>	Locks and unlocks the control panel for programming sequence.

### 5.1.0.6 High alarm/low alarm

Item	Name	Function
6 & 12	<b>[HIGH/LOW] TEMP-ALARM</b>	The <b>TEMP-ALARM</b> illuminates and the audible alarm sounds if the freezer's internal temperature is above/below the user-selected alarm setpoints. The <b>LED</b> illuminates as soon as the setpoint is passed. The high temperature audible alarm has a programmable delay (see <i>Setting the alarm delay on p. 36</i> ). After the temperature returns to the normal range, the <b>TEMP-ALARM</b> switches off and the audible warning stops.



The audible alarm can be silenced by pressing the **ALARM TEST/MUTE KEY**. If the temperature has not returned to normal range after the programmed time period, the audible warning will sound again. This pattern will continue to repeat until the temperature returns to normal.

### 5.1.0.7 High alarm/low alarm keys

Operation in normal mode with **LOCK** lamp off.

Item	Name	Function
6	<b>HIGH-ALARM</b>	Displays current high alarm temperature setting.
6	<b>LOW-ALARM</b>	Displays current low alarm temperature setting.

### 5.1.0.8 Temp-alarm light

Item	Name	Function
12	<b>TEMP-ALARM</b>	Should a mains/power failure cause the temperature to surpass the alarm setpoint, the <b>TEMP-ALARM</b> illuminates. (The audible alarm will already be sounding due to the mains/power failure). The <b>TEMP-ALARM</b> lamp will extinguish when the temperature returns to normal set range. Cancel the <b>TEMP-ALARM</b> by pressing the <b>ALARM TEST/MUTE KEY</b> .

### 5.1.0.9 Set temp key

Operation in normal mode with **LOCK** lamp off.

Item	Name	Function
7	<b>SET TEMP</b>	Displays current temperature setting. Used to change temperature settings.

### 5.1.0.10 Battery low light

Item	Name	Function
8	<b>BATTERY-LOW</b>	With mains/power <b>ON</b> : illuminates if battery voltage is below 5.6 V, starts flashing when voltage drops below 5 volts. With mains/power <b>OFF</b> : if battery voltage drop below 5.5 V, this fault indicator will stop functioning.

### 5.1.0.11 Fault light

Item	Name	Function
9	<b>FAULT</b>	Illuminates if there is a system failure within the freezer. Interfacing with the S.M.A.R.T. Plus™ diagnostics via the control panel, the fault can be determined (see <i>Error messages on p. 51</i> ). System failure is accompanied by an audible alarm. Correction of the fault extinguishes the light and audible alarm.

## Operating controls and function

New Brunswick™ HEF® and G Freezers  
English (EN)

### 5.1.0.12 Filter clean light

Item	Name	Function
10	<b>FILTER-CLEAN</b>	Illuminates, accompanied by an audible alarm, to indicate a blocked or dirty filter. Filter is located on the front at the bottom of all freezers. Remove by turning the two thumbscrews on the filter holder ¼ turn. Clean filter by washing in mildly soapy water, then air dry. If filter warning light does not go out after replacing the cleaned filter, contact your local Eppendorf service representative.

### 5.1.0.13 Power fail light

Item	Name	Function
11	<b>POWER-FAIL</b>	Illuminates if the mains/power supply fails, flashing at approximately 10-second intervals, accompanied by an audible alarm. When mains/power is restored, the indicator goes off and the audible alarm stops. (The battery must be switched on and charged for this indicator to operate.)

### 5.1.0.14 Remote control light

Item	Name	Function
13	<b>REMOTE/ CONTROL</b>	Indicates when freezer is operating under remote computer control via the optional RS-485 interface port and BioCommand® SFI software, or other laboratory data logging software.



The keypad controls are locked when the freezer is under remote control.

### 5.1.0.15 Temperature °C display

Item	Name	Function
14	<b>TEMPERATURE °C</b>	The digital display normally shows the current internal temperature of the freezer. Temperature is displayed in 1 °C increments.

### 5.1.0.16 Numerical keys

Operation in normal mode with **LOCK** lamp off.

Item	Name	Function
15	<b>NUMERICAL KEYS (1-0)</b>	Used to input data when programming. Keys 8 and 9 are also used to program alarm delays (see <i>Setting the alarm delay on p. 36</i> ).

## 6 Operation

### 6.1 Getting started

---



#### **WARNING! Risk of personal injury**

- ▶ BEFORE connecting the freezer to the mains/power supply, make sure that the mains/power supply matches the requirements of the equipment. Check the specification plate (located on the side of the freezer) for the electrical requirements. The equipment should be connected to an earth/grounded socket.
- 

#### 6.1.1 Plug in

Once you have verified that the mains/power supply matches the electrical requirements of the freezer, connect the product to the mains/power supply using the mains/power cord provided.

---



#### **WARNING! Risk of personal injury**

- ▶ If the freezer's voltage rating does not match your mains/power supply, or if the plug on the mains/power cord does not fit the outlet, do not plug the freezer in.
  - ▶ Contact your laboratory supervisor, safety officer, or qualified service or electrical engineer.
- 



#### **NOTICE! Risk of material damage**

- ▶ Some freezers are supplied with more than one removable mains/power cord. Utilize the cord that matches your power socket. Check the voltage rating plate on the side of the freezer, to confirm that the freezer is compatible with your laboratory mains/power supply.
- 

#### 6.1.2 Turning the freezer On/Off

---



#### **WARNING! Risk of personal injury**

- ▶ The On/Off circuit breaker and battery switch are fitted with IP65 plastic covers, to prevent a possible source of ignition. These covers must not be removed. If one of the covers needs to be replaced, the replacement must be performed by a qualified and authorized person. Failure to observe this safety warning could result in a dangerous situation in the event of a failure.
- 

The **ON/OFF** circuit breaker is located within the lockable panel at the bottom right-hand corner of the upright freezer or to the left of the control panel on the chest model.

**Operation**

New Brunswick™ HEF® and G Freezers  
English (EN)

To remove the lockable panel and turn the circuit breaker and battery switch On/Off:

1. Insert and turn the key (provided) one quarter turn to the right.



The key can be removed to prevent access.

2. Remove the panel.
3. Set the **ON/OFF** circuit breaker and battery switch to the **I (ON)** position.

The temperature display illuminates immediately.

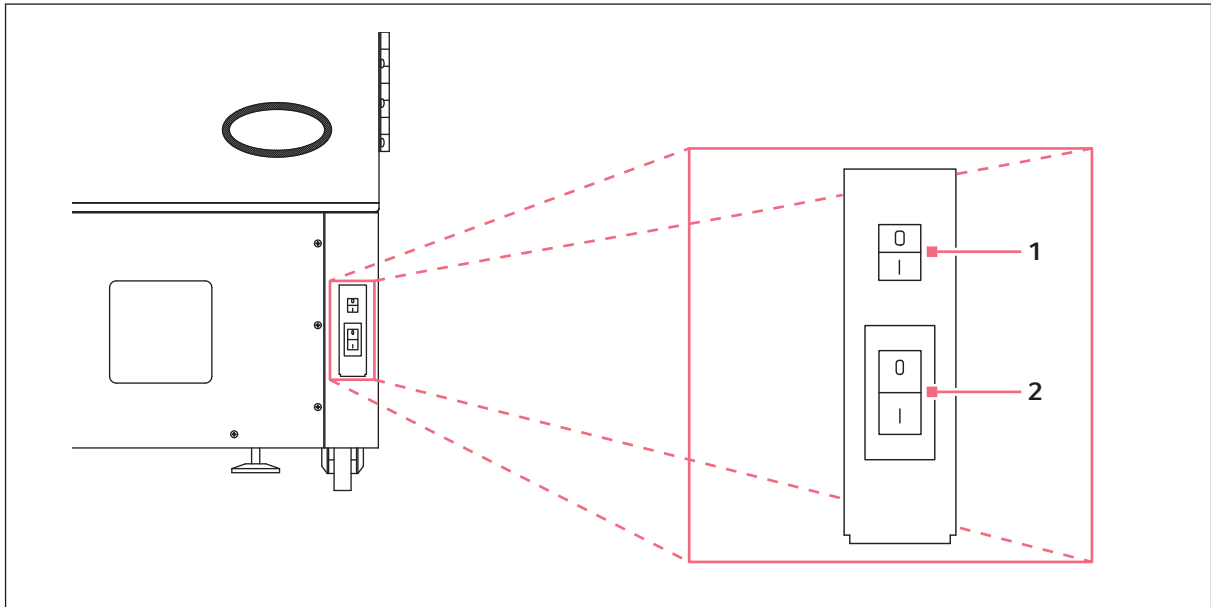

Fig. 6-1: Upright freezers switch location

**1 Battery switch**

**2 On/Off circuit breaker switch**

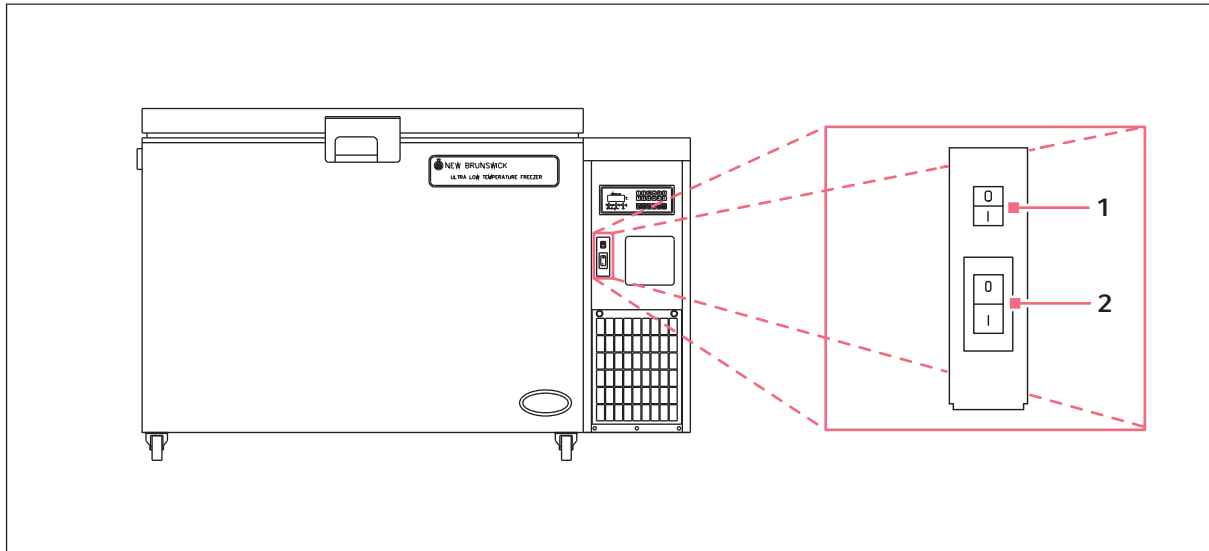

Fig. 6-2: Chest freezers switch location

### 1 Battery switch

### 2 On/Off circuit breaker switch

- i The compressors will not operate for approximately 3 min after connection of the mains/ power supply, because there is an automatic delay device in the circuit. Temperature and alarm settings can be adjusted immediately.

### 6.1.3 Alarm/battery activation

The equipment is delivered with the battery deactivated. The Power Fail alarm is activated by the battery rocker switch within the lockable panel, which is located at the bottom right-hand corner. The switch is labelled **I (ON)** and **O (OFF)** (see Fig. 6-1 on p. 32) and (Fig. 6-2 on p. 33).

- ▶ To activate the alarm, place the battery switch in the **I** position.
- i Failure to turn on the battery switch may lead to a discharged battery, low battery alarm indication, and/or a disabled alarm system.
- ▶ After activating the alarm, test its operation by pressing the **ALARM TEST/MUTE** key on the display. The audible alarm should sound.

The **ALARM TEST/MUTE** key also tests the LED lamps. All of the LEDs should light up together when the button is pressed.

- i Pull down time to  $-86\text{ }^{\circ}\text{C}$  will be dependent on the freezer size and model. The alarm will sound every 30 min until the temperature setpoint is reached. Use the **ALARM TEST/MUTE** key to mute the alarm during this initial pull-down period.

If the freezer is turned off during the initial pull-down period, the alarm will activate 30 min after switching it back on.

## Operation

New Brunswick™ HEF® and G Freezers  
English (EN)

The factory-set temperature is -80°C.

### 6.1.4 Testing the alarm monitoring socket

The freezer is fitted with a remote alarm socket for testing power-fail and low battery alarms, and for connection to an external building monitoring system or optional auto-dialer, (see *Alarm monitoring socket on p. 39*). To test the alarm monitoring socket.

- ▶ Turn off (O) the **ON/OFF** circuit breaker.

This will test the **POWER FAIL** and **ALARM** output at the same time.

The battery must be switched on to test the **POWER FAIL**. The remote alarm facility provides voltage-free contacts rated at 1 A, 24 V maximum.

### 6.1.5 Vacuum effect

After closing the freezer door, a vacuum may be created. Before the door can be opened again, it may be necessary to wait 2 or 3 min for the vacuum to be released by the vent port. **Do not try to force the door.** During the release of the vacuum, a slight hissing may be heard. In order to minimize vacuum formation, the vent heater assembly has a spring-loaded plunger to clear ice from the inside of the vent.



Be careful not to place a rack directly against the vent, as this will inhibit the plunger's ability to operate correctly (see *Heated vent port on p. 43*).

## 6.2 Programming the freezer

Set the freezer to any temperature within the range from -50 °C to -86 °C.



All temperature setpoints are automatically negative °C.

### 6.2.1 Setting operating temperature

To set the operating temperature for the freezer:

1. Press the **LOCK** key.



The **LOCK** lamp will flash if a lock code (password protection) is required, (see *Changing lock codes on p. 37*).

The **LOCK** lamp will illuminate, indicating the system is unlocked and parameters can be changed.

2. Press the **SET TEMP** key.

Its indicator will flash and the display will indicate 0.

3. Using the numerical keys, enter a new temperature (from -50 °C to -86 °C).

The temperature selected will appear in the **TEMPERATURE** display.

4. When the correct temperature is displayed, press the **E** key to enter the data. To set the high alarm setpoint skip to (see *Setting high alarm setpoint on p. 35*), step 2.

The **SET TEMP** lamp will go off.

5. Press the **LOCK** key to exit programming.

The **LOCK** lamp will go off and the freezer will return to normal mode.



Press the **C** key to clear the display during programming.

## 6.2.2 Setting high alarm setpoint

The high alarm setpoint may not be warmer than -10 °C and may not be less than within +5 °C of the operating temperature. The default setting is +5 °C from the temperature setpoint.

1. Press the **LOCK** key.



The **LOCK** lamp will flash if a lock code (password protection) is required, (see *Changing lock codes on p. 37*).

The **LOCK** lamp will illuminate, indicating the system is unlocked and parameters can be changed.

2. Press the **HIGH ALARM** key.

Its indicator will flash and the display will indicate 0.

3. Using the numerical keys, enter a new alarm setpoint temperature.

The selected temperature will appear in the **TEMPERATURE** display.

4. When the correct temperature is displayed, press the **E** (Enter) key to enter the data. To set the low alarm setpoint skip to (see *Setting low alarm setpoint on p. 35*), step 2.

The **HIGH ALARM** indicator will turn off.

5. Press the **LOCK** key to exit programming.

The **LOCK** lamp will go off and the freezer will return to normal mode.



Press the **C** key to clear the display during programming.

## 6.2.3 Setting low alarm setpoint

The low alarm setpoint may not be colder than -91 °C and may not be more than within -5 °C of the operating temperature. The default setting is -5 °C from the temperature setpoint.

1. Press the **LOCK** key.



The **LOCK** lamp will flash if a lock code (password protection) is required, (see *Changing lock codes on p. 37*).

The **LOCK** lamp will illuminate, indicating the system is unlocked and parameters can be changed.

2. Press the **LOW ALARM** key.

Its indicator will flash and the display will indicate 0.

3. Using the numerical keys, enter a new alarm setpoint temperature.

## Operation

New Brunswick™ HEF® and G Freezers  
English (EN)

The selected temperature will appear in the **TEMPERATURE** display.

- When the correct temperature is displayed, press the **E** (Enter) key to enter the data.

The **LOW ALARM** indicator will turn off.

- Press the **LOCK** key to exit programming.

The **LOCK** lamp will go off and the freezer will return to normal mode.



Press the **C** key to clear the display during programming.

### 6.2.4 Checking temperature and alarm setpoint settings

To view the currently set operating temperature, high alarm setpoint, or low alarm setpoint for the freezer.

- Press the **SET TEMP** key, **HIGH ALARM** key, or the **LOW ALARM** key and read the display.



If you press the **SET TEMP**, **HIGH ALARM** or **LOW ALARM** key while the **LOCK** key lamp is flashing, the display will read ----, which indicates that the freezer is locked.

### 6.2.5 Setting the alarm delay

The **HIGH ALARM** audible alarm and the **REMOTE ALARM** monitoring socket can be programmed to a time delay set between 0 and 40 minutes.

The default time delay is 30 minutes. If the time delay is set to 0 minutes, the system will program it as 15 seconds.



Press **KEY 8** to display the High Temperature audible alarm delay, and press **KEY 9** to display the Remote Alarm Socket switching delay.

To set the audible **HIGH ALARM** delay (**KEY 8**):

- Press the **LOCK** key.  
The **LOCK** lamp illuminates, indicating the system is unlocked and parameters can be changed.
- Press keypad button **8**.  
**pp** flashes on the display.
- Enter the desired value (e.g., press keypad buttons **1** and **0** to designate 10 minutes).
- Press the **E** (Enter) key.  
The **LOCK** lamp goes out.

To set the **REMOTE ALARM** socket time delay (**KEY 9**):

- Press the **LOCK** key.  
The **LOCK** lamp illuminate, indicating the system is unlocked and parameters can be changed.
- Press keypad button **9**.  
**pp** flashes on the display.

3. Enter the desired value (e.g., press keypad button **5** to designate 5 minutes).
4. Press the **E** (Enter) key.

The **LOCK** lamp goes out.

If the number entered is valid, --- flashes on the display, the value has been stored, and the **LOCK** lamp goes out. (This is a one-shot operation.)

If the number entered is out of range, **-EE-** shows on the display and the operation will need to be repeated using a valid number.

### 6.2.6 Changing lock codes



If you enter a lock code when there is none, or if you replace an existing lock code with a new one, take note of the new code before you enter it.

If the code is forgotten, you will need to contact Customer Service to regain access to the programming mode of the freezer.

The freezer is delivered unlocked. To change the code, the freezer must be unlocked. If a lock code has already been set (indicated by the **LOCK** lamp flashing when the **LOCK** key is pressed), that same code must be entered to unlock the freezer. When the freezer is unlocked, the **LOCK** lamp is on (not flashing).

Once the freezer is unlocked, follow these steps to set a new lock code:

1. Press the **CODE CHANGE** key.  
The lamp will flash and the display will go blank.
2. Using the numerical keys, enter the new four-digit number. Check it on the display.
3. Press the **C** key to cancel the entry if the display shows it to be incorrect, then enter the correct number.
4. When the number is correct, record the new number somewhere secure. Then press the **E** (Enter) key.  
The **CODE CHANGE** indicator will turn off.
5. Press the **LOCK** key.  
Its indicator lamp will turn off.

The freezer now has a new lock code. If at any time you wish to change this code, you will have to enter this code to unlock the system before you can enter a new code.

Setting the lock code to **0000** disables the lock completely. With the **0000** code, you would need only press the **LOCK** key to reprogram the freezer.

### 6.2.7 Setting the temperature offset

The temperature offset function enables to add a temperature offset to the factory defined temperature settings.

1. Press the **LOCK** Key.
2. Press the **C** key to access the offset function.

## Operation

New Brunswick™ HEF® and G Freezers  
English (EN)

3. Press **0**, **1**, **2**, **3**, or **4** key to set the offset in degrees.
4. Press the **ENTER** key to confirm selection.



Set temperature offset to "0" for no offset.

### 6.3 Battery backup switch

This is a rocker switch labeled **I/O** behind the locked front panel. In the **O** position, the battery is disconnected. This position should only be used while in transit, in storage, or to change the battery.

At all other times the switch should be kept in the **I** position for the battery to be charged, and for the alarm function to be available in the event of mains/power failure. **(Failure to set the switch may result in impaired battery life, and the alarm will not trigger if the mains/power fails.)**

With the battery switch on, during a mains/power failure, the internal freezer temperature will be displayed at ten-second intervals, and the audio alarm will also sound. The audible alarm may be muted by pressing the **ALARM TEST/MUTE** key on the control panel, but will sound again after 30 minutes if the fault has not been corrected. Pressing the same button again will mute the alarm for an additional 30 minutes; the pattern will continue to repeat until the initial problem is corrected.

### 6.4 RS-485 Connection



---

#### **NOTICE! Risk of material damage**

- ▶ RS-485 Interface external device shall secure double/reinforced insulation from mains voltage (according to 61010-1).
- 

An optional serial I/O connection rated 5 V max for RS-485 connection can be fitted. Contact your local Eppendorf distributor for details.

## 6.5 Alarm monitoring socket

The freezers are provided with an alarm monitoring socket at the rear of the freezer and a matching plug for external monitoring. This plug can be connected either to a central monitoring system such as a building management system, or to a remote alarm via an auto-dialer.

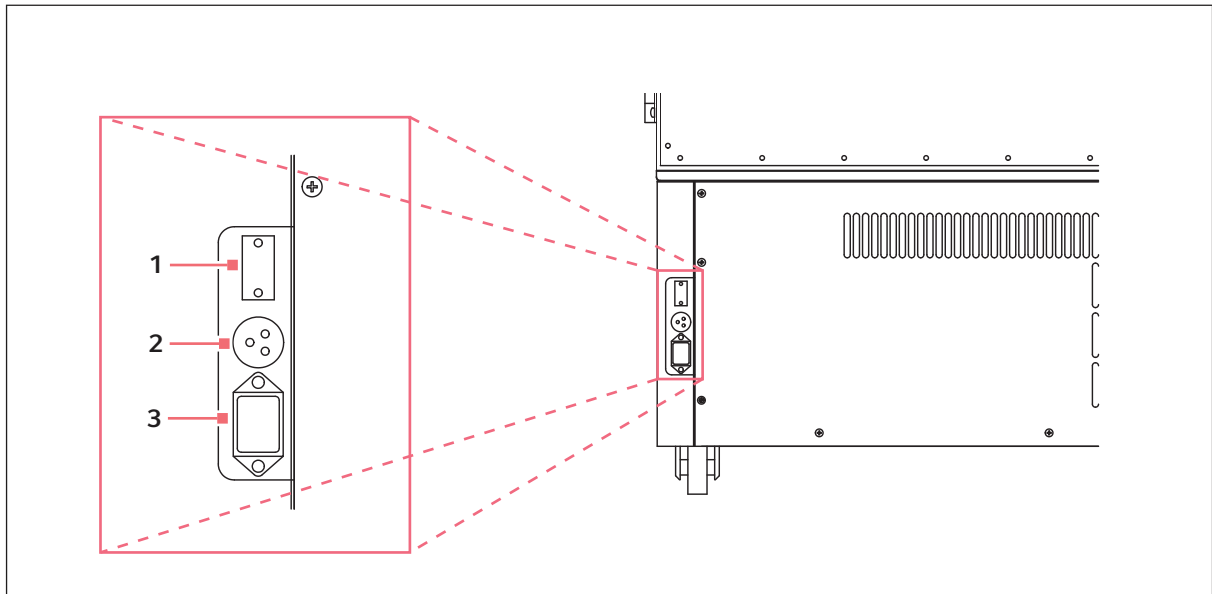

Fig. 6-3: Upright freezers alarm monitoring socket

1 RS-485 connector (optional)

3 Mains/power socket

2 Alarm monitoring socket

**Operation**

New Brunswick™ HEF® and G Freezers  
English (EN)

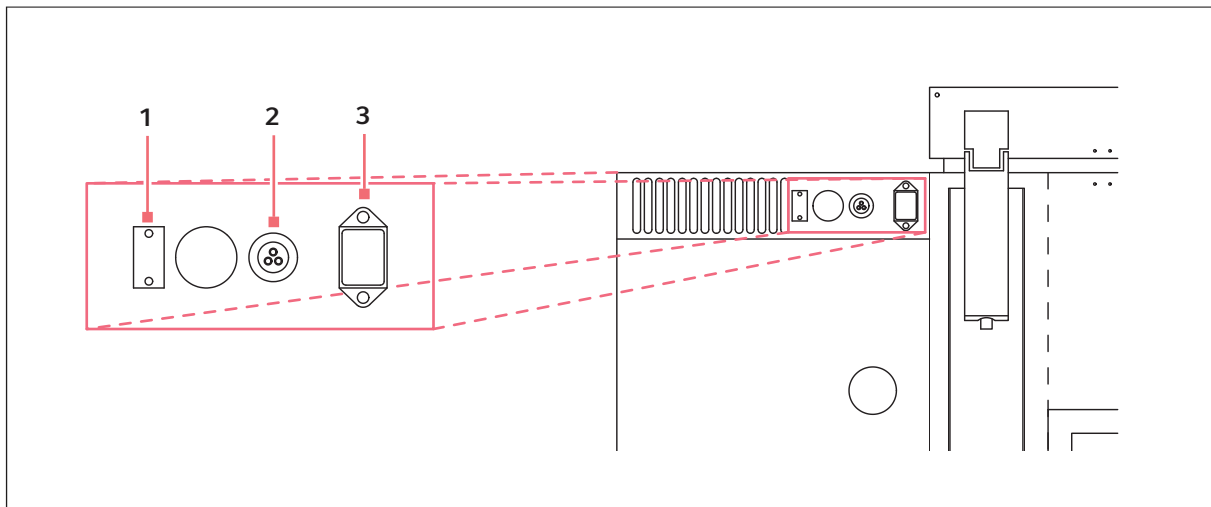

Fig. 6-4: Chest freezers alarm monitoring socket

**1 RS-485 connector (optional)**

**3 Mains/power socket**

**2 Alarm monitoring socket**

The configuration of the socket is shown in (Fig. 6-5 on p. 40) and (Fig. 6-6 on p. 41), as viewed from the rear of the freezer. Within the freezer, the socket is connected to voltage-free contacts rated at 24 volts, 1 amp. In normal operation, with the mains/power on, pin 1 is connected to pin 2 (N/C), and in the alarm condition, with mains/power off, pin 1 is connected to pin 3.

The High Temperature Alarm output to the Remote Alarm Monitoring Socket can be programmed to a set time delay (see *Setting the alarm delay* on p. 36).



**NOTICE! Risk of material damage**

- ▶ Hazardous voltages must not be connected to the remote alarm socket. Max Rating 24 V 1 A.

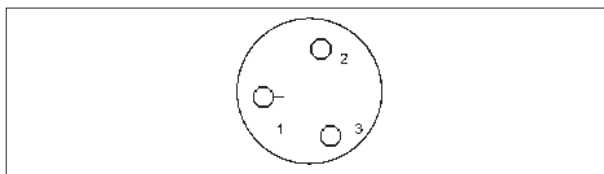

Fig. 6-5: Remote alarm socket - upright freezer

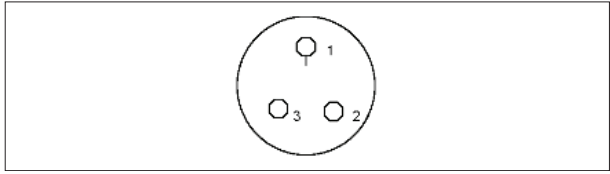

Fig. 6-6: Remote alarm socket - chest freezer

**Operation**

New Brunswick™ HEF® and G Freezers  
English (EN)

## 7 Maintenance

### 7.1 Cleaning

---



#### NOTICE! Risk of material damage

- ▶ Maintenance, adjustment and repair work should be carried out only by QUALIFIED, EXPERIENCED personnel who have been AUTHORIZED to undertake such work by Eppendorf or its authorized agents.
- 

#### 7.1.1 Painted surfaces

All exterior paint work and inner doors should be cleaned using a solution of mild detergent in water. **Do not use abrasive cleaners or solvents.**

#### 7.1.2 Interior and shelves

The interior panels and shelves are made of stainless steel. They may be cleaned using a recommended cleaning solvent, 70 % Isopropyl alcohol 30 % distilled water applied with a lint free cloth.

#### 7.1.3 Air intake grill and filter

---



#### NOTICE! Risk of material damage

- ▶ Serious damage to the freezer may result if the air intake is blocked. Check that there is no obstruction of the airflow to the freezer. The air intake filter must also be cleaned regularly.
  - ▶ Remove the filter from behind the grill by turning the thumbscrews ¼ turn and opening grill downward. The filter should be washed in warm soapy water and left to air dry before replacing.
- 

The air intake grill must be cleaned regularly to keep it free from dust and debris. Under normal conditions, clean the grill once every three months. If the area around the freezer is very dusty or dirty, clean the grill more often.

- ▶ Brush the grill with a soft brush and, if a vacuum cleaner is available, vacuum the dust from the grill.

#### 7.1.4 Heated vent port



There is an electrically-heated vent port in the freezer which must not be allowed to become blocked or sealed off.

Over a period of a few weeks, depending on how often the freezer is being used, a small mushroom of ice will form around the end of the vent port. If the vent port is allowed to become blocked, a vacuum will be

**Maintenance**

New Brunswick™ HEF® and G Freezers  
English (EN)

created when the door is closed. It will not be possible to open the door or lift the lid until the vacuum has leaked away through the seal, which can take up to two hours due to the high quality of the seals.

The vent port is located on the left-hand side of the freezers.

- ▶ If the door cannot be opened, clear the vent port by pressing the manual plunger on the outside of the air vent.

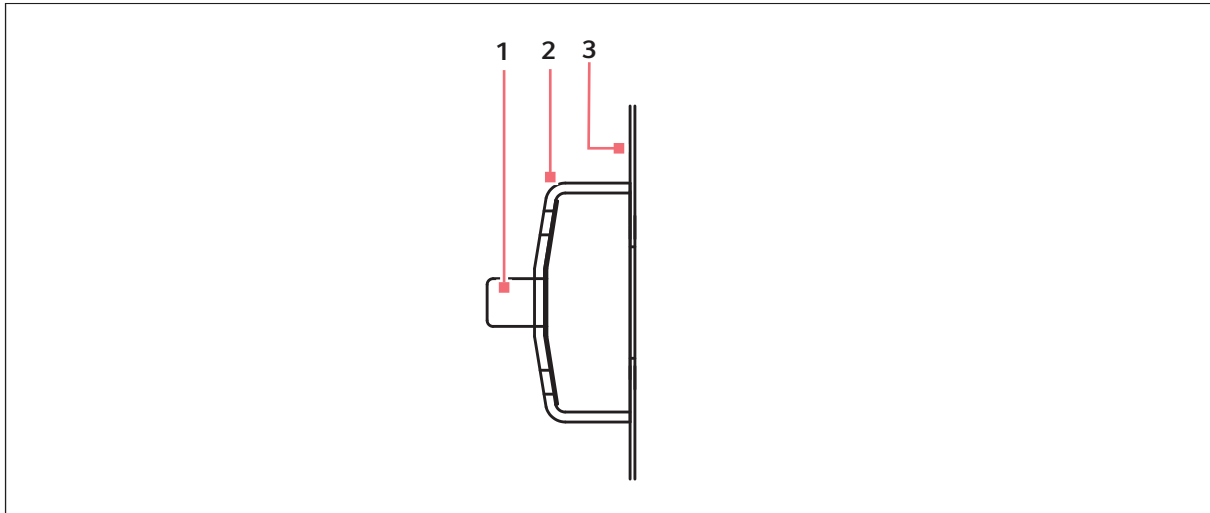

**1 Plunger**

**3 Freezer outer wall**

**2 Cover**

### 7.1.5 Door or lid seal

Be sure to treat the door or lid seal with care. Avoid damaging this seal in any way. The freezer cannot operate properly with a defective seal.

- ▶ It is advisable to wipe both the seal and the surface against which it seals with a soft dry cloth once a month.

## 7.2 Routine maintenance

---



### NOTICE! Risk of material damage

- ▶ Maintenance, adjustment and repair work should be carried out only by QUALIFIED, EXPERIENCED personnel who have been AUTHORIZED to undertake such work by Eppendorf or its authorized agents.
- 

### 7.2.1 Lubrication

Every 12 months the outer door hinges and the handle mechanism should be *lightly* lubricated using general-purpose oil or spray grease.

### 7.2.2 Defrosting

After an extended period of operation, defrosting may become necessary:



### NOTICE! Risk of material damage

- ▶ Do not attempt to chip or scrape the ice with a sharp instrument. Allow the ice to melt naturally.
- 

1. De-activate the alarm by switching the battery (alarm) switch (located behind the lockable panel on the front of the freezer) to off (O).
2. Unplug the freezer from the mains/power supply.
3. Leave the inner and outer doors or lids open.
4. Allow the accumulated ice to melt.
5. Mop up the resulting water.
6. Dry and decontaminate the interior of the freezer.
7. When defrosting is complete, reconnect the freezer to the mains/power supply.
8. Turn the mains/power switch on (I) and re-activate the battery (alarm) switch.

### 7.2.3 Removing the inner doors (upright models)

To remove the inner doors:

1. Fully open the outer door of the freezer.
2. Fully open the inner door.
3. Lift off inner door from hinges and set aside.

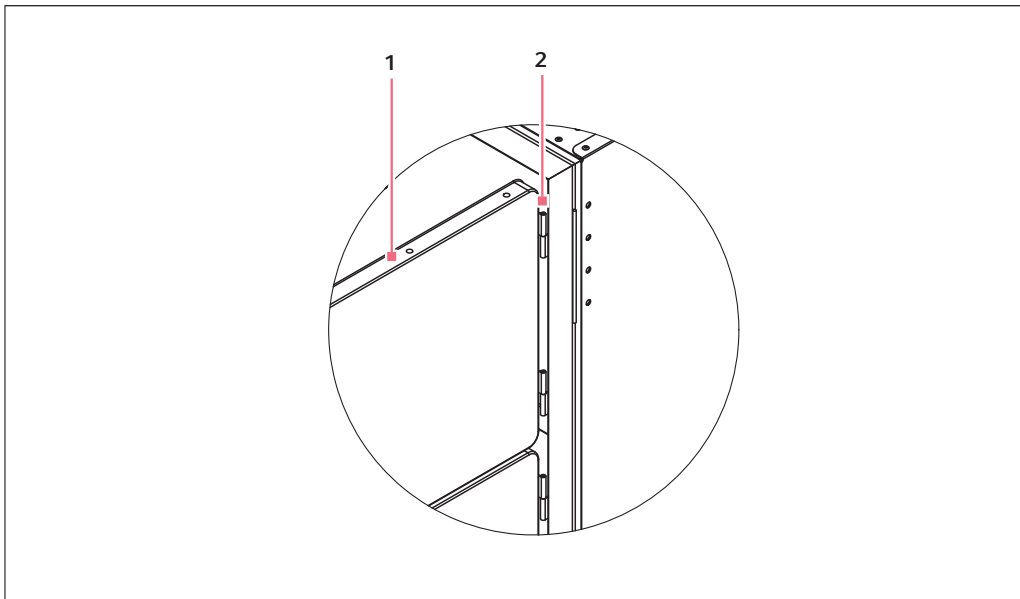

Fig. 7-1: Lift-off inner door

#### 1 Inner door

#### 2 Lift-off hinge

Repeat procedure for each door.

### 7.2.4 Replacing the inner door (U725-G)

To replace the inner door of the U725-G freezer:

1. Fully open the outer door of the freezer.
2. Fit door to hinge pins and close.
3. Check to ensure that inner door gasket is sealing against the freezer trim.
4. If required, adjust the latch retainer by loosening the screws and moving forward or backwards.
5. Close outer door.

### 7.2.5 Replacing the inner door (Premium HEF upright models)

To replace the inner door of the premium HEF upright freezer:

1. Fully open outer door of the freezer.
2. Fit each door to hinge pins and close.
3. Close outer door.



No adjustment should be necessary.

## 7.2.6 Electrical components

---



### **WARNING! Risk of personal injury**

- ▶ All electrical components that could cause possible ignition of refrigerant vapor during normal operation have been enclosed in an IP65 enclosure.
  - ▶ During routine maintenance, care must be taken to avoid any damage to the gaskets and sealing grommets of these enclosures; also check the gaskets and sealing grommets routinely to ensure their integrity. Should any damage or deformity be detected, the gasket and/or sealing grommet must be replaced immediately.
  - ▶ Failure to observe this safety warning could result in a dangerous situation.
- 

### 7.2.6.1 Lamps

Regularly check the indicator lamps:

- ▶ Press the **ALARM TEST/MUTE** key.  
All of the indicator lamps should illuminate, and the display should read **8888**.

### 7.2.6.2 Alarms

Regularly check the alarm:

- ▶ Press the **ALARM TEST/MUTE** key.  
The **TEMP** indicator should illuminate and the audible alarm should sound.

### 7.2.6.3 Battery replacement

---



### **NOTICE! Risk of material damage**

- ▶ Do not remove panels. There are no user controls behind any panels.



### **NOTICE! Risk of material damage**

- ▶ Use only a replacement battery of the correct type and part number.
  - ▶ The battery must be fitted so the terminals correspond to the polarity labels on the electrical panel.
-

**Maintenance**

New Brunswick™ HEF® and G Freezers  
English (EN)

The YUASA–NP6 V 2.8 Ah battery is mounted on the electrical panel. This is located behind the right-hand base cover.

To replace the battery:

1. Switch off the mains/power switch and disconnect the mains/power supply.
2. Remove the side cover and the battery clamp securing the battery to the electrical panel.
3. Disconnect the battery terminals.
4. Install the new battery, fixing screws, and the side cover.



Be certain, when reconnecting the battery, to respect the correct polarity (red is + positive and black is – negative).

5. Reconnect the freezer to the mains/power supply and turn the mains/power switch on (I).

#### 7.2.6.4 Fuses

Fuses must be replaced by an Eppendorf approved service engineer. Contact Eppendorf Service.

### 7.3 Service safety checklist

**NOTICE! Risk of damage to equipment**

- ▶ Please fill in the following form before servicing. This form must be handed to service engineer to keep for safety records.
-



1. Freezer contents Yes No  
Risk of infection Yes No  
Risk of toxicity Yes No  
Risk from radioactive sources Yes No

(List all potentially hazardous materials that have been stored in this unit.)  
Notes:

2. Contamination of the unit:  
Unit interior Yes No  
No contamination Yes No  
Decontaminated Yes No  
Contaminated Yes No  
Others

3. Instructions for safe repair/maintenance of the unit:  
a) The unit is safe to work on Yes No  
b) There is some danger (see below) Yes No  
Procedure to be adhered to in order to reduce safety risk indicated in b) below.

Date :  
Signature :  
Address, Division :  
Telephone :

Product name :  
Model :  
Serial number :  
Date of installation :

*Please decontaminate the unit yourself before calling the service engineer.*

**Maintenance**

New Brunswick™ HEF® and G Freezers  
English (EN)

## 8 Troubleshooting

### 8.1 General errors

If you are experiencing a problem with your freezer, check the following troubleshooting guides before contacting your Eppendorf authorized service technician.

Symptom/message	Cause	Remedy
Door will not open	1. The door handle is locked. The heated vent port is blocked.	1. Unlock the door handle. 2. Break up the ice in the vent port using the plunger, (see <i>Heated vent port on p. 43</i> ). If the door will not open: ▶ Call Eppendorf service.
<b>FILTER-CLEAN</b> LED lights up	• Filter is contaminated.	▶ Clean the filter, (see <i>Air intake grill and filter on p. 43</i> ). If the LED remains lit: ▶ Call Eppendorf service.

### 8.2 Error messages

Your electronically-controlled freezer incorporates the unique Systems Monitoring And Reporting Technology (S.M.A.R.T. Plus™) self-diagnostic software to diagnose faults in its electronic systems, its probes and/or its refrigeration system.

This table interprets error codes that may appear in the control panel display:

Symptom/ message	Cause	Remedy
E-01	• PT100 Probe 1 failure. This probe, located inside the freezer cabinet, indicates cabinet temperature.	▶ Call Eppendorf service department.
E-02	• Probe 2 failure. This probe monitors the cascade condenser.	▶ Call Eppendorf service department.
E-03	• This probe monitors the air-cooled condenser.	▶ Call Eppendorf service department.

## Troubleshooting

New Brunswick™ HEF® and G Freezers  
English (EN)

Symptom/ message	Cause	Remedy
E-04	<p>Air-cooled condenser temperature too high:</p> <ol style="list-style-type: none"> <li>Filter may be blocked.</li> </ol> <p>Ambient temperature may be too high.</p> <p>If alarm continues to sound:</p> <ul style="list-style-type: none"> <li>Fan may have failed.</li> <li>Water supply not turned on, insufficient flow, regulating valve not opening or defective (water-cooled version only).</li> </ul>	<ol style="list-style-type: none"> <li>Clean filter according to the instructions (see <i>Air intake grill and filter on p. 43</i>).</li> <li>Cool the room.</li> </ol> <p>► Call Eppendorf service department.</p>



A fan is required to cool the compressors on the water-cooled models.

### 8.3 After a mains/power failure

If mains/power is interrupted, the **POWER-FAIL** indicator lamp (see Fig. 5-1 on p. 27), Item 3, will illuminate. In addition, the audible alarm will sound and the display will flash at approximately 10-second intervals.

When mains/power is restored, both alarm and light will automatically be cancelled.

If mains/power has been interrupted for only a short time, the internal temperature of the freezer will not have risen above the temperature setpoint (the user-set alarm threshold), so normal operation will be resumed immediately.

If the interruption was long enough for the internal temperature to rise above the temperature setpoint, the **TEMP-ALARM** indicator will illuminate. If the internal temperature does not fall below the temperature setpoint within the programmed time after mains/power was restored, the audible alarm will sound again. The TEMP-ALARM indicator will extinguish when the internal temperature reaches the High Alarm temperature set point.

### 8.4 Interior warming

If the lid or door is left open long enough for the internal temperature to rise above the temperature setpoint, the same effects will be observed as described above regarding power failure.

To minimize the risk of this happening, the lid or door should only be opened when necessary, for a short period of time.

The upright freezers are fitted with internal doors which latch shut, minimizing temperature rise when the outer door is opened. Chest freezers are fitted with inner insulating lids to ensure efficient running of the freezer. The lids should remain fitted at all times when the freezer is running.

**Troubleshooting**

New Brunswick™ HEF® and G Freezers  
English (EN)

## 9 Technical data

### 9.0.1 Specifications

### 9.0.2 Specifications for U725-G Air-cooled and U725-G Water-cooled freezers

Model No.	U725-G Air-cooled	U725-G Water-cooled
Part No.	U9440-0005 (230 V, 50 Hz)	U9440-0004 (230 V, 50 Hz)
Internal Dimensions: Height x Width x Depth	1365 x 865 x 615 mm 53.7 x 34.1 x 24.2 in	1365 x 865 x 615 mm 53.7 x 34.1 x 24.2 in
External Dimensions: Height x Width x Depth	1950 x 1025 x 867 mm 76.8 x 40.4 x 34.1 in	1950 x 1025 x 867 mm 76.8 x 40.4 x 34.1 in
Capacity	725 L 25.6 cu ft	725 L 25.6 cu ft
Net Weight	315 kg 694 lb	317 kg 699 lb
Lock	Standard	Standard
No. Compartments	3	3
Interior	Stainless steel grade 304 L	
Alarms	High/Low temperature, power fail, battery low, filter clean, fault	
Insulation Material	Vacuum insulation panels and polyurethane foam	
*Noise level	57.6 dB	57.3 dB
Remote alarm port	Standard	Standard
RS-485 interface	Optional	Optional
Refrigerants:	High Stage Refrigerant: R290 Low Stage Refrigerant: R170	
‡Power Consumption:	508 W	471 W
Heat output:	502 W, 1713 BTU/h	213 W, 727 BTU/h (air) 256 W, 874 BTU/h (water)
Mains/Power Source and Current Rating:	8.5 A	8.5 A
<b>Pull down time: From ambient to -85 °C (freezer empty)</b>		
	4.7 h	4.7 h
Performance	-50 °C to -86 °C at 32 °C maximum ambient operating temperature	

**Technical data**

New Brunswick™ HEF® and G Freezers  
English (EN)

Model No.	U725-G Air-cooled	U725-G Water-cooled
<b>Environmental Conditions</b>	All freezers use components tested to CE specifications listed below: <ul style="list-style-type: none"> <li>• Indoor use</li> <li>• Altitude limit up to 2000 m (2187.23 yd)</li> <li>• Ambient temperature range 10 °C – 32 °C</li> <li>• Maximum relative humidity 80 % for temperatures up to 31 °C, decreasing linearly to 50 % relative humidity at 40 °C</li> <li>• Mains/power supply voltage fluctuations not to exceed ± 10 % of the nominal voltage</li> <li>• Installation category II</li> <li>• Pollution degree 2</li> </ul>	

\* Noise test conditions - Measurements taken from a distance of 2 m and 1 m from the floor. Background noise level = 30 dB

‡ Power consumption values are average readings conducted under controlled conditions - Freezer set to -80 °C, ambient 21 °C – 23 °C at rated mains/electrical supply. No load.

9.0.3 Specifications for U410 HEF and U570 HEF freezers

Model No.	U410 HEF	U570 HEF
<b>Part No.</b>	U9260-0008 (230 V, 50 Hz) U9260-0007 (115 V, 60 Hz)	U9270-0008 (230 V, 50 Hz) U9270-0007 (115 V, 60 Hz)
<b>Internal Dimensions: Height x Width x Depth</b>	1265 x 550 x 575 mm 49.8 x 21.6 x 22.6 in	1265 x 765 x 575 mm 49.8 x 30.1 x 22.6 in
<b>External Dimensions: Height x Width x Depth</b>	1930 x 800 x 852 mm 76.0 x 31.5 x 33.5 in	1940 x 1025 x 852 mm 76.4 x 40.3 x 33.5 in
<b>Capacity</b>	410 L 14.5 cu ft	570 L 20.0 cu ft
<b>Net Weight</b>	262 kg 576 lb	296 kg 651 lb
<b>Lock</b>	Standard	Standard
<b>No. Compartments</b>	5	5
<b>Interior</b>	Stainless steel grade 304 L	
<b>Alarms</b>	High/Low temperature, power fail, battery low, filter clean, fault	
<b>Insulation Material</b>	Vacuum Insulation Panels and urethane foam	
<b>*Noise level</b>	53.0 dB for 230 V 57.0 dB for 115 V	58.0 dB for 230 V 58.5 dB for 115 V
<b>Remote alarm port</b>	Standard	Standard
<b>RS-485 interface</b>	Optional	Optional
<b>Refrigerants:</b>		
<b>230 V, 50 Hz</b>	High Stage Refrigerant: R290 Low Stage Refrigerant: R170	
<b>115 V, 60 Hz</b>	High Stage Refrigerant: R404A Low Stage Refrigerant: R508B	
<b>‡Power Consumption:</b>		
<b>230 V, 50 Hz</b>	350 W	371 W
<b>115 V, 60 Hz</b>	358 W	508 W
<b>Mains/Power Source and Current Rating:</b>		
<b>230 V, 50 Hz</b>	5.0 A	6.0 A
<b>115 V, 60 Hz</b>	16.5 A	16.5 A
<b>Heat Output:</b>		
<b>115 V, 60 Hz</b>	505 W, 1723 BTU/h	630 W, 2150 BTU/h
<b>230 V, 50 Hz</b>	525 W, 1791 BTU/h	520 W, 1774 BTU/h
<b>Pull down time: from ambient to -85 °C (freezer empty)</b>		
<b>230 V, 50 Hz</b>	4.7 h	4.7 h
<b>115 V, 60 Hz</b>	5.8 h	6.0
<b>Performance</b>	-50 °C to -86 °C at 32 °C maximum ambient operating temperature	

**Technical data**

New Brunswick™ HEF® and G Freezers  
English (EN)

Model No.	U410 HEF	U570 HEF
<b>Environmental Conditions</b>	All freezers use components tested to CE specifications listed below: <ul style="list-style-type: none"> <li>• Indoor use</li> <li>• Altitude limit up to 2000 m (2187.23 yd)</li> <li>• Ambient temperature range 10 °C to 32 °C</li> <li>• Maximum relative humidity 80 % for temperatures up to 31 °C, decreasing linearly to 50 % relative humidity at 40 °C</li> <li>• Mains/power supply voltage fluctuations not to exceed <math>\pm 10</math> % of the nominal voltage</li> <li>• Installation category II</li> <li>• Pollution degree 2</li> </ul>	

\* Noise test conditions - Measurements taken from a distance of 2.0 m and 1 m from the floor. Background noise level = 30 dB

‡ Power consumption values are average readings conducted under controlled conditions - Freezer set to -80 °C, ambient 21 °C – 23 °C at rated mains/electrical supply. No load.

9.0.4 Specifications for C660 HEF freezers

Model No.	C660 HEF
Part No.	U9250-0008 (230 V, 50 Hz) U9250-0009 (208 V – 230 V, 60 Hz)
Internal Dimensions: Height x Width x Depth	760 x 1470 x 590 mm 30.0 x 57.9 x 23.2 in
External Dimensions: Height x Width x Depth	1090 x 2050 x 845 mm 42.3 x 80.7 x 33.3 in
Capacity	660 L 23.3 cu ft
Net Weight	304 kg 670 lb
Lock	Standard
No. Compartments	N/A
Interior	Stainless steel grade 304 L
Alarms	High/Low temperature, power fail, battery low, filter clean, fault
Insulation Material	Vacuum Insulation Panels and polyurethane foam
*Noise level	58.5 dB (230 V) 61.0 dB (208 V – 230 V)
Remote alarm port	Standard
RS-485 interface	Optional
Refrigerants:	
230 V, 50 Hz	High Stage Refrigerant: R290 Low Stage Refrigerant: R170
208 V – 230 V, 60 Hz	High Stage Refrigerant: R404A Low Stage Refrigerant: R508B
‡Power Consumption:	
230 V, 50 Hz	475 W
208 - 230 V, 60 Hz	480 W
Mains/Power Source and Current Rating:	
230 V, 50 Hz	6.0 A
208 V – 230 V, 60 Hz	8.0 A
Heat output:	
230 V , 50 Hz	580 W, 1979 BTU/h
208-230V, 60 Hz	580 W, 1979 BTU/h
Pull down time: From ambient to -85 °C (freezer empty)	
230 V , 50 Hz	5.0 h
208-230V, 60 Hz	6.0 h

**Technical data**

New Brunswick™ HEF® and G Freezers  
English (EN)

Model No.	C660 HEF
<b>Performance</b>	-50 °C to -86 °C at 32 °C maximum ambient operating temperature
<b>Environmental Conditions</b>	All freezers are designed for: <ul style="list-style-type: none"> <li>• Indoor use</li> <li>• Altitude limit up to 2000 m (2187.23 yd)</li> <li>• Ambient temperature range 10 °C – 32 °C</li> <li>• Maximum relative humidity 80 % for temperatures up to 31 °C, decreasing linearly to 50 % relative humidity at 40 °C</li> <li>• Mains/power supply voltage fluctuations not to exceed <math>\pm 10</math> % of the nominal voltage</li> <li>• Installation category II</li> <li>• Pollution degree 2</li> </ul>

\* Noise test conditions - Measurements taken from a distance of 2 m and 1 m from the floor. Background noise level = 30 dB

‡ Power consumption values are average readings conducted under controlled conditions - Freezer set to -80 °C, ambient 21 °C – 23 °C at rated mains/electrical supply. No load.

### 9.0.5 Compliances



#### **WARNING!**

- ▶ Any modification or changes made to this device, unless explicitly approved by Eppendorf, will invalidate the authorization of this device. Operation of an unauthorized device is prohibited under Section 302 of the Communications Act of 1934, as amended, and Subpart 1 of Part 2 of Chapter 47 of the Code of Federal Regulations.



This equipment has been tested and found to comply with the limits for a Class B digital device, pursuant to Part 15 of the FCC Rules. These limits are designed to provide reasonable protection against harmful interference in a residential installation. This equipment generates, uses and can radiate radio frequency energy and, if not installed and used in accordance with the instructions, may cause harmful interference to radio communications. However, there is no guarantee that interference will not occur in a particular installation. If this equipment does cause harmful interference to radio or television reception, which can be determined by turning the equipment off and on, the user is encouraged to try to correct the interference by one or more of the following measures:

- Reorient or relocate the receiving antenna.
- Increase the separation between the equipment and receiver
- Connect the equipment into an outlet on a circuit different from that to which the receiver is connected.
- Consult the dealer or an experienced radio/TV technician for help.

## 10 Ordering information

### 10.1 Accessories

A number of accessories are available for Eppendorf line of ultra-low temperature freezers. Contact your local Eppendorf representative or distributor for details.

#### 10.1.1 TCA-3 temperature monitoring system

The TCA-3 monitoring system is a temperature monitor with alarm, electronic chart recorder, and auto-dialer that communicates via the internet for remote monitoring from anywhere in the world. Ask your Eppendorf sales representative for availability.

#### 10.1.2 Auto-dialers

Auto-dialers can call a set of preprogrammed telephone numbers in the event of an alarm condition and connect right into the freezer's remote alarm port.

#### 10.1.3 Temperature probes

Additional Temperature Probes (such as the TCA-3 monitoring system) can be installed upon request for an external alarm system or for validation.

#### 10.1.4 Validation packages

Installation and operational qualifications are available.

#### 10.1.5 Padlock adapter kits

Padlock adapter kits allow up to two user-supplied padlocks to be secured to outer door handle for extra security.

#### 10.1.6 CO<sub>2</sub> and LN<sub>2</sub> back-up systems

These systems are available to temporarily protect the contents of the freezer against the consequences of freezer failure or power failure. In an emergency, the system can inject either liquid carbon dioxide or liquid nitrogen from a storage bottle. Carbon dioxide back-up systems will maintain temperatures between -40 °C and -70 °C (subject to environmental conditions) for a period of up to 48 h, during which time the freezer can be repaired. Liquid nitrogen back-up systems will maintain the freezer temperature at -86 °C.

CO<sub>2</sub> and LN<sub>2</sub> back up systems can be retrofitted by the user. Contact your local Eppendorf distributor for options available. Instructions are included in the kit.

**Ordering information**

New Brunswick™ HEF® and G Freezers  
English (EN)

<b>Order No. (International)</b>	<b>Description</b>
U9043-0002	Innova®/G CO <sub>2</sub> backup, 115 V – 230 V, 60 Hz
U9043-0004	Innova®/G CO <sub>2</sub> backup, 230 V, 50 Hz
U9043-0006	Premium/HEF® CO <sub>2</sub> backup, 115 V – 230 V, 60 Hz
U9043-0008	Premium/HEF® CO <sub>2</sub> backup, 230 V, 50 Hz
U9044-0002	Innova®/G LN <sub>2</sub> backup, 115 V – 230 V, 60 Hz
U9044-0004	Innova®/G LN <sub>2</sub> backup, 230 V, 50 Hz
U9044-0006	Premium/HEF® LN <sub>2</sub> backup, 115 V – 230 V, 60 Hz
U9044-0008	Premium/HEF® LN <sub>2</sub> backup, 230 V, 50 Hz

### 10.1.7 Inventory racking systems

A very comprehensive set of anodized aluminium racks is available. These are designed to accommodate various sizes of boxes neatly, while giving maximum packing density in the freezer. Stainless-steel shelves and water proof boxes as well as custom racking are also available.

### 10.1.8 Chart recorder

A chart recorder is available to provide a continuous record of the temperature inside the freezer over a period of seven days. The record is presented on a circular chart.

The following items are available for all freezer models:

<b>Order No. (International)</b>	<b>Description</b>	<b>Quantity</b>
P0625-2100	Chart Recorder Kit	1
P0625-2110	Chart Recorder Paper, Range -50 °C to -100 °C	
K0660-0051	Chart Recorder Pens	3

### 10.1.9 BioCommand SFI datalogging software (RS-485 interface)

BioCommand® SFI Track and Trend software is available to trend and archive data from as many as 32 shakers, CO<sub>2</sub> incubators, and/or freezers, simultaneously. This PC-based software works with any OPC-compliant equipment with an RS-232 or RS-485 port.

## 11 Transport, storage and disposal

### 11.1 Shut down

1. Switch the battery switch off before transporting or storing the equipment, (see *Battery backup switch on p. 38*).

### 11.2 Transport



**WARNING! Risk of personal injury**

Lifting and transporting the freezer without suitable equipments can result in crushing and other injuries.

- ▶ Use a mechanical lifting equipment to load and unload the freezer.



**CAUTION! Risk of material damage**

Vibrations and impacts can cause the hermetically sealed compressors to slip out of their suspension system.

- ▶ Do not tilt the equipment.
  - ▶ Avoid vibrations and impacts.
- 

Perform the following steps if relocation is necessary:

1. Remove all shelves, racks, and boxes.
2. Carefully move the freezer.

### 11.3 Disposal

In case the product is to be disposed of, the relevant legal regulations are to be observed.

**Information on the disposal of electrical and electronic devices in the European Community:**

Within the European Community, the disposal of electrical devices is regulated by national regulations based on EU Directive 2012/19/EU pertaining to waste electrical and electronic equipment (WEEE).

According to these regulations, any devices supplied after August 13, 2005, in the business-to-business sphere, to which this product is assigned, may no longer be disposed of in municipal or domestic waste. To document this, they have been marked with the following identification:



Because disposal regulations may differ from one country to another within the EU, please contact your supplier if necessary.

In Germany, this is mandatory from March 23, 2006. From this date, the manufacturer has to offer a suitable method of return for all devices supplied after August 13, 2005. For all devices supplied before August 13, 2005, the last user is responsible for the correct disposal.

**Index**

**A**

Accessories.....61  
 Adjusting the shelf .....24  
 Air intake .....43  
 Alarm .....38  
 Alarm activation .....33  
 Alarm test/mute key .....38  
 Audible alarm .....38  
 Auto-dialers .....61  
 Auto-reset.....17  
 Automatic reset .....17

**B**

Battery activation .....33  
 Battery backup switch .....38  
 Battery replacement .....48

**C**

C660 HEF Specifications.....59  
 Caution, explanation of .....7  
 CFC.....8  
 Chart recorder .....62  
 Chest freezer, front view.....14  
 Cleaning .....43, 44  
 Clearance.....19  
 CO2 back-up system.....61  
 Control panel.....27  
 Copyright.....2  
 Custom-made racks.....62

**D**

Danger, explanation of .....7  
 Defrosting.....45

Disposal ..... 64  
 Door seal..... 44  
 Door/lid stuck ..... 34

**E**

Electrical connection ..... 31  
 Electrical requirements..... 31  
 Error codes ..... 51  
 External monitoring..... 39

**F**

Factory-set temperature ..... 34  
 Fail, mains/power ..... 52

**H**

Hazard symbols ..... 7  
 HCFC..... 8

**I**

Ice in vent ..... 34, 43  
 Indicator lights..... 17  
 Inspection of boxes..... 15  
 Intended use ..... 12  
 Interior and shelves ..... 43

**L**

Lid/door stuck ..... 34  
 LN2 back-up system ..... 61  
 Lock key..... 34  
 Lockable panel..... 33

**M**

Mains/power failure..... 52  
 Mains/power supply ..... 31  
 Manual conventions..... 8

**Index**

New Brunswick™ HEF® and G Freezers  
English (EN)

min .....	8	Setpoint, temperature .....	52
Monitoring.....	39, 62	Setting the operating temperature .....	34
Moving freezer .....	63	Shelf, adjusting .....	24
<b>N</b>			
Notice, explanation of .....	7	Shelves.....	43
<b>P</b>			
Packing list verification .....	15	Specifications, C660 HEF .....	59
Panel, removing.....	32	Specifications, U410 HEF .....	57
Part numbers.....	62	Specifications, U570 HEF .....	57
Plunger .....	34, 43	Specifications,U725-G .....	55
Power cord .....	31	Symbols used.....	8
Power fail.....	34	<b>T</b>	
Power failure .....	38	Temp alarm.....	52
Power supply/mains .....	31	Temperature alarms.....	27
Programming.....	34	Temperature probes.....	61
<b>R</b>			
Racks .....	62	Temperature setpoint.....	34, 52
Recorder pens .....	62	Testing alarm .....	47
Recorder, chart.....	62	Testing alarm monitoring socket.....	34
Remote control .....	13	Testing indicator lamps .....	47
Remote monitoring .....	39, 62	Trademarks .....	2
Removing lockable panel .....	32	Troubleshooting.....	51
Removing upright freezer lock barrel .....	25	Turning on the equipment.....	31
Requirements, water supply.....	21	<b>U</b>	
Rise in temperature .....	52	U410 HEF Specifications.....	57
rpm .....	9	U570 HEF Specifications.....	57
RS-485 computer interface .....	62	U725-G Specifications .....	55
<b>S</b>			
S.M.A.R.T. Plus.....	27, 51	Unpacking boxes .....	15
Safety.....	12	Upright freezer, front view .....	13
Set temp key.....	34	Upright freezer, side view .....	13
		Using this manual.....	7
		<b>V</b>	
		Vacuum effect.....	34
		Validation packages.....	61

Vent ..... 34, 43

**W**

Warming.....52

Warning, explanation of.....7

Water cooled models.....21

Water-cooled freezer, rear view ..... 13

Water-cooled freezer, side view ..... 13

**Index**

New Brunswick™ HEF® and G Freezers  
English (EN)

# Declaration of Conformity

The products named below fulfill the requirements of directives and standards listed. In the case of unauthorized modifications to the product or an unintended use this declaration becomes invalid.

**Product name:**

Innova®: Model No. U725-G Air Cooled, U725-G Water Cooled and

Premium: U410 HEF, U570 HEF & C660 HEF

including accessories

**Product type:**

U Prefix designates Upright Freezer

C Prefix designates Chest Freezer

**Relevant directives / standards:**

2006/95/EC: EN 61010-1,

UL 61010-1, CSA C22.2 No. 61010-1 (US Voltage 60 Hz Models)

2004/108/EC: EN 61326-1

FCC Part 15 Class B (US Voltage 60Hz Models)

2011/65/EU

2012/19/EU



Management Board



Portfolio Management

Date: November 25, 2013

Your local distributor: [www.eppendorf.com/contact](http://www.eppendorf.com/contact)  
Eppendorf AG · 22331 Hamburg · Germany  
[eppendorf@eppendorf.com](mailto:eppendorf@eppendorf.com)

ISO 9001  
Certified

ISO 13485  
Certified

ISO 14001  
Certified

Eppendorf® and the Eppendorf Logo are registered trademarks of Eppendorf AG Hamburg/Germany.  
All rights reserved incl. graphics and pictures. Copyright 2013 © by Eppendorf AG.

U9440-9999-00





# Evaluate Your Manual

Give us your feedback.  
[www.eppendorf.com/manualfeedback](http://www.eppendorf.com/manualfeedback)