

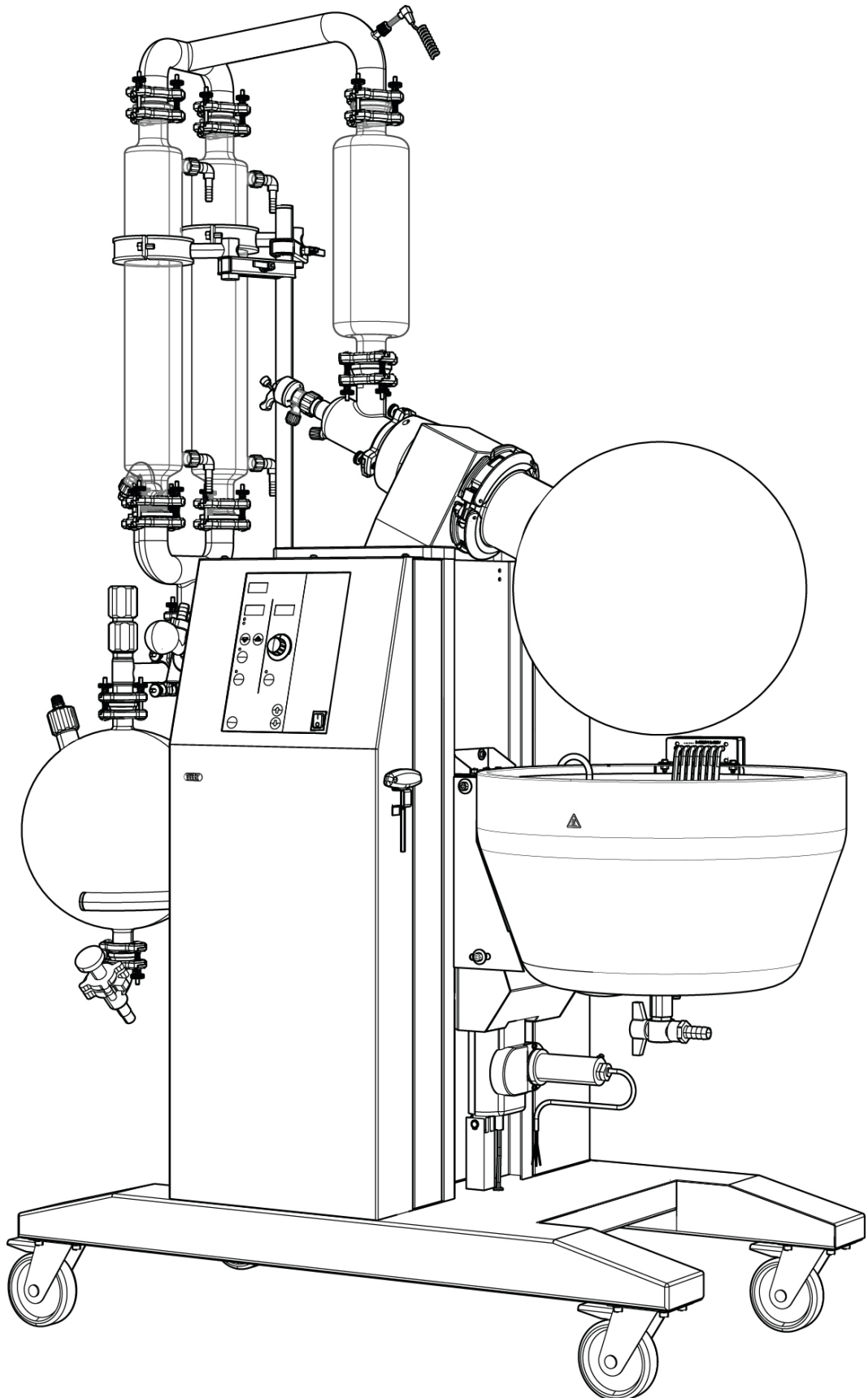

Operation Manual

Rotavapor® R-250





LAB Online Exhibition



Imprint

Product Identification:
Operation Manual (Original), Rotavapor® R-250

096796H en

Publication date: 02.2018

BÜCHI Labortechnik AG
Meierseggestrasse 40
Postfach
CH-9230 Flawil 1

E-Mail: quality@buchi.com

BUCHI reserves the right to make changes to the manual as deemed necessary in the light of experience; especially in respect to structure, illustrations and technical detail.

This manual is copyright. Information from it may not be reproduced, distributed, or used for competitive purposes, nor made available to third parties. The manufacture of any component with the aid of this manual without prior written agreement is also prohibited.

Table of Contents

1	Scope of Delivery			
2	Safety			
3	Function			
4	Putting into Operation			
4.1	Installation Location			
4.2	Unpacking			
4.3	Connecting to the Source of Energy			
4.4	Setting Up the Support Rod			
4.5	Fitting and Removing the EasyClamp Connection			
4.6	Installation of the Receiving Fixture			
4.7	Installation of the Reflux Glass Assembly			
4.8	Installation of the Descending Glass Assembly			
4.9	Attaching and Removing Flasks			
4.10	Operating the Shut-off tap			
4.11	Operating the Inlet Valve			
4.12	Flask Suction (Optional)			
4.13	Vacuum Controller (Accessories)			
4.14	Connections to the Vacuum and Cooling Medium			
4.15	Heating Medium			
4.16	Checking the Installation			
5	Operation	22		
5.1	Layout of Operating and Display Elements	22		
5.2	Setting the Maximum Setpoint Temperature and Lowering the Bath Automatically	22		
5.3	Selection of Distillation Temperature	23		
5.4	List of Solvents	24		
5.5	Troubleshooting	25		
5.6	Reset of the over-temperature protection	25		
5.7	Error Messages	26		
4	Maintenance			27
6.1	Cleaning			27
5	6.2 Dismantling/Assembling the Snap Flange Coupling			28
6.3	Removing/Inserting the Evaporating Flask Seal			29
8	6.4 Changing the Seals to the Distribution Head			30
6.5	Installing and Removing the Vacuum Seal			30
9	6.6 Testing for Leaks			31
9	6.7 Customer Service			31
7	Taking out of Operation			32
7.1	Storage			32
7.2	Packing/Transport			32
7.3	Waste Disposal			32
8	Spare Parts and Accessories			33
8.1	Spare Parts, Glass Assemblies R, RB			34
8.2	Spare Parts, Glass Assemblies D, D3			35
8.3	Spare Parts, Drip Tray			36
8.4	Seals, Tools			37
8.5	Accessories			39
8.6	Hose Connections			41
8.7	Connections to Rear Panel			42
9	Appendix			43
9.1	Technical Data			43
9.2	Materials Used			43



Read this Operating Manual through carefully before using the Rotavapor **R-250**. Always keep these Instructions readily available in the immediate vicinity of the unit so that they make be consulted at any time.

Chapter 2 contains important safety rules which must be observed to ensure the safe operation of the rotary evaporator.

We reserve the right to make technical changes without prior notification. No portion of this Operating Manual may be reproduced, processed using electronic or optical systems, duplicated, or distributed in any form without the prior written approval of BÜCHI Labortechnik AG.

All rights reserved. © BÜCHI Labortechnik AG, 2013

en,
R-250 Operation Manual

Ordering No.
96796

1 Scope of Delivery

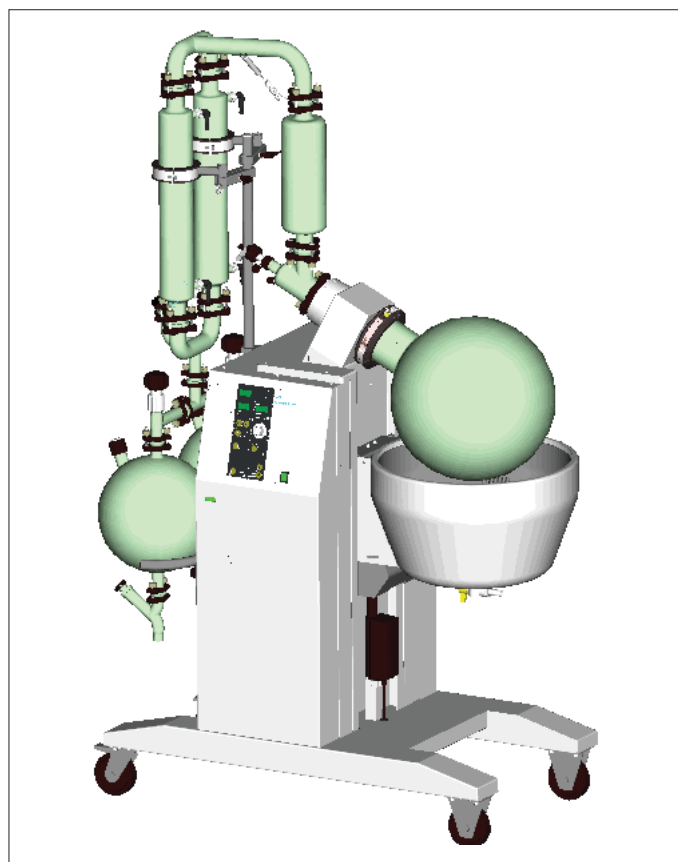

Fig. 1.1: R-250, Overall view

Component

1	Chassis, complete, with
	Control
	Rotation drive
	Heating bath, complete
1	Glass assembly, comprising
	20 or 50 ltr. evaporating flask
	Condensation assembly
	Receiving assembly

Table 1: Scope of delivery

Standard accessories, comprising Ordering No.

1	Wrench	
1	Hoses, complete	
1	Installation tool	
1	Instruction Manual	
	German	96795
	English	96796
	French	96797
	Italian	96798
	Spanish	96799
1	Documentation CD	97XXX

Table 2: Standard accessories

2 Safety

This unit has been built in accordance with the latest state of the art and with recognized rules of safety. Nevertheless there are certain risks and dangers entailed with this unit:

- whenever the unit is operated by individuals who lack sufficient training;
- whenever the unit is used for some purpose other than its authorized use.

2.1 Symbols



Stop

Information on dangers that can cause serious material damage and severe personal injuries or death.



Warning

Information on dangers that can be injurious to one's health or cause material damage.



Note

Information pointing out technical requirements. A failure to observe such information can lead to malfunctions, uneconomical operation, and losses in production.

2.2 Responsibilities of the Operator

This unit may only be used by technical staff and by individuals who, based on their training or their professional experience, have a good understanding of the dangers that can arise from the its operation.

Staff who do not have this training and individuals who are currently in training must be given careful instructions. This Operating Manual should be used as the basis for such training.

2.3 Authorized Use

The rotary evaporator has been designed for use in technical laboratories and in production. It is authorized for use in applications that work with the evaporation and condensation of solvents.

It is used for:

- Evaporation of solvents and suspensions
- Drying of powders and granulates
- Re-crystallization
- Reactions under reflux
- Synthesis and Cleaning of refined chemicals
- Recycling and concentration of solvents

The authorized use of the Rotavapor also includes its care, upkeep, and careful handling in accordance with the provisions in this Operating Manual.

2.4 Unauthorized Use

Any use other than those indicated above, and any use that is not in conformity with the Technical Data is considered to be misuse. The operator himself bears sole responsibility for all damage or injuries arising from any such use.



The following applications in particular are strictly forbidden:

- The production and processing of materials that can cause spontaneous reactions, e.g., explosives;
- Working without the evaporation flask being immersed in the water bath (risk of breakage);
- The drying of hard, brittle materials (e.g., stones, soil samples) that might cause damage to the receiving flask;
- Sudden shock-cooling of the evaporating flask.



The Rotavapor R-250 is not intended for work done under overpressures.

2.5 Basic Dangers

Basic dangers arise when working with the following:

- The hot water or oil bath (risk of being scalded);
- Contaminated solvents that produce residues from distillation which could cause spontaneous reactions (e.g., metal hydrides);
- Solvents that can produce peroxides (risk of explosions);
- Mixtures with unknown compositions or contamination;
- Damaged glassware;
- Electrostatic charges while working, e.g., during the transfer of combustible solutions and while drying powders;
- Temperatures of coolants that lie below the freezing point of the distillate (A clogging of the distillate cooler due to freezing out can result in too great an overpressure).

2.6 Safety Precautions

All regional and local laws and regulations must be observed.

The Rotavapor has been grounded internally to dissipate any electrostatic charges on it.

It is always mandatory to wear personal protective gear such as **protective eyewear** and **protective clothing**.



The machine must never be rotated without the snap flange coupling being closed.

No distillation may be started unless the evaporating flask is immersed in the bath. There is always the risk that the neck of the flask might break off due to the great weight involved. There is a risk of becoming scalded while changing evaporating flasks. Wearing gloves prevents this.

Check the glass components regularly for possible damage, spreading impact marks, or cracks.



Never interrupt the grounding conductor (protective conductor). Otherwise there will be the risk of an electrical shock!

The operator bears responsibility for providing proper instruction of his operating staff. To aid him in doing this, translations of this Instruction Manual are also available in several other languages. As an integral component of the rotary evaporator, this Instruction Manual must be readily available at all times to the operating staff at the location where they are using the unit.

The operator must inform the manufacturer immediately of any and all events relevant to safety that occur in his use of this equipment.

2.7 Modifications

No modifications are permissible without consulting with and obtaining the written approval of the manufacturer.

No glass assemblies other than those recommended by the manufacturer may be used, nor may any glass components be put together arbitrarily.



Only those components of the rotary evaporator intended for fulfillment of its function may be installed in or removed from the unit. This may be done either by hand, or with the use of the tool supplied along with the unit. The removal of safety devices or covers using some commercially available tool is — other than for authorized commissioning personnel — strictly forbidden. Contact with parts that are electrically live may result in fatal injury!

3 Function

A vacuum rotary evaporator is used for quick single-stage distillations that treat the product gently. The process is based on the evaporation and condensation of solvents in a rotating evaporating flask.

It is possible to work under a vacuum to ensure gentler treatment of the product and increase productive output.

Distillation may be done either under a vacuum or at atmospheric pressure.

A secure tightness is only guaranteed in the low pressure range.

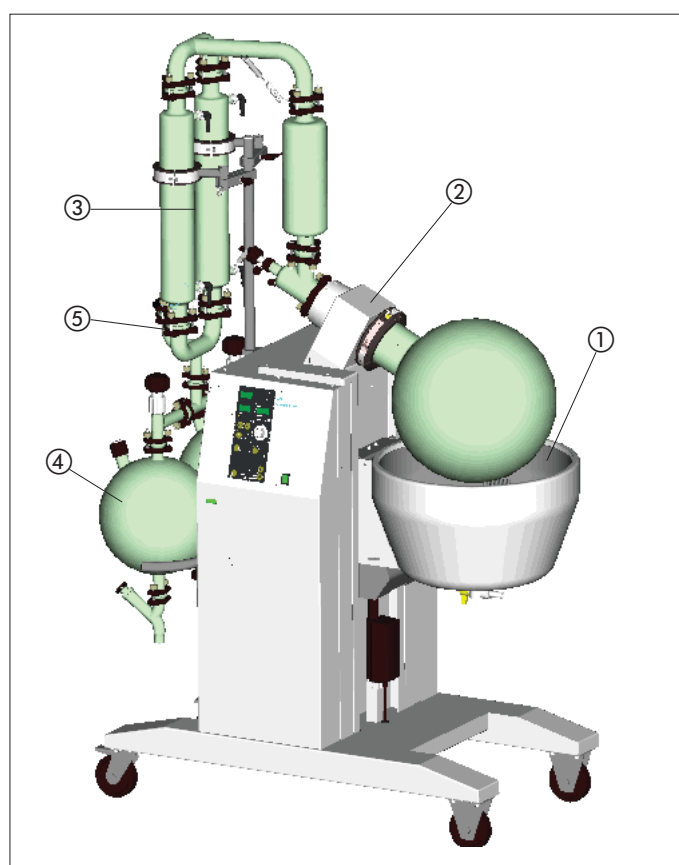

Fig. 3.1: Functional elements of the R-250

① **Evaporation Zone**

The solvent in the evaporating flask is heated by the heating bath. The rotation of the evaporating flask ensures an intensive heat and mass transfer within the contents of the flask, forming a thin film of solvent on the inner surface of the flask. This combination of turbulence and film prevents local overheating and ensures high distillation speed.

② **Rotary Drive**

The drive unit ensures the uniform rotation of the evaporating flask.

③ **Condensing Zone**

The solvent vapor flows into the cooler at a high speed. This is where the energy in the solvent vapor is transferred to the cooling medium (e.g., water). The solvent condenses.

④ **Receiving Flask**

The receiving flask is used to collect the condensate.

⑤ **Vacuum Connection**

The system pressure is reduced so as to lower the boiling point of the solvent. The reduction in thermal loading that results ensures gentle treatment of the product and offers energetic advantages.



The pressure (vacuum) of distillation, the temperature of the heating bath, the rotational speed, and the size of the evaporating flask all affect the evaporation output. Refer to Chapter 5.3 for how to select the optimum conditions of distillation.

4 Putting into Operation



The danger zone around the Rotavapor R-250 can extend outward by up to 10 m. When working inside this danger zone, there is a risk of damaging the glass parts, which could cause them to implode.

4.1 Installation Location

Always set the unit up on a clean, stable, and flat surface. Never at a location where there is a great deal of personal traffic (breaking or broken glass) !

The ambient temperature must be between 5° and 40°C.

The dimensions of the rotary evaporator are:

Height

- | | |
|-------------------|--------|
| - Reflux | 2.45 m |
| - Bullfrog Reflux | 2.10 m |
| - Descending | 2.30 m |

Width

1.40 m

Depth

- | | |
|----------------------------|--------|
| - Single receiver | 0.80 m |
| - Interchangeable receiver | 0.85 m |

4.2 Unpacking



Take care not to break the glass when opening cartons that contain glassware.

Look for any damage after unpacking. It is important that any damage in transit be identified right when unpacking. If necessary, make an immediate assessment of the situation (Notify the post office, the railroad, or the shipping company involved).

Save the original packing for possible transport at a later date.



The transportation security between bath and housing has to be taken away before using the bath lift.

4.3 Connecting to the Source of Energy

The rotary evaporator may only be connected to the electrical supply by the trained person who has been assigned responsibility for this task.

The cooling medium must not exceed the maximum operating pressure of 1.7 bar (shock-free).

4.4 Setting Up the Support Rod

- Place the support rod ① into the holders provided ②, ③ and fix it tight using the locking screw.
- Put on the positioning ring over the rod. (Glass assembly D3 has two positioning rings.)
- Lay the pivoting clamps on the top of the positioning ring. (Glass assembly D3 has two pivoting clamps on the upper ring and one pivoting clamp on the lower ring.)
- Fit the flask supports ④, including the positioning nut, on the lower support rod ⑤. Set the flask support with the positioning nut approx. 2 cm above the upper edge of the retainer.

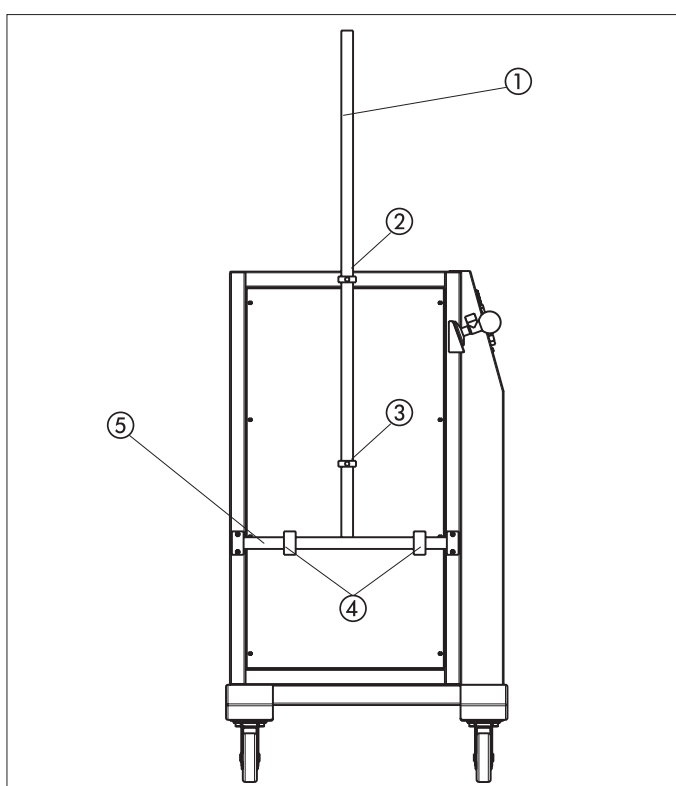

Fig. 4.1: Fitting the support rod

4.5 Attachement and Removal of the EasyClamp Connection

Attachment of the EasyClamp

- Carefully lay the EasyClamp around the glass and fold the top and bottom segments together, closing them at their open connection point.
- Insert the bolt that does not have a spacer spring, and tighten the knurled nuts slightly.
- Tighten all knurled nuts uniformly by hand.

Note:

Always tighten the knurled nuts by hand and not to the block (with the spring pressed together completely). Otherwise the prestressing will be lost.

There must always be a gap of about 2 mm between the knurled nut and the support surface.



Fig. 4.2: Attachment of the EasyClamp

Removal of the EasyClamp

On all EasyClamp connections, **only the bolt without a spacer spring** has to be removed in order to open the connection.

- Release the knurled nuts on all (2 or 3) bolts until the springs have been relieved. Do not, however, screw the nut all the way off.
- On the bolt that does not have a spacer spring, release the knurled nut far enough (without removing it completely) so that the bolt can be tilted out and removed as a unit.
- At the connection point, which is now open, spread the top and bottom segments apart and carefully remove the EasyClamp.



Fig. 4.3: Removal of the EasyClamp



4.6 Installation of the Receiving Glass Assembly

All glassware used must be intact, with no signs of cracks, spreading impact marks, or other damage. Inspect the glassware visually before installing it.

Single receiver

- Insert the supporting ring ① into the connecting fitting ②.
- Secure the outlet valve ③ to the flask ④ using a DN 25 EasyClamp connection.
- Connect the branching piece ⑤ to the flask ④.
- Insert the shut-off tap ⑥ and tighten it firmly.

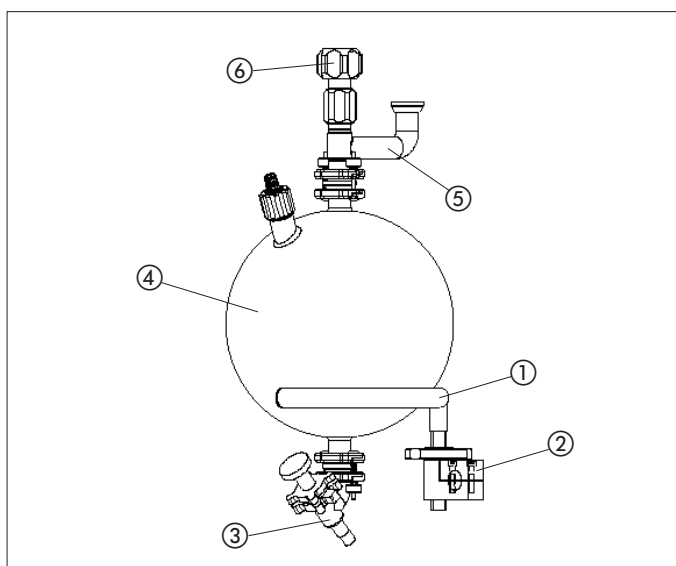

Fig. 4.4: Single receiver

Interchangeable receiver

- Insert the supporting rings ① into the connecting fitting ②.
- Secure the outlet valves ③ to the flask ④ using a DN 25 EasyClamp connection.
- Connect each branching piece ⑤ to the flask ④ and insert the branching piece ⑥. Connect using four EasyClamp connections.
- Insert the shut-off tap ⑦ and tighten it firmly.

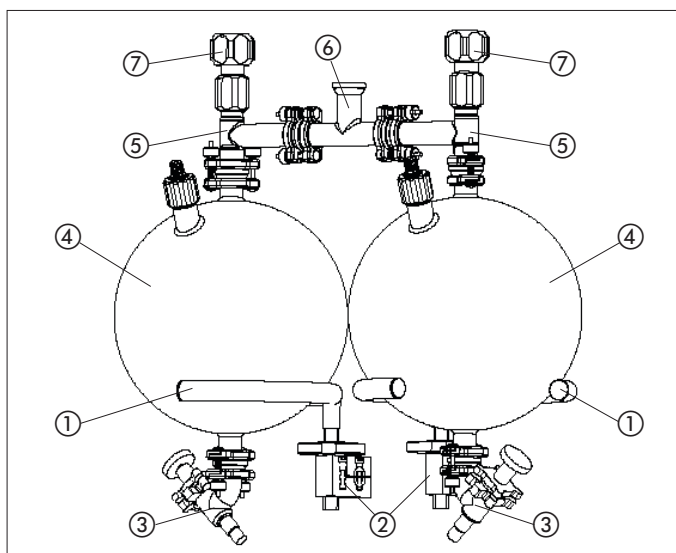

Fig. 4.5: Interchangeable receiver

4.7 Installation of the Reflux Glass Assembly



All glassware used must be intact, with no signs of cracks, spreading impact marks, or other damage. Inspect the glassware visually before installing it.

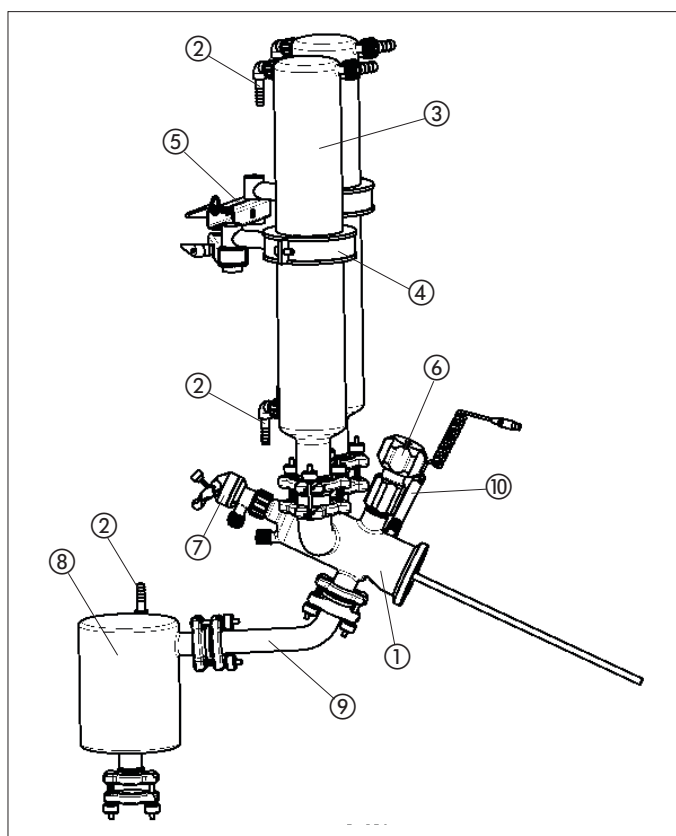

Fig. 4.6: Reflux glass assembly

- Fix the reflux distribution head ① in position on the gear head using a DN 70 EasyClamp connection.
- Fit the cooling water hose nipples ② to both coolers ③.
- Introduce both coolers ③, together with the cooler holders ④, into the pivoting clamps ⑤ and connect them to the distribution head (2 x DN 40 EasyClamp connections).
- Align the coolers ③ in a vertical position and fix in place with the pivoting clamps ⑤.
- Screw the shut-off tap ⑥ into the distribution head ① and tighten it firmly.
- Insert the inlet tap ⑦ into the distribution head and tighten the SVL 30 nut.
- Place the condensate cooler ⑧ on the drip tray and connect it using the EasyClamp connection. Fit the connecting pipe ⑨ between the condensate cooler and the distribution head ① and secure it (2 x DN 25 EasyClamp connections).
- Screw the temperature sensor ⑩ into the distribution head ①.
- Tighten all EasyClamp connections evenly and in parallel.
- Turn the positioning nut to raise the flask support. Connect the receiving flask to the condensation flask.

4.8 Installation of the Descending Glass Assembly



All glassware used must be intact, with no signs of cracks, spreading impact marks, or other damage. Inspect the glassware visually before installing it.

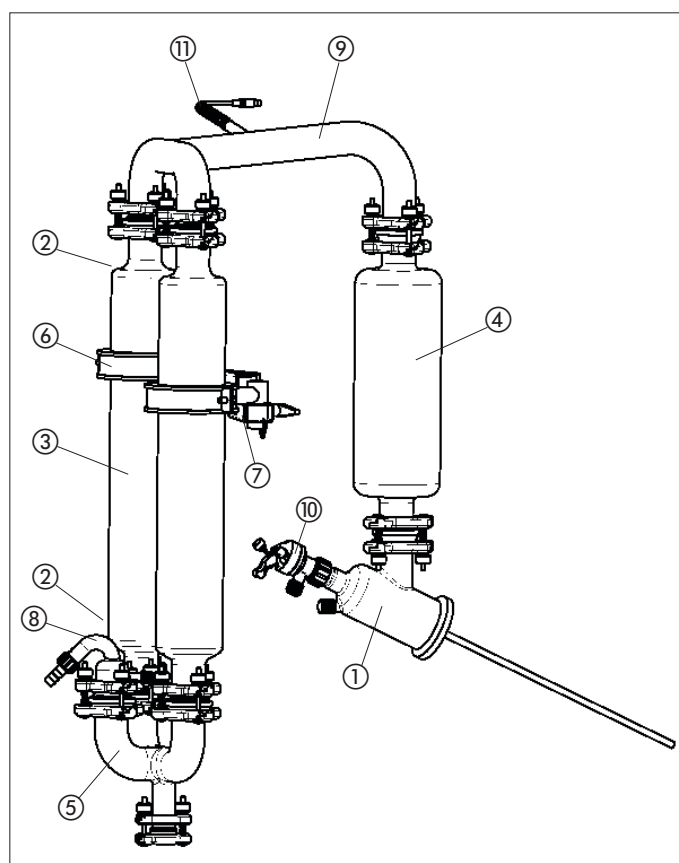

Fig. 4.7: Descending glass assembly

- Fix the descending distributor head ① in position on the gear head using the DN 70 EasyClamp connection.
- Fit the cooling water hose nipples ② to the two or, if appropriate, three coolers ③.
- Put the expansion vessel ④ onto the distribution head ① and secure it with the DN 40 EasyClamp connection.
- Fit the three-way fitting ⑤ onto the receiver using the DN 25 EasyClamp connection.
- Secure the cooler holder ⑥ to the two or three coolers ③, as appropriate, and insert in the pivoting clamps ⑦.
- Fit the vacuum connector ⑧ or the third cooler.
- Fit the branching piece ⑨ on the cooler ③ and the expansion vessel ④ and connect it using the EasyClamp connection. Align the glass components in a vertical position and secure them using the pivoting clamps ⑦.
- Fit the inlet tap ⑩ into the distribution head and tighten the SVL 30 nut.
- Screw the temperature sensor ⑪ into the branching piece ⑨.
- Tighten all EasyClamp connections evenly and in parallel.
- Turn the positioning nut to raise the flask support. Connect the bracket of the receiving flask to the condensation flask.



Fig. 4.8: Fitting the flask

4.9 Attaching and Removing the Evaporating Flasks

Attaching the flask

- With the snap flange coupling open, place the flask in position (by hand, using the manual flask handler or the crane).



Fig. 4.9: Closing the snap flange coupling

- Close the first segment of the snap flange coupling. (The hook must latch in.)
- Close the second segment of the snap flange coupling using the closure screw that can be folded down to connect the two segments.



Fig. 4.10: Tightening the snap flange coupling

- Tighten the closure screw with ca. 4 Nm (to prevent glass breakage) using the hexagon wrench supplied.



Fig. 4.11: Releasing the snap flange coupling

Removing the flask

- Slacken off the closure screw using the hexagon wrench.
- Support the flask by hand or using the manual flask handler and then carefully lift up the closure screw.



Fig. 4.12: Opening the snap flange coupling

- Push in the hook to release the second segment and fold it outwards.



Fig. 4.13: Removing the flask

- Lift the flask out at the top and remove it.

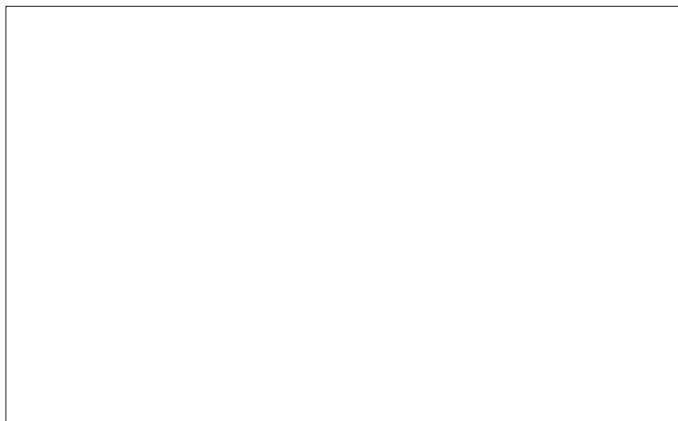

Fig. 4.14: Shut-off tap

4.10 Operating the Shut-off tap

The shut-off tap is of a special design. It does not have a continuous thread on its inside for tightening it, but rather a sliding plane with two fixed latching positions. The closing pressure when it is in a closed position is provided by a prestressed spring.

- Insert the shut-off tap in the distribution head or branching piece and turn the white lower section of the grip ① clockwise until the tap is tightly seated.
- To open:
Turn the black upper section of the grip ② clockwise until the shut-off tap latches into the first position. If the opening is not large enough, continue turning until the tap reaches the second latching position.

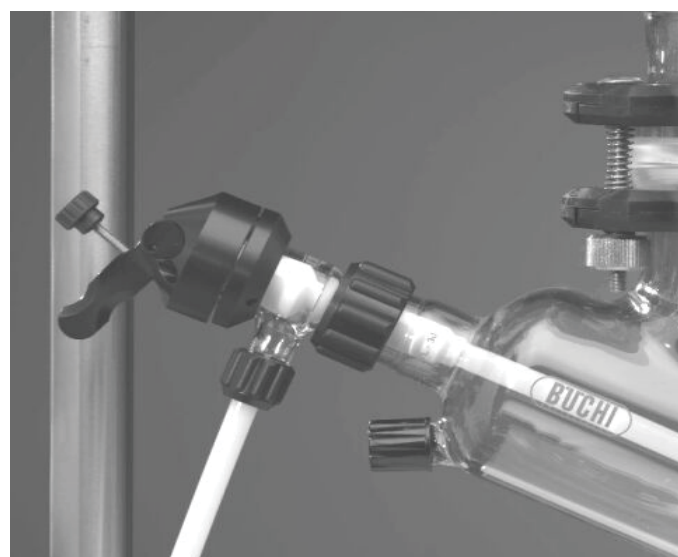
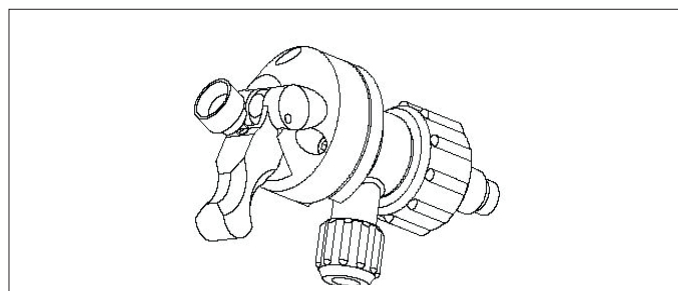

Fig. 4.15: Inlet tap

4.11 Operating the Inlet Valve

The inlet valve is also closed by an integrated spring, which applies contact pressure between the PTFE and the ground-glass joint. The valve can be opened and closed by operating the lever manually. The setting screw on the lever permits precise continuous metering or venting.

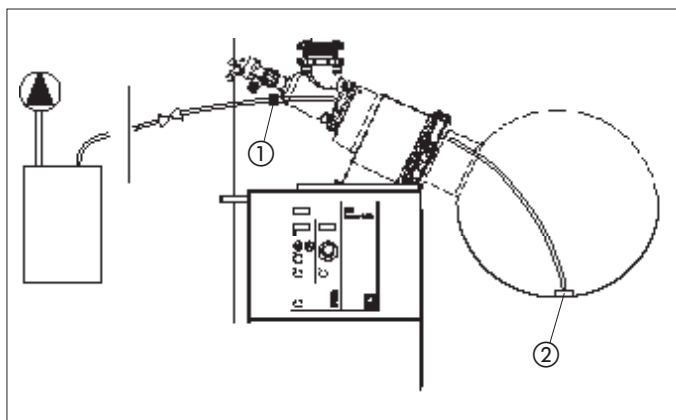

Fig. 4.16: Flask suction (diagram)

4.12 Flask Suction (Optional)

- A 10 mm dia. PTFE hose is routed from the inside through the SVL 15 threaded opening ① on the distributor head and the threaded connection is tightened.
- The hose is then positioned by inserting it into the evaporating flask.



Fig. 4.17: Positioning the tip of the hose with the magnet

- A PTFE enclosed magnet ② is fitted to the front tip of the hose. A second magnet ③ is moved from the outer surface of the flask towards the tip of the hose until the magnets attract each other.
- By moving the outer magnet, the hose can be guided to any position in the flask and the entire contents can be siphoned off so that nothing remains in the flask.
- The hose is connected to a container and this is connected to a vacuum source. (Not included in the scope of delivery.)

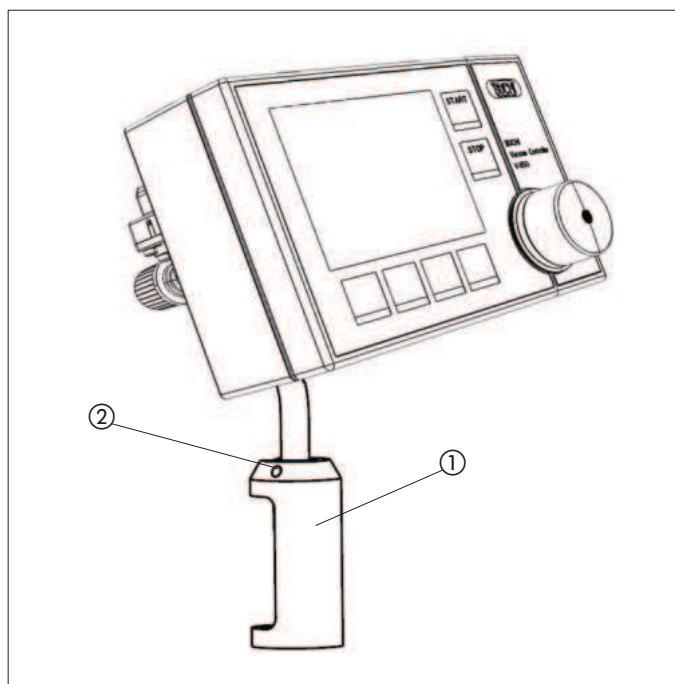

Fig. 4.18: Installation of the vacuum controller

4.13 Vacuum Controller (Accessory)

The process is carried out under vacuum to optimize evaporation. The V-850/855 vacuum controller is most suitable for control.

Installation of the vacuum controller

- Screw the support ① onto the upper surface of the housing.
- Secure the retaining rod by inserting the side socket head cap screws ② into the retainer.
- Fit the vacuum controller on the retaining rod.
- Connect the cables and hoses as described in the next Chapter.
- The hoses are routed from vacuum connection GL 14 at the glass assembly (descending) or from a T-piece in the hose (reflux) to the vacuum controller via a Y-connection and to the pressure indicator on the front panel.

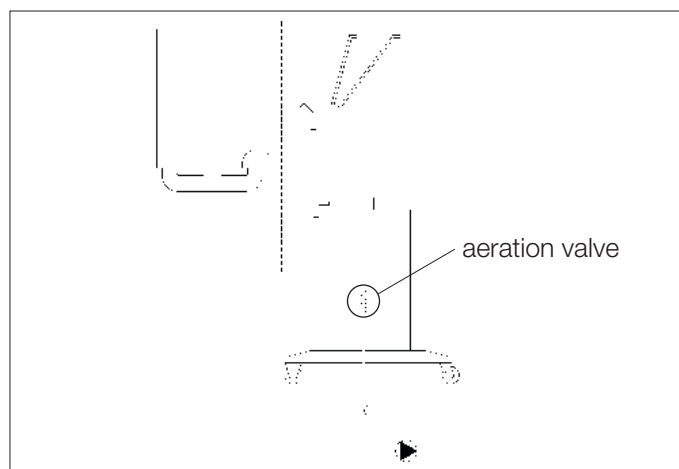

Fig. 4.19: Vacuum hoses

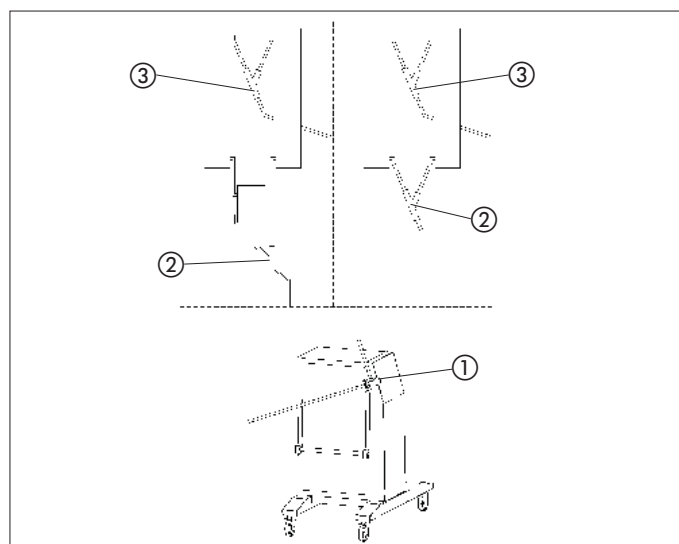

Fig. 4.20: Cooling water hoses

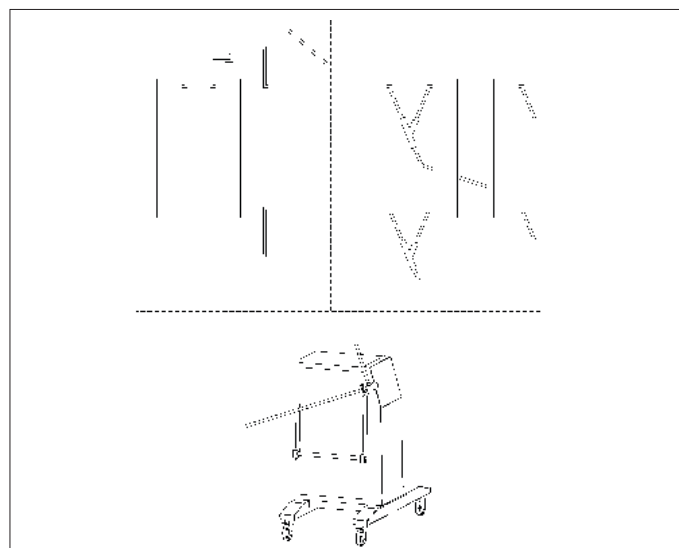

Fig. 4.21: Cooling water hoses: versions with third cooler

4.14 Connections to the Vacuum and Cooling Medium

Vacuum

The Rotavapor R-250 is connected to the vacuum source on the rear panel. The vacuum hose is then routed from the venting valve (inside the unit) to the condensation unit.

For the reflux set-up both condensers are connected to the hose via a Y-piece.

In the case of the descending glass assembly the vacuum hose is connected at the vacuum connector or at the third cooler.

Cooling medium

The cooling medium is connected at the valve fittings ①. The flow is adjusted by means of the tap. In the case of the reflux glass assembly, the distillate cooler is connected to one cooler from the valve ① via Y-piece ② and the second cooler is connected in parallel. Finally, the two condensers are connected via a Y-piece ③ and the cooling medium is returned at the wide hose nipple.

In the case of the descending glass assembly, the cooling medium is distributed between the two condensers from the valve via a Y-piece ② and is then returned via a second Y-piece ③.

A list of the supplied hoses with Part Numbers can be found in Chapter 8.6.

If a third cooler fitted downstream is used, it is connected in parallel across a special water distributor head. A second cooling circuit at a lower temperature can also be used so that the third cooler becomes a cold trap.



4.15 Heating Medium

Never operate the heating bath when there is no heating medium in it!

Suitable heating media include:

- Water (some Borax should be added when using deionized water).
- Heat transfer oils suitable for use at temperatures up to 160° C (e.g., Ucon HTF 14, Fluka AG).
- Water-soluble polyethylene glycol (e.g., Polyethylene glycol 600, Fluka AG).



After the oil bath has been standing opened for a prolonged period, condensation water can collect on the bottom. When the bath is used again, it must be heated above 100°C with rotating flask in order to drive the water out.

4.16 Checking the Installation

After installation has been completed and before running the first distillation, check to make sure that the installation has been carried out correctly.

- Inspect the glass for possible damage.
- Check that all connections (cooling medium, vacuum) have been fixed properly in position.
- Check that the flask is securely mounted and cannot be moved at the snap flange coupling.
- Check for leaks in the vacuum system (see Chapter 6, Maintenance).
- When the unit is switched on, the version of the software is displayed and a visual check is made to ensure that all controls that illuminate are in proper working order.

5 Operation

Make sure that the unit has been commissioned properly as described in Chapter 4.

5.1 Layout of Operating and Display Elements



Fig. 5.1: Operating unit of the R-250

- ① Main breaker switch
- ② Lift for the bath
- ③ Rotation ON/OFF
- ④ Rotating speed adjustment
- ⑤ Rotating speed display
- ⑥ Heater ON/OFF
- ⑦ Input: Set-point temperature for bath
- ⑧ Temperature UP/DOWN
- ⑨ Display for bath temperature
- ⑩ Display for vapour temperature
- ⑪ Aeration

When the unit is switched off or in the event of a power failure, the bath can be lowered automatically so that the evaporating flask is always separated from the source of heat.

5.2 Setting the Maximum Setpoint Temperature and Lowering the Bath Automatically

Setting the Maximum Setpoint Temperature

- Press the button “SET TEMP” ⑦, simultaneously switching on the main breaker switch ①. This activates the input for setting the maximum set-point temperature.
- The value can be set at any level desired by pressing the “DOWN” and “UP” buttons ⑧.
- The input is stored and the unit switched into the operating mode only after the “AERATE” button ⑪ is then pressed.

Adjusting the Optional Automatic Lowering of the Bath

- Press the button “LIFT down” ②, simultaneously switching on the main breaker switch ①. This results in the display “ON” or “OFF”.
On = The lift lowering has been switched ON
Off = The lift lowering has not been switched ON.
- To switch back and forth between ON and OFF, press repeatedly on the button “LIFT down” ②.
- The input is stored and the unit switched into the operating mode only after the “AERATE” button ⑪ is then pressed repeatedly.



If the option is activated, the bath is automatically lowered when the equipment is switched on. This ensures that, if there is a short power failure, the bath will be lowered.

5.3 Selection of Distillation Temperature

In order to attain optimum distillation conditions, the energy supplied to the distillation from the bath must be dissipated again across the cooler. In order to ensure this, it is best to work according to the following rule of thumb:

Cooling water	ΔT_2	Boiling temperature	ΔT_1	Bath
max. 20 °C		40 °C		60 °C

How do you attain these conditions?

- Set the bath temperature at 60 °C.
- Adjust the cooling water. Its temperature should not be higher than 20 °C.
- Allow the cooling water to flow through the cooler at a rate of about 120–150 liters/hr.
- Select the working vacuum so that the boiling point of the solvent is at 40 °C.
- Obtain the corresponding value for the vacuum from the Table of solvents.

Advantages of a Bath Temperature of 60 °C

- Evaporating flasks can be changed without any danger of scalding.
- The rate of water evaporation out of the heating bath is not yet very high.
- The energy in the heating bath is being utilized very efficiently.

The solvent should condense out in approx. 2/3 to 3/4 of the lengths of the cooling coils present.

5.4 List of Solvents

Solvent	Formula	Molar Mass in g/mol	Evaporation Energy in J/g	Boiling Point at 1013 mbar	Spec.Gravity in g/cm³	Vacuum in mbar for a Boiling Point at 40°C
Acetic acid	C ₂ H ₄ O ₂	60.0	695	118	1.049	44
Acetone	C ₃ H ₆ O	58.1	553	56	0.790	556
n-Amyl alcohol, n-Pentanol	C ₅ H ₁₂ O	88.1	595	137	0.814	11
Benzene	C ₆ H ₆	78.1	548	80	0.877	236
n-Butanol, tert. Butanol	C ₄ H ₁₀ O	74.1	620	118	0.810	25
(2-Methyl-2-Propanol)	C ₄ H ₁₀ O	74.1	590	82	0.789	130
Carbon tetrachloride	CCl ₄	153.8	226	77	1.594	271
Chlorobenzene	C ₆ H ₅ Cl	112.6	377	132	1.106	36
Chloroform	CHCl ₃	119.4	264	62	1.483	474
Cyclohexane	C ₆ H ₁₂	84.0	389	81	0.779	235
Diethyl ether	C ₄ H ₁₀ O	74.0	389	35	0.714	850
1,2,-Dichlorethane	C ₂ H ₄ Cl ₂	99.0	335	84	1.235	210
1,2,-Dichlorethylene (cis)	C ₂ H ₂ Cl ₂	97.0	322	60	1.284	479
1,2,-Dichlorethylene (trans)	C ₂ H ₂ Cl ₂	97.0	314	48	1.257	751
Diisopropyl ether	C ₆ H ₁₄ O	102.0	318	68	0.724	375
Dioxane	C ₄ H ₈ O ₂	88.1	406	101	1.034	107
DMF (Dimethylformamide)	C ₃ H ₇ NO	73.1		153	0.949	11
Ethanol	C ₂ H ₆ O	46.0	879	79	0.789	175
Ethyl acetate	C ₄ H ₈ O ₂	88.1	394	77	0.900	240
Heptane	C ₇ H ₁₆	100.2	373	98	0.684	120
Hexane	C ₆ H ₁₄	86.2	368	69	0.660	335
Isoamyl alcohol, 3-Methyl-1-Butanol	C ₅ H ₁₂ O	88.1	595	129	0.809	14
Isopropyl alcohol	C ₃ H ₈ O	60.1	699	82	0.786	137
Methanol	CH ₃ O	32.0	1227	65	0.791	337
Methylene chloride, Dichloromethane	CH ₂ Cl ₂	84.9	373	40	1.327	850
Methylethylketon	C ₄ H ₈ O	72.1	473	80	0.805	243
Pentachlorethane	C ₂ HCl ₅	202.3	201	162	1.680	13
Pentane	C ₅ H ₁₂	72.1	381	36	0.626	850
n-Propyl alcohol	C ₃ H ₈ O	60.1	787	97	0.804	67
1,1,2,2,-Tetrachloroethane	C ₂ H ₂ Cl ₄	167.9	247	146	1.595	35
Tetrachloroethylene	C ₂ Cl ₄	165.8	234	121	1.623	53
THF (Tetrahydrofurane)	C ₄ H ₈ O	72.1		67	0.889	357
Toluol	C ₇ H ₈	92.2	427	111	0.867	77
1,1,1,-Trichlorethane	C ₂ H ₃ Cl ₃	133.4	251	74	1.339	300
Trichlorethylene	C ₂ HCl ₃	131.3	264	87	1.464	183
Water	H ₂ O	18.0	2261	100	1.000	72
Xylol (Mixture)	C ₈ H ₁₀	106.2	389			25
(o)				144	0.880	
(m)				139	0.864	
(p)				138	0.861	

Table 3: List of Solvents (CRC Handbook, 65th Ed)

5.5 Troubleshooting

Fault	Possible cause	Remedy
Bath is not lifted	No power supply for bath lift, control defective	Contact service department
	Bath lift defective	Contact service department
Heating does not operate	Over-temperature protection has been activated	Reset over-temperature protection
	PT-1000 defective (Error E0)	Check PT-1000 in the bath and contact service department
Heating does not operate, "Overtemp." LED illuminates	1) Switching relay defective or 2) Setpoint temperature reset by more than 15°C	1) Contact service department 2) Wait until bath has cooled down, switch off via unit, confirm
	Heater coils defective	Contact service department
Rotation does not function	Rotary drive defective	Contact service department
	Rotary drive overheated	Allow it to cool off and then start it up again
No vapor temperature	Temperature sensor not inserted correctly or defective	Check PT-1000 plug-and-socket connection, contact service department

Table 4: Troubleshooting

5.6 Reset of the over-temperature protection



Fig. 5.2: Resetting the over-temperature limiter

If the heater heats up over 205°C (e.g. if no heating medium is in the bath), it is cut off by a mechanical overtemperature protection. The overtemperature protection is reset by pushing the button under the heating block.

5.7 Error Messages

Error messages indicate a defect on the unit and are signalled on the bath temperature display. They appear with an “E” at the start, followed by a specific number:

E0 :	Message:	Output from the bath sensor not within the valid range.
	Cause:	Sensor defective or a short-circuit has occurred.
	Action:	The bath heater is switched OFF. The bath is lowered. Rotation stops.
	Acknowledgment:	Switch the unit OFF.
E2 :	Message:	The bath is not reaching the intended maximum height.
	Cause:	The motor is defective or blocked. No voltage.
	Action:	The lift motor switches OFF. Rotation and heating continue.
	Acknowledgment:	Switch the unit OFF.
E3 :	Message:	The rotary drive does not reaching the required speed, or is turning too quickly.
	Cause:	Drive defective. Mechanical blocking. No power. Semi-conductor relay defective.
	Action:	Bath heater is switched OFF. Bath is lowered.
	Acknowledgment:	Switch the unit OFF.
E4 :	Message:	Battery voltage too low. Displayed only when starting the unit.
	Cause:	PB battery defective
	Action:	None
	Acknowledgment:	Press any button.
E5 :	Message:	EEPROM error.
	Cause:	Hardware defect.
	Action:	None.
	Acknowledgment:	Press any button. Work can then be continued, but a Service technician must be notified of the problem.
E6:	Message:	Overload of the valve output
	Cause:	Valve defective or wrong connections
	Action:	None.
	Acknowledgment:	Switch the unit OFF
E27 :	Message:	Communication with control panel broken.
	Cause:	Cables or plugs defective.
	Action:	Heder and Rotation are switched off, bath lowers.
	Acknowledgment:	Switch the unit off.
E28 :	Message:	Replay of heater down.
	Cause:	Overtemperature cutoff is active.
	Action:	Heder and Rotation are switched off, bath lowers.
	Acknowledgment:	Reset the overtemperature cutoff. (see chapter 5.5)

Table 5: Error messages



To let all possible error messages appear, the device must be shut off and on at least once per 24 h.

6 Maintenance

Please note all rules aimed at keeping the rotary evaporator in a functional condition. These also include periodic cleaning and inspection for any damage that might have occurred.



Make certain that supply of power to the unit has been interrupted before doing any maintenance work on the unit. Always support the bath from below, on the underside of the bath whenever doing any repair work.

6.1 Cleaning

Use commercially available cleaning agents to clean the glassware.

Merely wipe the housing off with a damp cloth (without using any organic solvents).

Use a commercially available de-liming agent to dissolve residues of lime in the bath and flush the bath out well.

Vacuum seal

The vacuum seal should be cleaned according to how much it is used but every three months as a minimum. See Chapter 6.5 for instructions on how to remove it.

Wipe the sealing lip with a soft dry cloth. Clean the contact surface of the vapor duct.



Regular care of the seal extends its service life.



Fig. 6.1: Taking apart the snap flange coupling

6.2 Dismantling/Assembling the Flask Snap Flange Coupling

Dismantling the snap flange coupling

- Close the two segments of the snap flange coupling.
- Turn the snap flange coupling by 180°, until the closure faces down.
- Have Tool No. 20075 ready at hand.
- Reopen the closure.
- Lift the 1st segment of the snap flange coupling to open it.
- Lift the 2nd segment of the snap flange coupling to open it.
- With three fingers at the tip, reach under the middle segment and raise it up.
- Insert Tool No. 20075 in at the side, between the lugs on the positional lock. Turn lightly until the pin becomes unlatched. Take the snap flange coupling assembly off.
- Clean the snap flange coupling.



Fig. 6.2: Assembling the snap flange coupling

Assembling the snap flange coupling

- Insert the snap flange coupling from above, until the pins in the lock latch into the hole on the lug.
- Close the two segments of the snap flange coupling.
- Turn the snap flange coupling again by 180°, until the closure lies at the top.
- Lift the two segments of the snap flange coupling to open them.



Fig. 6.3: Removing the evaporating flask seal

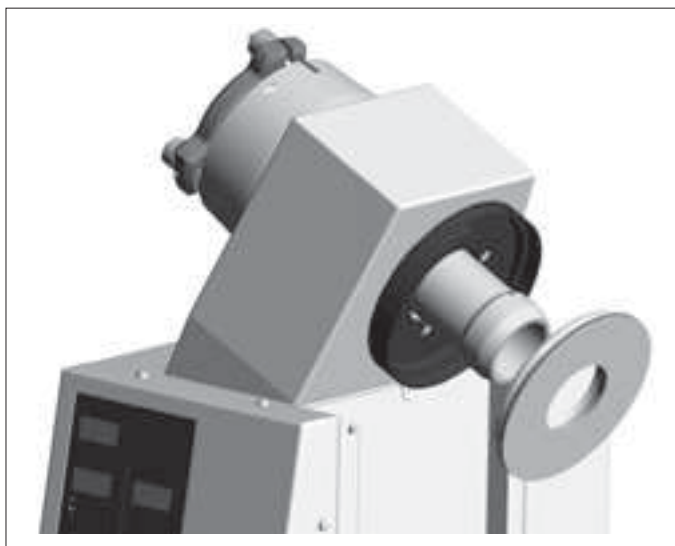

Fig. 6.4: Inserting the evaporating flask seal

6.3 Removing/Inserting the Evaporating Flask Seal

Removing the evaporating flask seal

- Seal the holder for the seal by 180°, until the opening faces up.
- Take hold of the seal with both hands, from above and from the front, and pull it out slowly.
- Tilt the seal slightly and carefully pull it all the way out. Be careful not to damage the glass centering bulge when doing so.
- Remove the vapor duct.

Inserting the evaporating flask seal

- Insert the vapor duct.
- Insert the seal. Using gentle pressure, shove it across the lock preventing it from twisting out of position, and then shove it all the way in. Press it with both thumbs until it latches in position.

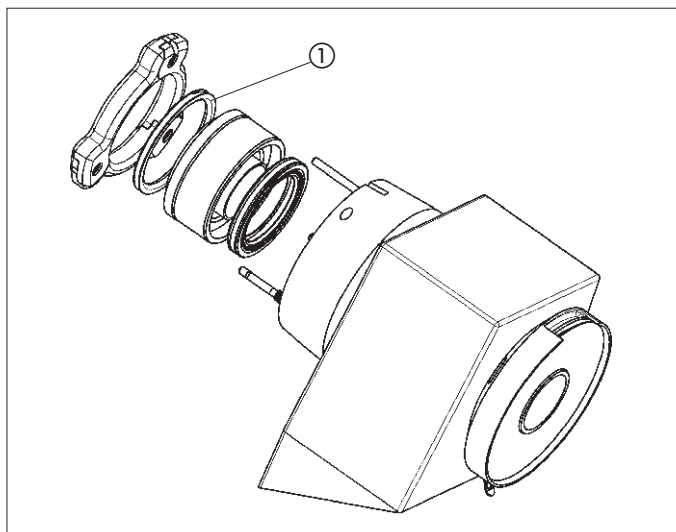

Fig. 6.5: Replacing the seal in the distribution head

6.4 Changing the Seals on the Distribution Head

- Open the DN70 EasyClamp by releasing the knurled nuts on all 3 bolts, but do not screw the nuts completely off.
- Tilt the top bolt out toward the back.
- Open the upper and lower EasyClamp segments and carefully lift the distribution head off the glass assembly.
- Take out the seal ① laid in at the front and replace it.

6.5 Installing and Removing the Vacuum Seal

During the running-in phase, which lasts approx. 10 hours, the seal may show signs of increased wear. This is normal for a PTFE seal.

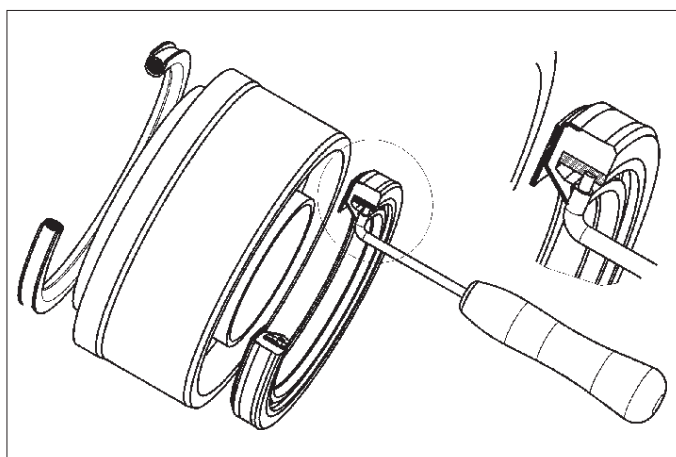

Fig. 6.6: Taking out the Vacuum Seal

- Remove the DN70 EasyClamp completely and take off the distribution head.
- Pull the cylindrical seal holder out and turn it over.
- Insert Tool No. 20075 into the metal guide on the seal and pull the seal out.
- Put in the new seal with the dark scraper ring facing the inside and the metal guide ring facing outward.
- Insert the cylinder with the seal at the back lying on the in-side.
- Insert the seal at the front.
- Provisionally install the EasyClamp using 2 bolts.
- Set the distribution head of the glass assembly on top of the seal.
- Close the segments of the EasyClamp. Flip the top bolt up and in, and hand-tighten all 3 knurled nuts.

The unit should be tested for leaks each time the vacuum seal has been removed.

6.6 Testing for Leaks

With the assembled rotary evaporator in a clean and dry condition, test it to ensure that the vacuum system is free of leaks. To do this, evacuate the unit to below 100 mbar and then close the vacuum line. The rate of pressure rise must not exceed 10 mbar per 10 minutes.

A greater pressure rise indicates a leakage. In such a case, recheck all EasyClamp connections and all valves.

6.7 Customer Service

No intervention on or in the unit is permissible except when done by authorized Service personnel. These are individuals with a well-backed technical professional training and knowledge of the dangers that result from a failure to observe the safety precautions required. BÜCHI's Customer Service representatives have available to them a Service Manual specific to the unit in question. That manual is issued only to authorized Service personnel.

The addresses of BÜCHI's official Customer Service representatives are shown on the back cover of this Operation Manual. Please turn to these representatives should you have any malfunctions, technical questions, or problems in using the unit.

BÜCHI's Customer Service Dept. will be ready and happy to offer the following services:

- Spare parts service
- Repair service
- Maintenance service
- Technical consultation.

7 Taking out of Operation



Remove all hazardous materials and clean the unit thoroughly. This prevents any risk that individuals could suffer injuries due to contact with hazardous materials.

7.1 Storage

Always store the unit and spare parts for it in a clean and dry location.

7.2 Packing / Transport

The original packing has been specially designed for transporting the unit and the glass parts for it. Use only the original packing materials for any further transport.

7.3 Waste Disposal

Table 9 in the Appendix, Chapter 9, contains a list of the materials, including their material codes, used for the most important components of the unit. This list has been provided in order to enable environmentally correct disposal of the rotary evaporator. It ensures that the parts can be separated and sent for appropriate recycling. Please refer to the pertinent guidelines when disposing of electrical parts. In addition, observe all regional and local laws covering waste disposal.

Used batteries may be returned directly to your BÜCHI representative for disposal.

8 Spare Parts and Accessories

Only original BÜCHI accessories and spare parts ensure safe operation and a proper functioning of the unit. The use of spare parts and accessories other than those from BÜCHI is permissible only with prior approval of the manufacturer. The Spare Parts Catalog may be used for purposes of assembly and disassembly only in conjunction with the corresponding Chapters 4 and 7 in this Operation Manual. Disclosure and distribution to third parties, and manufacturing based on this manual are strictly forbidden.

Copyright by BÜCHI Labortechnik AG. All rights reserved.

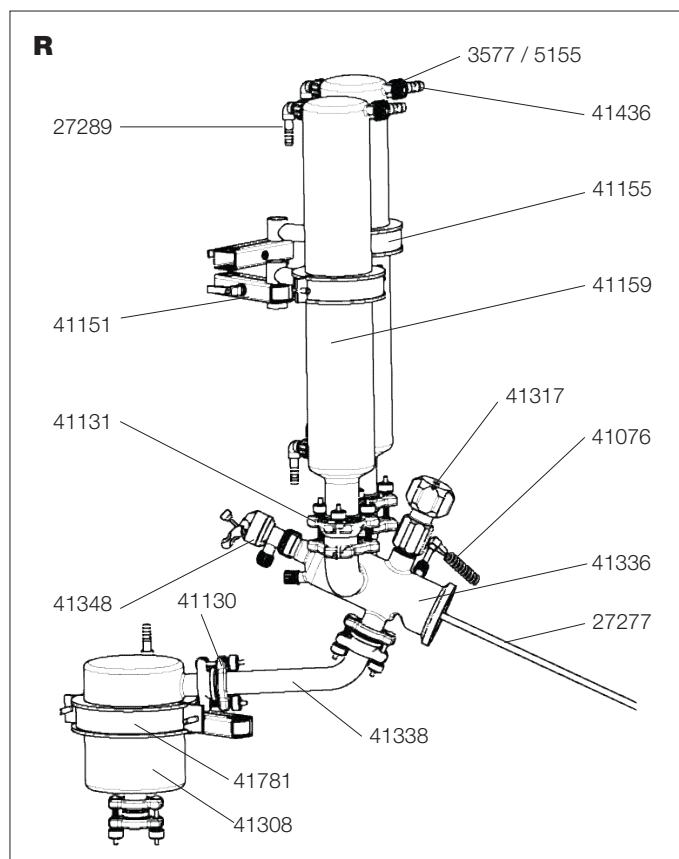
8.1 Spare Parts, Glass Assemblies R, RB

Component	Ordering No.
Threaded sleeve Svl 22	03577
Seal Svl 22 Id 17 PTFE	05155
PTFE hose, Outer Diam. 10.0x1.0	27277
Screwed fitting Svl 22	27289
Cooler Bullfrog, closed, PLG	27824
Temperature sensor B, complete	41076
Glass holder B, complete	41120
EasyClamp, DN25	41130
EasyClamp, DN40	41131
Pivoting clamp, complete	41151
Glass holder, complete	41155
Cooler, 3-coil, closed PLG	41159
Set of bolts for EasyClamp, DN25	41240
Set of bolts for EasyClamp, DN40	41241
Distillate cooler PLG	41308
Industrial tap, large	41060
Distribution piece "R" PLG	41336
Connection DN 25 PLG	41338
Inlet valve, complete	41348
Hose nipple	41436
Glass holder, distillate condenser	41781

Table 6: Spare parts, Glass Assemblies R, RB

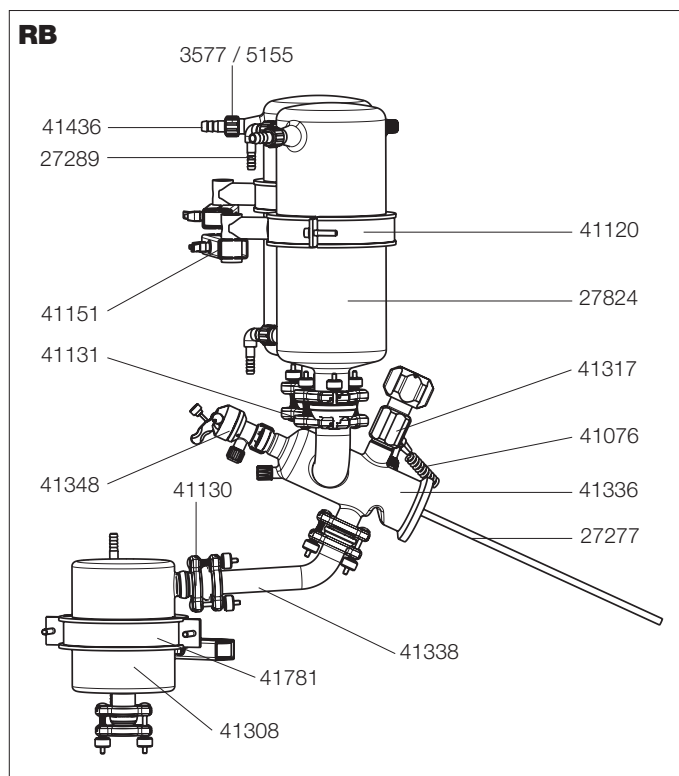
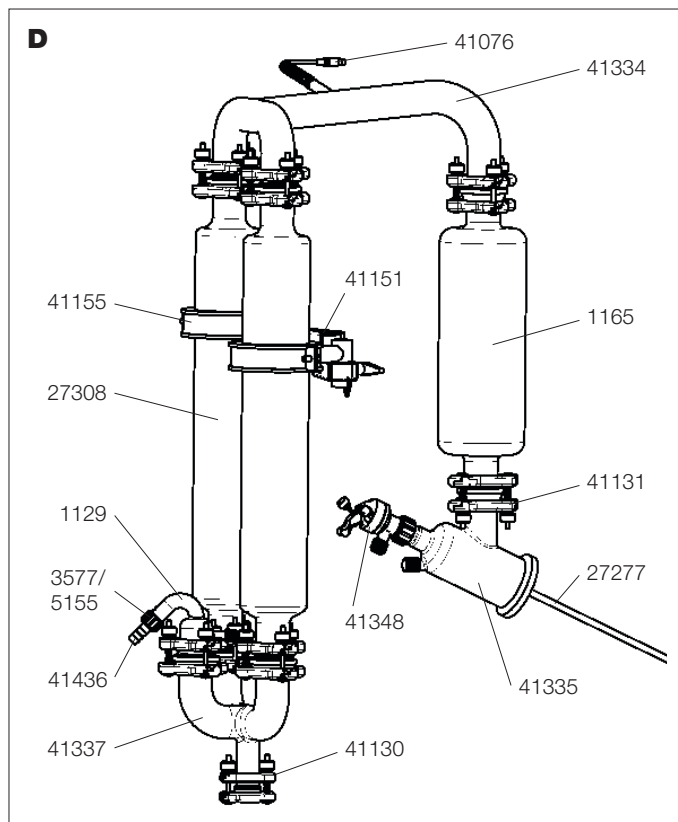

Fig. 8.1: Spare parts: Reflux glass assembly

8.2 Spare Parts, Glass Assemblies D, D3



Component	Ordering No.
Vacuum connector PLG	01129
Expansion vessel PLG	01165
Threaded sleeve Sv1 22	03577
Seal Sv1 22 Id 17 PTFE	05155
PTFE hose, Outer Diam. 10.0x1.0	27277
Screwed fitting Sv1 22	27289
Cooler, 3 coil PLG	27308
Temperature sensor B, complete	41076
EasyClamp, DN25	41130
EasyClamp, DN40	41131
Pivoting clamp, complete	41151
Glass holder, complete	41155
Cooler, 3-coil, closed PLG	41159
Set of bolts for EasyClamp, DN25	41240
Set of bolts for EasyClamp, DN40	41241
U-frame PLG	41334
Distribution piece "D" PLG	41335
Frame DN25/3xDN40 PLG	41337
Inlet valve, complete	41348
Hose nipple	41436
Extension	41270

Table 7: Spare parts, Glass Assemblies D, D3

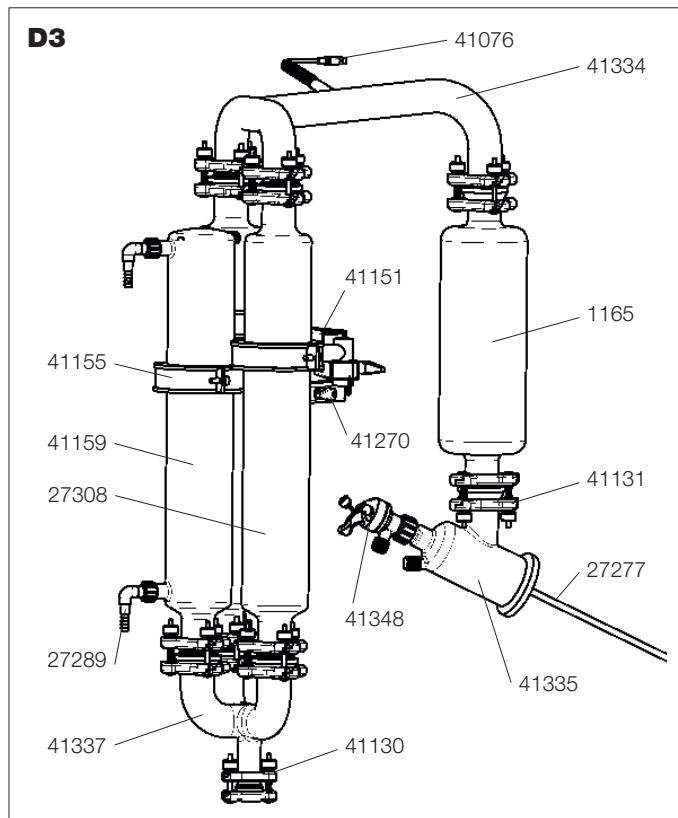

Fig. 8.2: Spare parts: Descending glass assembly

8.3 Spare Parts, Drip Tray**Component****Ordering No.****Single receiver**

EasyClamp, DN25	41130
Industrial tap, small	41062
Spindle support	41353
Angle seat valve, special	41405
Receiving flask 20 lt. PLG	41446
Branching piece R-250 PLG	41475
Ventilation duct, complete	41480

Interchangeable receiver

Branching piece 1 PLG	41048
EasyClamp, DN25	41130
Industrial tap, small	41062
Spindle support	41353
Angle seat valve, special	41405
T-piece DN 3x40 PLG	41445
Receiving flask 20 lt. PLG	41446
Ventilation duct, complete	41480

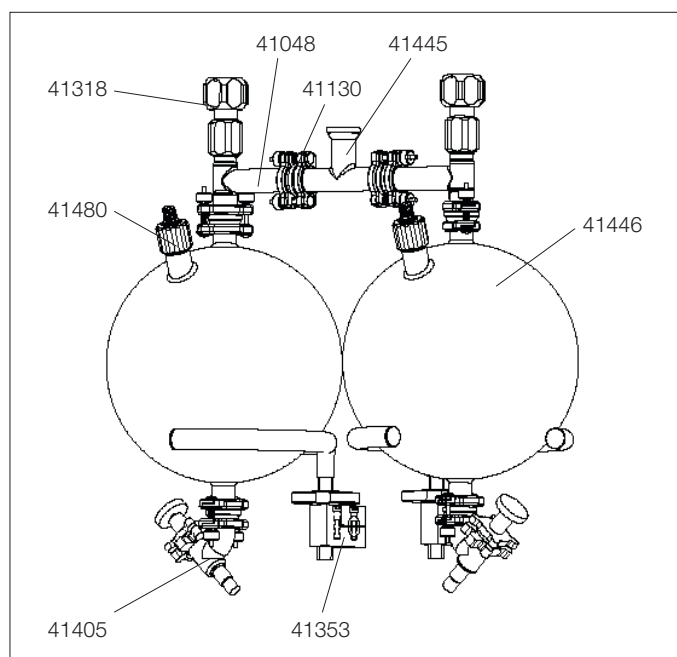
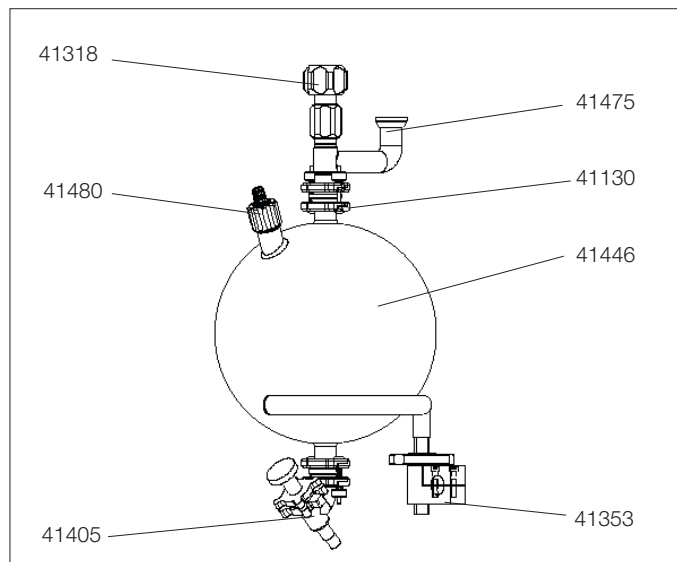

Fig. 8.3: Spare Parts: Drip tray

8.4 Seals, Tools

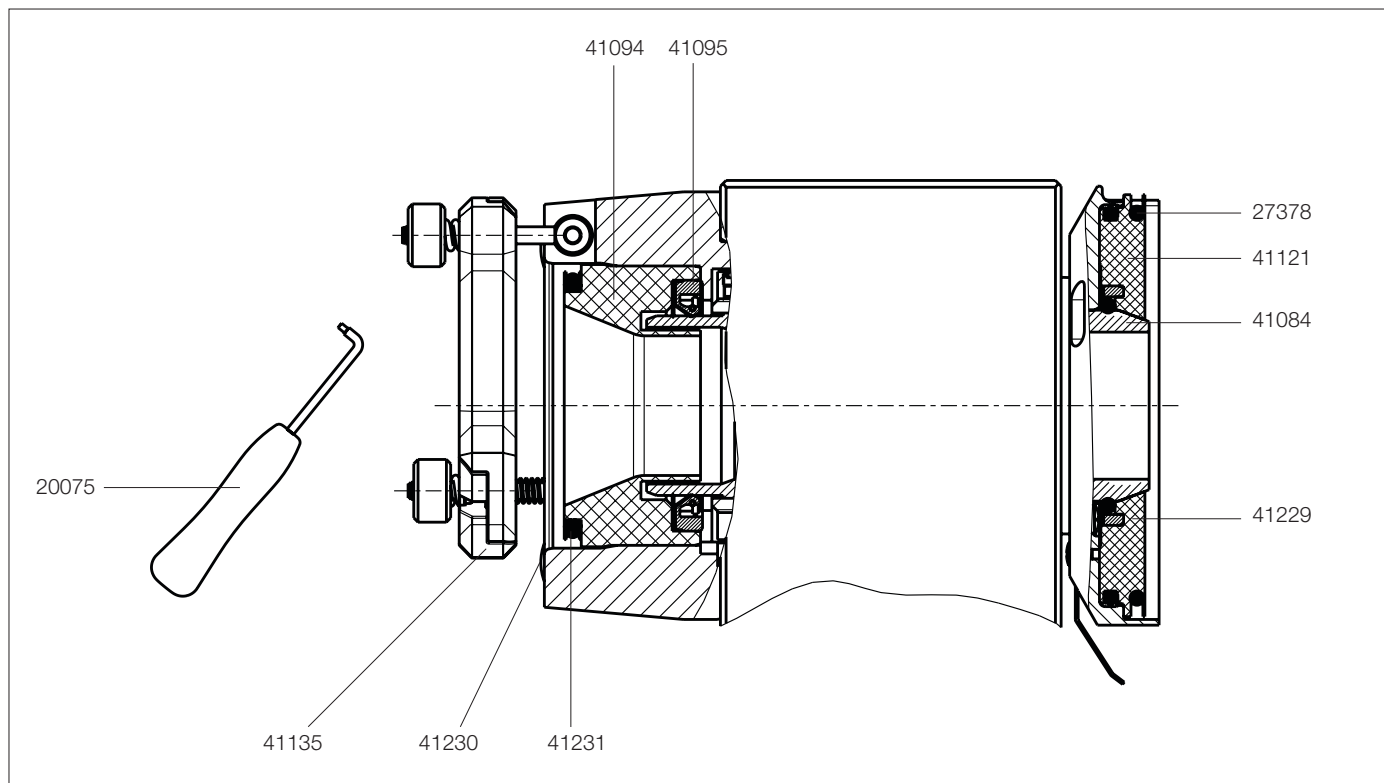

Fig. 8.4: Sealing elements

Component

Ordering No.

Sealing elements

Support ring inlet valve	41147
Seal SVL 30	00398
Screw Cap SVL 30	03223
Screw Cap SVL 15	03549
Seal tool	20075
O-ring 130x5.0 Fpm70	27378
Vapor duct	41084
Seal holder	41094
Vacuum seal	41095
Evaporating flask seal, complete	41121
EasyClamp element, DN70	41135
Set of 5 O-rings 64x5.0	41229
Set of 10 cover caps, D11 Pa	41230
Set of distribution head sealings	41231
Glass body	41346
Inlet valve, complete	41348
Connection, PTFE	41354
PTFE bellow	41388
Set of 5 SVL 15 seals	41946

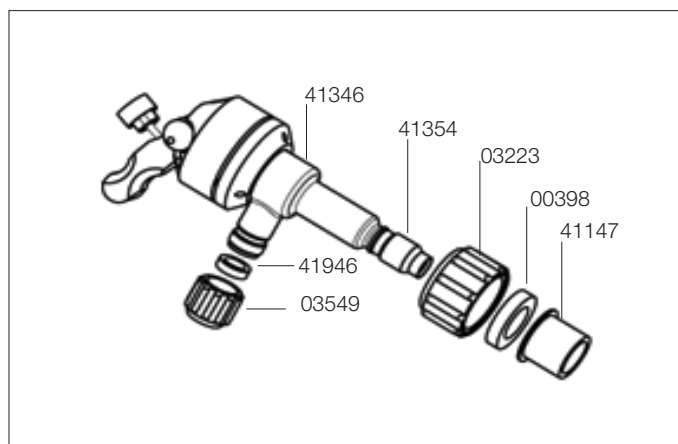

Fig. 8.5: Inlet valve, complete

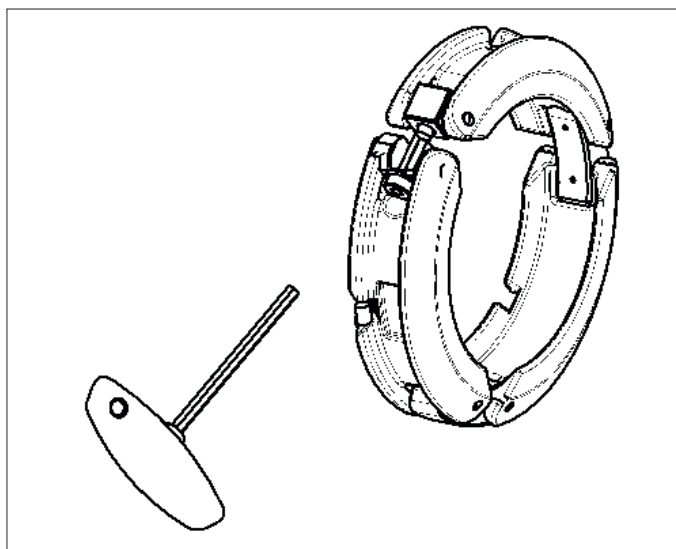

Fig. 8.6: Snap flange coupling complete with tool

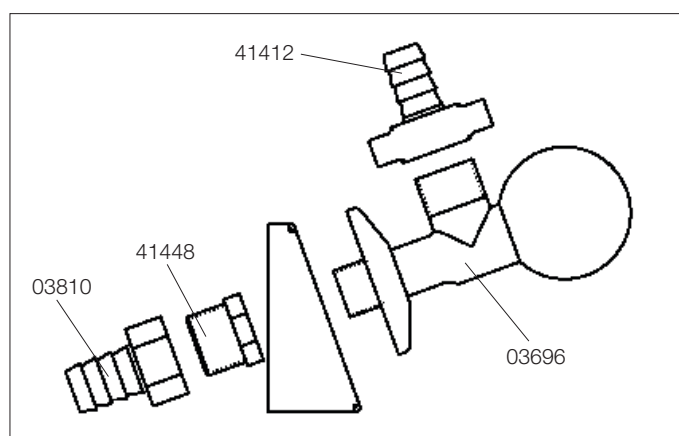

Fig. 8.7: Cooling water tap, complete

Component	Ordering No.
Snap flange coupling, complete	41415
Screw cap	41416
Tool	41472

Cooling water tap, complete	03693
Nipple $\frac{3}{4}$ " x 20 mm	03810
Nipple $\frac{3}{4}$ " x 16 mm	41412
Reducer $\frac{1}{2}$ " x $\frac{3}{4}$ "	41448



Cover for evaporating flask, PE	11057349
---------------------------------	-----------------

8.5 Accessories

Component

Ordering No.

Kolben

Evaporating flask 20 ltr.	41432
Evaporating flask 50 ltr.	41339

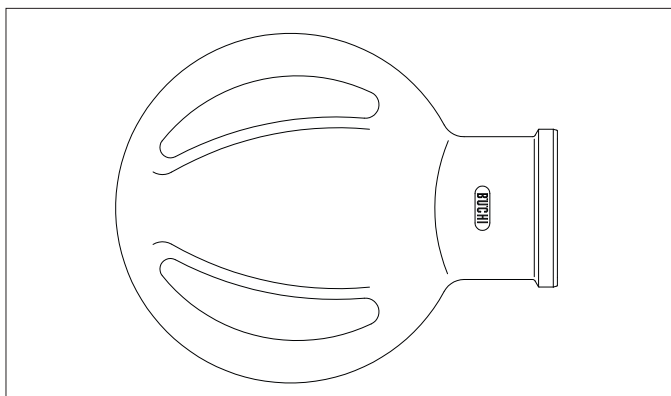
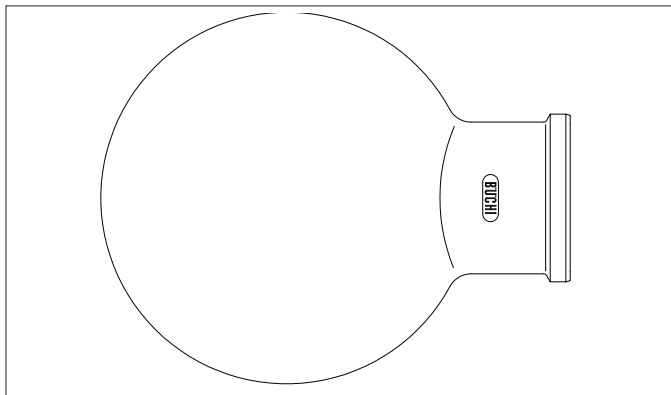

Drying flask 20 ltr.	41393
Drying flask 50 ltr.	41394

This special flask is particularly suited for drying powdery substances or a homogeneous mixture of solid products. The baffles attached on the circumference of the flask ensure an intensive circulation of the contents inside the flask.

Fig. 8.9: Flasks

Splash protection

Splash protection (cpl.)	41420
Replacement screen	41419

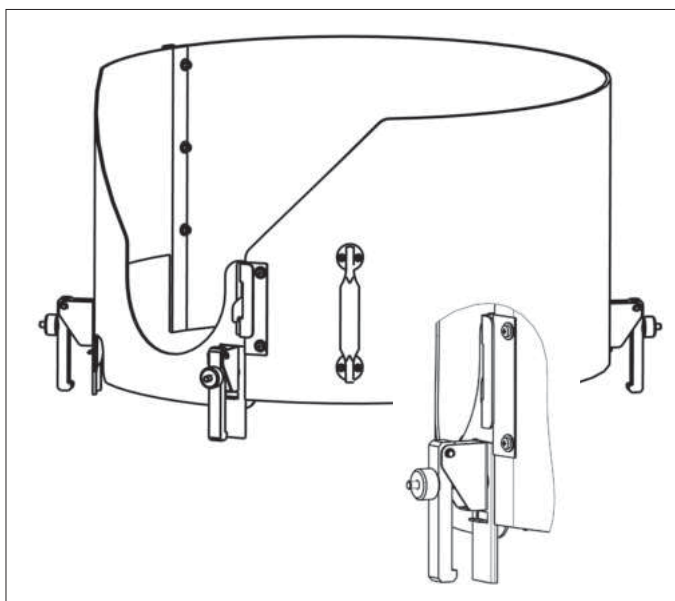

Installation

The mount is placed on the edge of the bath and secured with the lower clamp fitting

Fig. 8.10: Splash protection

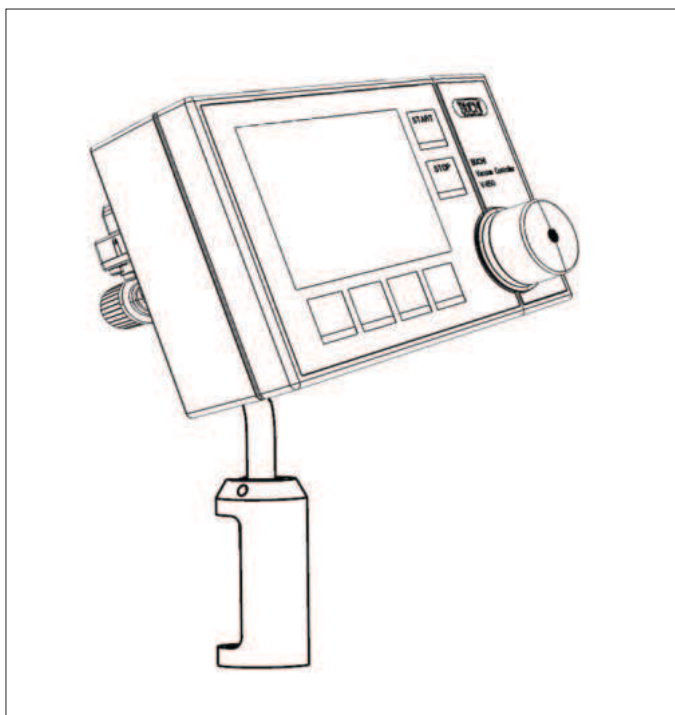

Fig. 8.11: Vacuum controller incl. support

Component	Ordering No.
-----------	--------------

Vacuum Controller	
--------------------------	--

V-850 for R-250	
------------------------	--

100 V - 230 V	47293
---------------	--------------

V-855 for R-250	
------------------------	--

100 V - 230 V	47292
---------------	--------------

Support	41465
---------	--------------

Rod	41426
-----	--------------

Communications cable (included in set)	40758
---	--------------

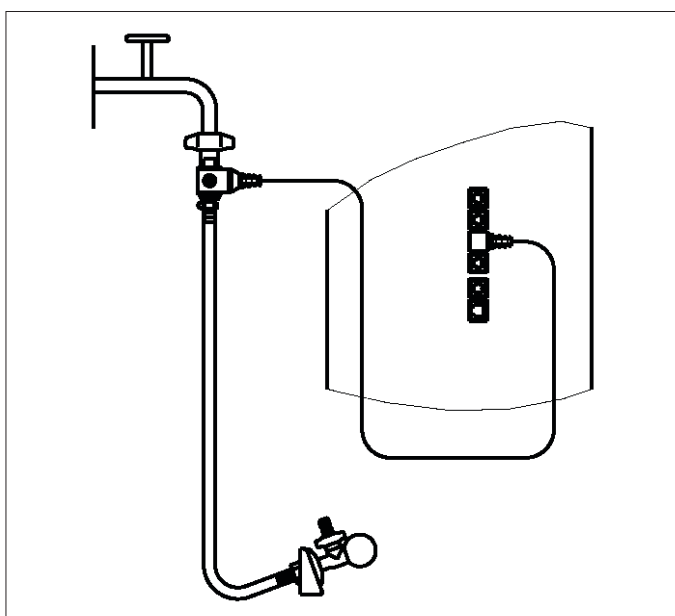

Fig. 8.12: Water valve

Water valve	
--------------------	--

An additional water valve can be used to switch the cooling water.

Water valve, complete	41191
-----------------------	--------------

Valve body	41263
------------	--------------

8.6 Hose Connections

Component	Ordering No.
Water:	
PVC hose, ID 10 mm	27146
PVC hose, ID 14 mm	17383
Y-piece, 12 mm / 16 mm	41473
Pressure side (upstream of reduction valve)	
Softaflex, ID 8 mm	04113
Softaflex, ID 19 mm	37617
Vacuum:	
Spiralflex hose, ID 16 mm	41441
Y-piece, Outer Diam. 16 mm	41449
T-reducer, 16 / 8 mm	41474
Product:	
PTFE hose, Outer Diam. 10 mm	27277

8.7 Connections to Rear Panel

Fig. 8.13: Connections to rear panel

Component	Ordering No.
Vacuum Controller V-850/855 for R-250	
Vacuum Controller V-850	47293
Vacuum Controller V-855	47292
Connections	
① Temperature probe	41076
② Control cable RJ45 2m	44989
③ Communications cable V-850/V-855	40758
④ Coolingwater valve	41191

9 Appendix

9.1 Technical Data

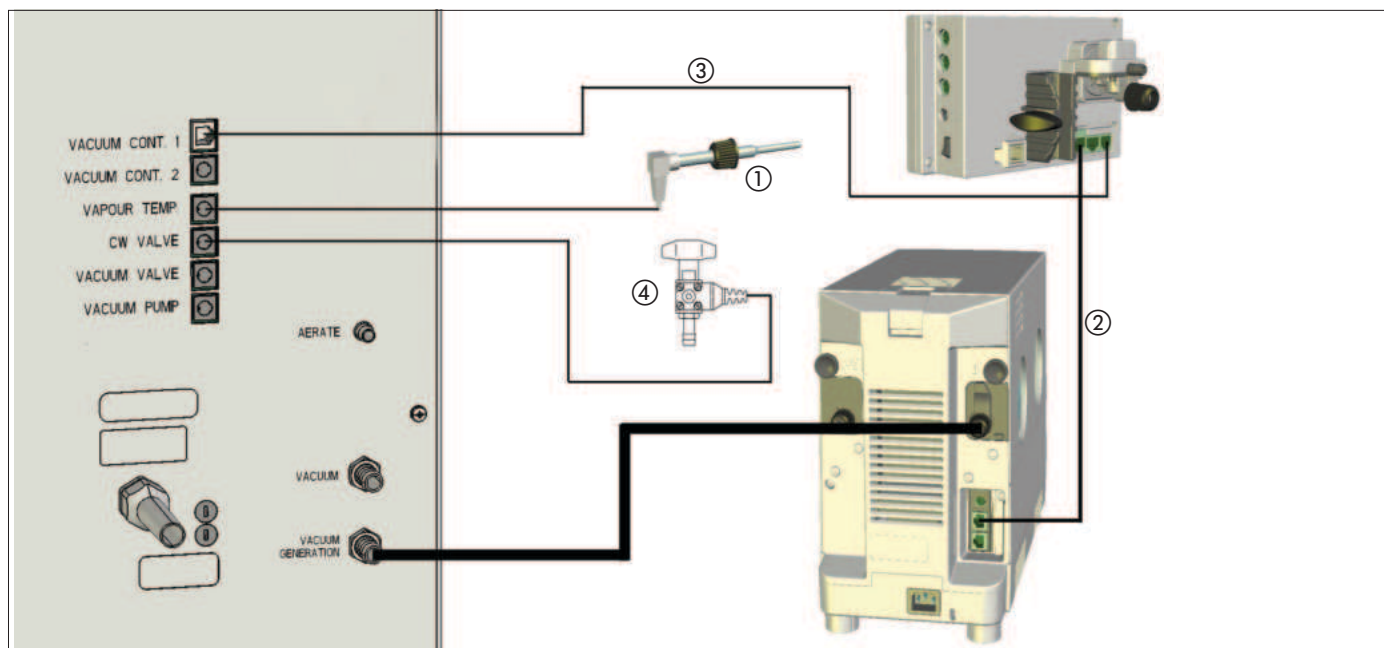
R-250

Power connection	7.5 kW
Connection voltage	400 – 440 V (3P +N), 50 / 60 Hz
Fuse (live, neutral)	T4 A L 250V (230V)
Site condition	maximum relative humidity 80% for temperatures up to 31° C decreasing linearly to 50% relative humidity at 40° C
Evaporator output	31 litres of acetone per hour, different for other solvents depending on the heat of evaporation
Rotation drive	Induction motor
Speed control	Frequency converter, 5-100 rpm
Bath output	6.6 kW, heat introduction <3W/cm ²
Bath dimensions	Diameter 610 mm, depth 320 mm
Bath pan	Stainless steel X2CrNiMo17 13 2 (1.4404 or 316L)
Bath heater control	Electronic, with PT-1000, control accuracy ± 2°C
Bath temperature range	0° - 180°C
Overheating protection	Separate monitoring circuit, mechanical reset facility, additional electronic back-up if the setpoint is exceeded by 15°C
Bath lift	Linear drive, IP 65
Battery	Battery, PB, 12V
Measurement of vapor temperature	PT-1000
Displays	Vapor temperature, bath temperature, rotary speed
Aeration	Integrated valve, vented in case of power failure or by button, with inert gas connection
Installation category	II
Degree of pollution	2
Cooling area	Two or three condensate coolers of 0,6 m ² each, distillate cooler 0,08 m ²
Vacuum pump	Recommended suction output in excess of 5 m ³
Cooling water consumption	200 – 400 l / h, 2,7 bar abs. maximum (without pulsation)
Weight	160 kg without glass
Dimensions	See relevant Chapter

Table 8: Technical Data

9.2 Materials Used

Part	Material	
	Description	Code
Chassis	X5CrNi 18 10	1,4301 or 304
Bath pan	X2CrNiMo 17 13 2	1,4404 or 316L
Glass	Borosilicate 3,3	
Seals	Polytetrafluorethylene	PTFE
Taps	Polytetrafluorethylene	PTFE

Table 9: Materials Used

BUCHI Affiliates:

Europe

Switzerland/Austria

BÜCHI Labortechnik AG
CH – 9230 Flawil
T +41 71 394 63 63
F +41 71 394 64 64
buchi@buchi.com
www.buchi.com

Italy

BUCHI Italia s.r.l.
IT – 20010 Cornaredo (MI)
T +39 02 824 50 11
F +39 02 575 12 855
italia@buchi.com
www.buchi.com/it-it

Benelux

BÜCHI Labortechnik GmbH
Branch Office Benelux
NL – 3342 GT Hendrik-Ido-Ambacht
T +31 78 684 94 29
F +31 78 684 94 30
benelux@buchi.com
www.buchi.com/bx-en

Russia

BUCHI Russia/CIS
Russia 127287 Moscow
T +7 495 36 36 495
russia@buchi.com
www.buchi.com/ru-ru

France

BUCHI Sarl
FR – 94656 Rungis Cedex
T +33 1 56 70 62 50
F +33 1 46 86 00 31
france@buchi.com
www.buchi.com/fr-fr

United Kingdom

BUCHI UK Ltd.
GB – Oldham OL9 9QL
T +44 161 633 1000
F +44 161 633 1007
uk@buchi.com
www.buchi.com/gb-en

Germany

BÜCHI Labortechnik GmbH
DE – 45127 Essen
T +800 414 0 414 0 (Toll Free)
T +49 201 747 49 0
F +49 201 747 49 20
deutschland@buchi.com
www.buchi.com/de-de

Germany

BÜCHI NIR-Online
DE – 69190 Walldorf
T +49 6227 73 26 60
F +49 6227 73 26 70
nir-online@buchi.com
www.nir-online.de

America

Brazil

BUCHI Brasil Ltda.
BR – Valinhos SP 13271-200
T +55 19 3849 1201
F +55 19 3849 2907
brasil@buchi.com
www.buchi.com/br-pt

USA/Canada

BUCHI Corporation
US – New Castle, DE 19720
T +1 877 692 8244 (Toll Free)
T +1 302 652 3000
F +1 302 652 8777
us-sales@buchi.com
www.buchi.com/us-en

Asia

China

BUCHI China
CN – 200233 Shanghai
T +86 21 6280 3366
F +86 21 5230 8821
china@buchi.com
www.buchi.com/cn-zh

India

BUCHI India Private Ltd.
IN – Mumbai 400 055
T +91 22 667 75400
F +91 22 667 18986
india@buchi.com
www.buchi.com/in-en

Indonesia

PT. BUCHI Indonesia
ID – Tangerang 15321
T +62 21 537 62 16
F +62 21 537 62 17
indonesia@buchi.com
www.buchi.com/id-in

Japan

Nihon BUCHI K.K.
JP – Tokyo 110-0008
T +81 3 3821 4777
F +81 3 3821 4555
nihon@buchi.com
www.buchi.com/jp-ja

Korea

BUCHI Korea Inc.
KR – Seoul 153-782
T +82 2 6718 7500
F +82 2 6718 7599
korea@buchi.com
www.buchi.com/kr-ko

Malaysia

BUCHI Malaysia Sdn. Bhd.
MY – 47301 Petaling Jaya,
Selangor
T +60 3 7832 0310
F +60 3 7832 0309
malaysia@buchi.com
www.buchi.com/my-en

Singapore

BUCHI Singapore Pte. Ltd.
SG – Singapore 609919
T +65 6565 1175
F +65 6566 7047
singapore@buchi.com
www.buchi.com/sg-en

Thailand

BUCHI (Thailand) Ltd.
TH – Bangkok 10600
T +66 2 862 08 51
F +66 2 862 08 54
thailand@buchi.com
www.buchi.com/th-th

BUCHI Support Centers:

South East Asia

BUCHI (Thailand) Ltd.
TH-Bangkok 10600
T +66 2 862 08 51
F +66 2 862 08 54
bacc@buchi.com
www.buchi.com/th-th

Middle East

BÜCHI Labortechnik AG
UAE – Dubai
T +971 4 313 2860
F +971 4 313 2861
middleeast@buchi.com
www.buchi.com

Latin America

BUCHI Latinoamérica S. de R.L. de C.V.
MX – Mexico City
T +52 55 9001 5386
latinoamerica@buchi.com
www.buchi.com/es-es

We are represented by more than 100 distribution partners worldwide.
Find your local representative at: www.buchi.com