



LAB Online Exhibition



Table of Contents

1	Scope of Delivery	2
1.1	Büchi Vac V-500	2
1.2	Büchi Vac V-501	3
1.3	Büchi Vac V-502	4
1.4	Büchi Vac V-503	5
2	Safety	6
3	Function	9
3.1	Büchi Vac V-500	9
3.2	Büchi Vac V-501	10
3.3	Büchi Vac V-502	11
3.4	Büchi Vac V-503	12
4	Putting into Operation	14
4.3	Büchi Vac V-500	15
4.4	Büchi Vac V-501	15
4.5	Büchi Vac V-502	16
4.6	Büchi Vac V-503	17
4.7	V-500 with more Vacuum Controllers V-800	18
5	Operation	19
6	Maintenance	22
7	Putting out of Operation	28
8	Spare Parts	29
9	Appendix	31



Please read these operating instructions carefully before using the **BÜCHI Vac V-500/501/502/503**. Keep these instructions in the proximity of the device so that you can consult them immediately whenever necessary. Chapter 2 contains important safety instructions. Read them carefully; they are essential for the safe operation of the device.

Technical changes may be made without prior notice. These operating instructions may not, either wholly or in part, be reproduced or rewritten by the use of electronic or optical systems, copied, or distributed without the express written permission of the firm BÜCHI Labortechnik AG. All rights reserved.
Copyright © BÜCHI Labortechnik AG 1998, 1999, 2000

en, Version H (32 pages)

Order No.

V-500 Operating Instructions

96696

1 Scope of Delivery

1.1 Büchi Vac V-500



Fig 1: Vac V-500

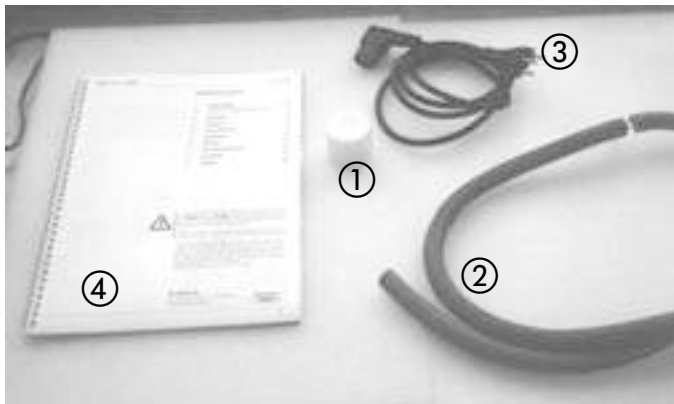

Fig 2: Enclosed parts Büchi Vac V-500

Description			Order No.
Büchi Vac V-500	230 V	50 Hz	37340
Büchi Vac V-500	120 V	50/60 Hz	37339
Büchi Vac V-500	100 V	50/60 Hz	38050

Enclosed parts

①	1	Sound absorber	37947
②	2 m	Vacuum hose	17622
③	1	Power cable PNE, 1.5m	
		Type CH	10010
		Type Schuko	10016
		Type GB	17835
		Type USA	10020
		Type AUS	17836
④	1	Operating instructions:	
		German	96695
		English	96696
		French	96697
		Italian	96698
		Spanish	96699
	1	Hose connection GL-14 straight	
	1	Hose connection GL-14 bent	

Table 1: Enclosed parts Büchi Vac V-500

Optional accessories

1	Stand with holder for valve unit, secondary condenser	38021
1	Secondary condenser complete with collecting tank	38022
1	Vacuum Controller V-800 230 V	40736
1	Vacuum Controller V-800 120 V	40737
1	Spare parts set consisting of 2 diaphragms, 2 valve heads complete	38120
1	Connecting cable Vacuum controller to the pump	38010

Table 2: Optinal accessories for Büchi Vac V-500

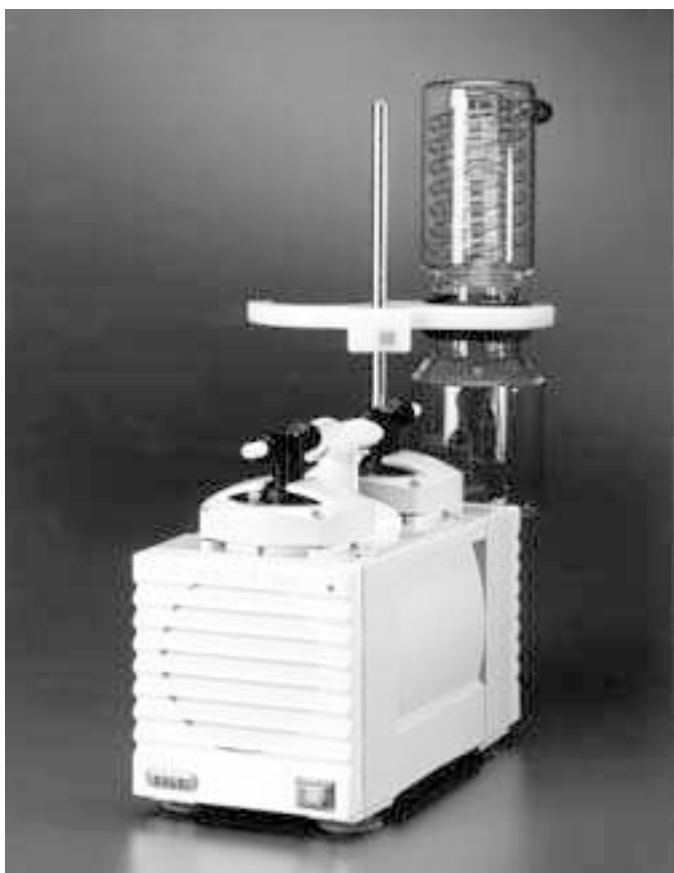

Fig 3: Vac V-501 with secondary condenser

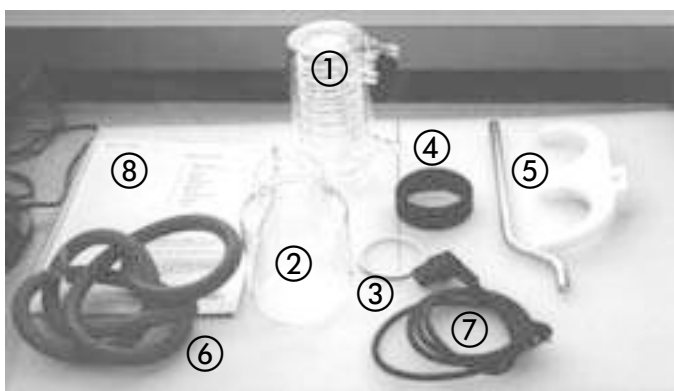

Fig 4: Enclosed parts Büchi Vac V-501 with secondary condenser

1.2 Büchi Vac V-501 with secondary condenser

Description	Order No.
Büchi Vac V-501 with secondary condenser 230 V 50 Hz	38001
Büchi Vac V-501 with secondary condenser 120 V 50/60 Hz	38006
Büchi Vac V-501 with secondary condenser 100 V 50/60 Hz	38051

Enclosed parts

①	1	Secondary condenser	37775
②	1	Collecting tank for secondary condenser	37949
③	1	Gasket for secondary condenser	37873
④	1	Holder for secondary condenser and collecting tank	38086
⑤	1	Stand with holder for secondary condenser	38021
⑥	2 m	Vacuum hose	17622
⑦	1	Power cable PNE, 1.5 m (see 1.1 for article number)	
⑧	1	Operating instructions (see 1.1 for article number)	
	1	Hose connection GL-14 straight	
	1	Hose connection GL-14 bent	
	1	Spring lock washer	37872
	1	Silicone hose	04133

Table 3: Enclosed parts Büchi Vac V-501 with secondary condenser

Optional accessories

1	Vacuum Controller V-800 230 V	40736
1	Vacuum Controller V-800 120 V	40737
1	Valve unit compl.	37968
1	Cooling water valve	31356
1	Control cable for R-134/R-144 to V-500	31466
1	Special cable for KNF controller	38015
1	Special cable for Vacuubrand	38014
1	Thermostatic jacket for secondary condenser	37616
1	Spare parts set consisting of 2 diaphragms, 2 valve heads complete	38120
1	Connecting cable Vacuum controller to the pump	38010

Table 4: Optional Accessories Büchi Vac V-501 with add. condenser



Fig 5: Vac V-502 with Vacuum Controller

1.3 Büchi Vac V-502 with Vacuum Controller V-800

Description	Order No.
Büchi Vac V-502 with Vacuum Controller V-800 230 V 50 Hz	38650
Büchi Vac V-502 with Vacuum Controller V-800 120 V 50/60 Hz	38652
Büchi Vac V-502 with Vacuum Controller V-800 100 V 50/60 Hz	38653

Enclosed parts

1	Sound absorber	37947
1	Vacuum Controller V-800 230 V	40736
	Vacuum Controller V-800 120 V	40737
1	Stand with holder for valve unit, secondary condenser	38021
1	Valve unit, complete	37968
1	Connecting cable Vacuum controller to the pump	38010
2 m	Vacuum hose	17622
1	Power cable PNE 1.5m (see 1.1 for article number)	
1	Operating instructions: (see 1.1 for article number)	
1	Hose connection GL-14 straight	
1	Hose connection GL-14 bent	

Table 5: Enclosed parts Vac V-502 with Vacuum Controller

Optional accessories

1	Secondary condenser complete with collecting tank	38022
1	Cooling water valve	31356
1	Spare parts set consisting of 2 diaphragms, 2 valve heads complete	38120

Table 6: Optional Accessories Vac V-502 mit Vacuum Controller



Fig 6: Vac V-503 with Vacuum Controller and secondary condenser

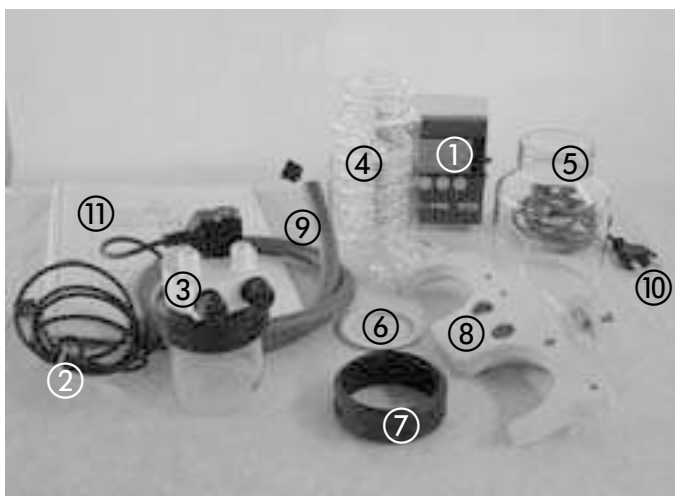

Fig 7: Enclosed parts Vac V-503 with Vacuum Controller and secondary condenser

1.4 Büchi Vac V-503 with secondary condenser and Vacuum Controller V-800

Description	Order No.
Büchi Vac V-503 with Vacuum Controller V-800 230 V 50 Hz	38654
Büchi Vac V-503 with Vacuum Controller V-800 120 V 50/60 Hz	38656
Büchi Vac V-503 with Vacuum Controller V-800 100 V 50/60 Hz	38657

Enclosed parts

① 1 Vacuum Controller V-800	40736
1 Vacuum Controller V-800	40737
② 1 Connecting cable Vacuum controller to the pump	38010
③ 1 Valve unit, complete	37968
④ 1 Secondary condenser	37775
⑤ 1 Collecting tank for Secondary condenser	38949
⑥ 1 Gasket for secondary condenser	37873
⑦ 1 Holder for secondary condenser and collecting tank	38086
⑧ 1 Stand with holder for valve unit, secondary condenser	38021
⑨ 2 mVacuum hose	17622
⑩ 1 Power cable PNE 1.5m (see 1.1 for article number)	
⑪ 1 Operating instructions (see 1.1 for article number)	
1 Hose connection GL-14 straight	
1 Hose connection GL-14 bent	
1 Spring lock washer	37872
3m Silicone hose	04133

Table 7: Enclosed parts Büchi Vac V-503 with vacuum controller and secondary condenser

Optional accessories

1 Thermostatic jacket for secondary condenser	37616
1 Cooling water valve 24V AC	31356
1 m Vacuum hose	17622

Table 8: Optional Accessories Büchi Vac V-503 with vacuum controller and secondary condenser

2 Safety

The device is built with state-of-the-art technology and according to recognized safety regulations. Nevertheless, using this device can lead to certain risks and dangers:

- If the device is not used according to these instructions.
- If the device is used by personnel who have not been properly trained..

2.1 Symbols

**Stop**

Information about risks which can lead to extensive property damage or to serious or life-threatening personal injury.

**Warning**

Information about risks which can lead to damage to one's health or to property damage.

**Reference**

Information which refers to technical requirements. Failure to heed these requirements can lead to malfunctions, poor economic performance, and production losses.

**Warning**

Surface temperature more than 60°C.

2.2 Requirements for the Operator

The device may be used only by laboratory personnel or other persons who, due to their training or professional experience, are capable of recognizing possible dangers which might arise from the use of the device.

Personnel who do not have this training or who are presently in training must be given careful and exact instruction. These operating instructions are intended for use as a basis for such instruction.

2.3 Proper Use

The device was designed and built for laboratory use. Its proper use is the evacuation of laboratory vacuum devices up to 10 mbar. This is done by means of a PTFE diaphragm pump, with or without regulation through one or more vacuum controllers.

Uses:

- Evacuation of distillation apparatus, in particular rotation evaporators.
- Vacuum filtrations
- Vacuum drying cabinets
- Drying ovens

2.4 Safety Features

Two fuses (3.15 AT) have been built into the device to protect it from a short circuit. The pump motor is protected from overheating by a temperature governor. The pump is 100% free of oil. The bearings do not require lubrication. All bearings are completely sealed and self-lubricating.

2.5 Improper Use

Any use of the device other than those given above or any use of the device which is not in accordance with the technical data shall be regarded as a misuse. The operator bears the sole responsibility for any and all damage which may result from such misuse. The device is not suitable for pumping liquids or solid particles. The result of such a use would be the destruction of the pump or a loss in performance capability.



In particular, the device must not be used in the following ways:

- Use of the device in rooms which require ex-protected apparatus.
- Processing of samples which can explode or ignite due to a blow, friction, heat, or sparks (e.g., explosives, etc.).
- Use of the device for digestions (e.g., Kjeldahl)
- Use of the pump to produce over-pressure
- Operation of the device in a surrounding temperature of $> 40^{\circ}\text{C}$.

2.6 General Risks

In general, risks can arise from

- Glass parts which are not suitable for use under vacuum conditions
- Solvents which can react with one another if they mix in the pump or in the secondary condenser.
- Ignition sources in the immediate vicinity of the pump/pump system outlet.
- Flammable gases or solvent vapors in the immediate vicinity of the device.
- Damaged glass equipment
- Bent hoses on the outlet side

2.7 Safety Measures

Protective clothing such as **goggles** and **laboratory coats** must be worn during operation of the device.

These operating instructions must be available at all times to operating personnel at the place of operation of the device and should be regarded as an integral part of the Büchi Vac V-500-503. Instructions in other languages, which may be ordered separately, must also be kept with the device.



Modifications

Modifications of the device or of spare parts or of accessories as well as the use of spare parts or accessories other than those mentioned in these operating instructions is allowed only with the prior written permission of BÜCHI Labortechnik AG.

Responsibility for the operator

The operator is responsible for the instruction of his personnel. Copies of these operating instructions in various languages can be ordered for this purpose.

The operator shall inform the manufacturer without delay of any safety-related events which might occur during operation of the device.

Regional and local statutes and regulations must be observed.



It is forbidden for anyone other than authorized maintenance personnel to remove the front or back plate using standard tools. Damaged glass equipment may not be used under vacuum conditions.

Touching any parts of the device carrying electrical current can result in fatal injury!

3 Function

The Büchi Vac V-500 is a vacuum pump suitable for evacuating laboratory equipment to a vacuum of <10 mbar. This is done with a PTFE diaphragm pump. The pump can be used as an individual device to create a vacuum and can be expanded to a complete vacuum system by means of the optional accessories such as secondary condenser and vacuum controllers (V-501/502/503).

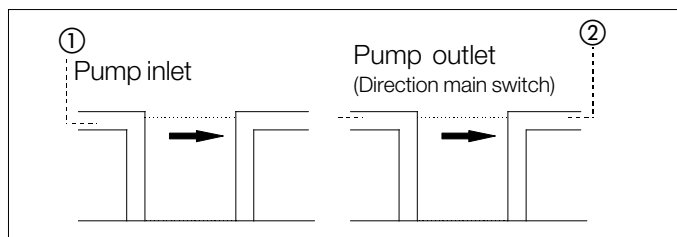

Fig. 8: Gas flow: valve heads

In the following pages, reference will often be made to pump inlet and pump outlet.

This distinction is important and can be recognized on the valve heads as follows. Arrows on both valve heads show the direction of the gas flow.

The pump inlet ①, is at the beginning of the arrow, the tip of the arrow is the pump outlet ②.



Never turn the valve heads so that the arrows point to one another!

3.1 Function of the Büchi Vac V-500

PTFE diaphragm pump: vacuum pump suitable for evacuating laboratory devices <10 mbar.



Fig. 9a: Vac V-500 front view

- ① Main switch
- ② Pump outlet GL-14
- ③ Pump inlet GL-14
- ④ Rod fastening
- ⑤ Stand rod socket, front
- ⑥ Stand rod socket, rear

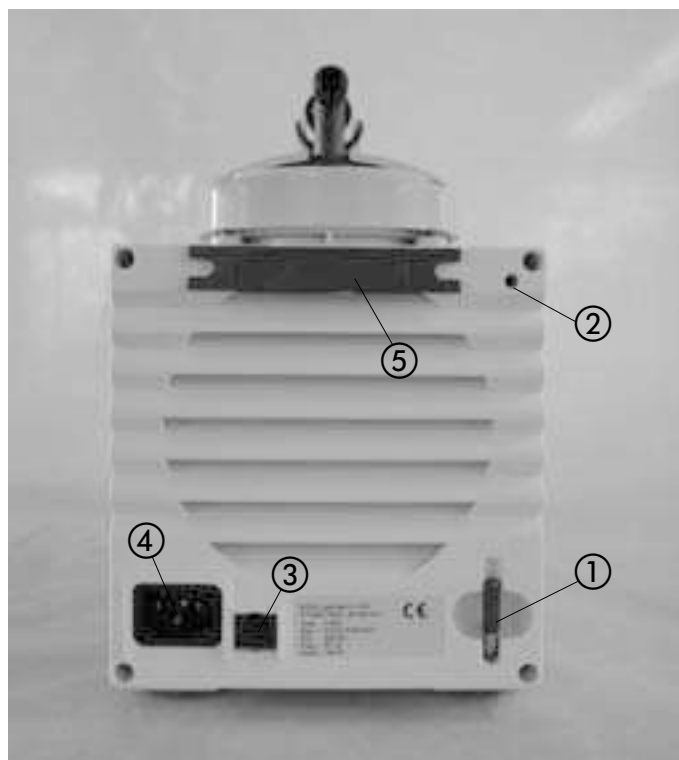

Fig. 9b: Vac V-500 rear view

- ① Allen wrench
- ② Rod fastening
- ③ Connection 24 V ~ = Switchbox
- ④ Power connection
- ⑤ Installation tool

In case a control cable is connected to the 24V connection the switchbox switches automatically to external. The main switch has to be ON (EIN) and can only be switched ON or OFF via the controller.

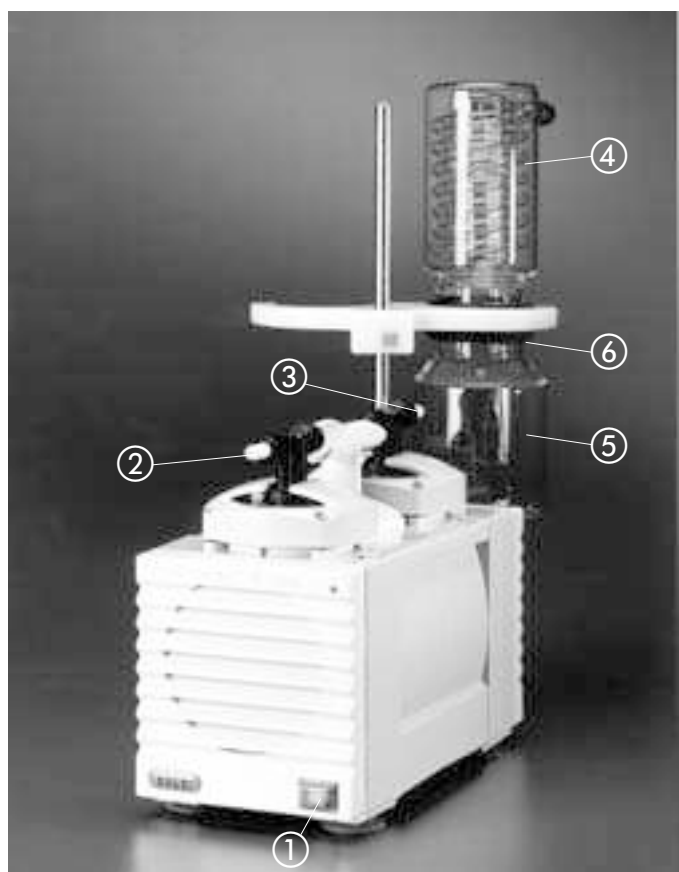

Fig. 10: Vac V 501 with secondary condenser

3.2 Function of the Büchi Vac V-501

Vacuum system with PTFE diaphragm pump V-500 and secondary condenser, suitable for evacuating laboratory equipment to a vacuum of <math><10\text{ mbar}</math>. The secondary condenser removes any solvent vapors following the pump (to the physical minimum).

- ① Main switch
- ② Pump outlet
- ③ Pump inlet
- ④ Secondary condenser
- ⑤ Collecting tank
- ⑥ Supporting ring

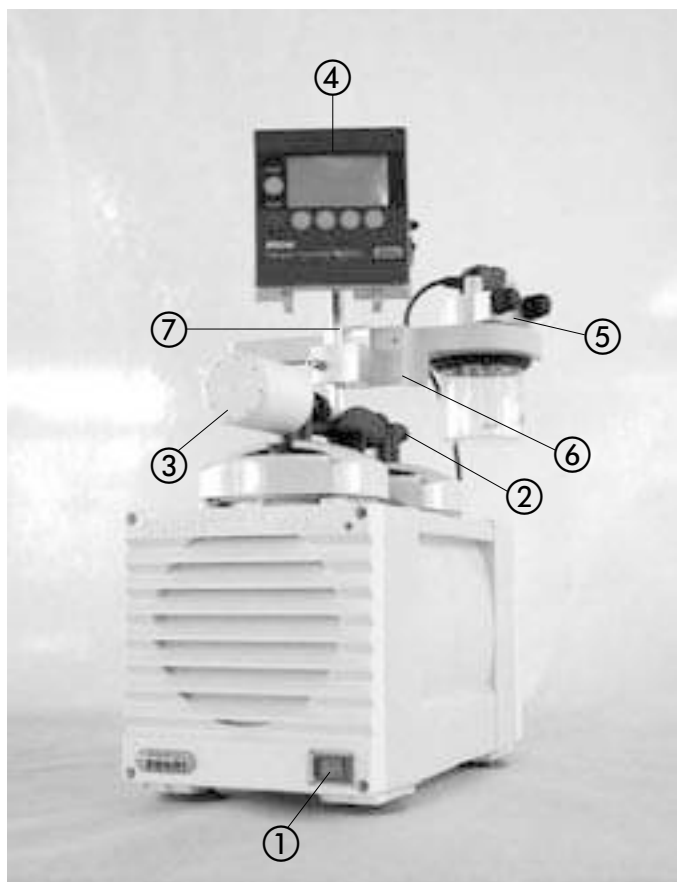

Fig. 11: Vac V-502 with vacuum controller V-800

3.3 Function of the Büchi Vac V-502

Vacuum system with PTFE diaphragm pump V-500 and vacuum controller, suitable for controlled evacuation of laboratory devices to a vacuum of <math><10\text{ mbar}</math>. This system creates, regulates, and maintains a vacuum at a constant level by automatically resuming operation in the event of a vacuum loss and restoring the vacuum to the set level. To achieve this, the vacuum pump is turned on and off directly.

The vacuum, selected for the specific solvent, permits almost 100% condensation in the condenser of the distilling device. This permits a massive reduction of solvent emissions. In addition, the flow of the cooling water can be controlled during the distillation process by an optional cooling water valve. 95% of the cooling water can be saved in this way. The vacuum controller turns the pump on and off as required by means of the integrated switchbox.

- ① Main switch
- ② Pump inlet
- ③ Sound absorber
- ④ Vacuum Controller V-800
- ⑤ Valve unit
- ⑥ Holder
- ⑦ Stand



The sound absorber does not prevent emissions into the laboratory air. For this reason, the pump must be placed under a fume hood when the sound absorber is used.

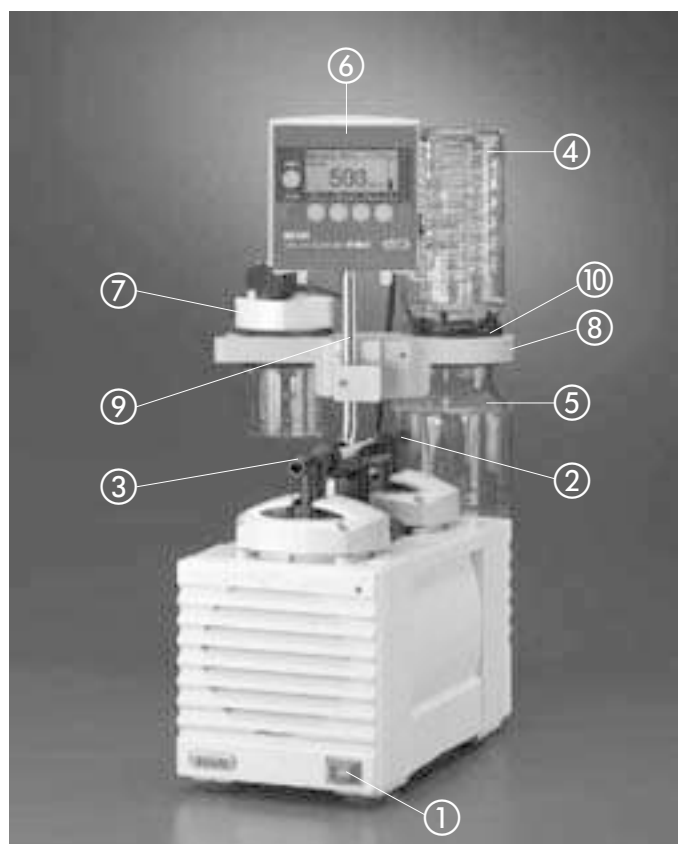

Fig. 12: Vac V-503

3.4 Function of the Büchi Vac V-503

Vacuum system with PTFE diaphragm pump V-500 and vacuum controller, suitable for controlled evacuation of laboratory devices to a vacuum of <math><10\text{ mbar}</math>. This system creates, regulates, and maintains a vacuum at a constant level by automatically resuming operation in the event of a vacuum loss and restoring the vacuum to the set level. To achieve this, the vacuum pump is turned on and off directly.

The vacuum, selected for the specific solvent, permits almost 100% condensation in the condenser of the distilling device. This permits a massive reduction of solvent emissions. The vacuum controller turns the pump on and off as required by means of the integrated switchbox. The secondary condenser removes any solvent vapors following the pump. In addition, the flow of the cooling water can be controlled during the distillation process by an optional cooling water valve. 95% of the cooling water can be saved in this way.

- ① Main switch
- ② Pump inlet GL-14
- ③ Pump outlet GL-14 – connect to secondary condenser using vacuum hose (see 3.5)
- ④ Secondary condenser
- ⑤ Collecting tank
- ⑥ Vacuum Controller V-800
- ⑦ Valve unit
- ⑧ Holder
- ⑨ Stand
- ⑩ Elastic ring

3.5 Function of the secondary condenser

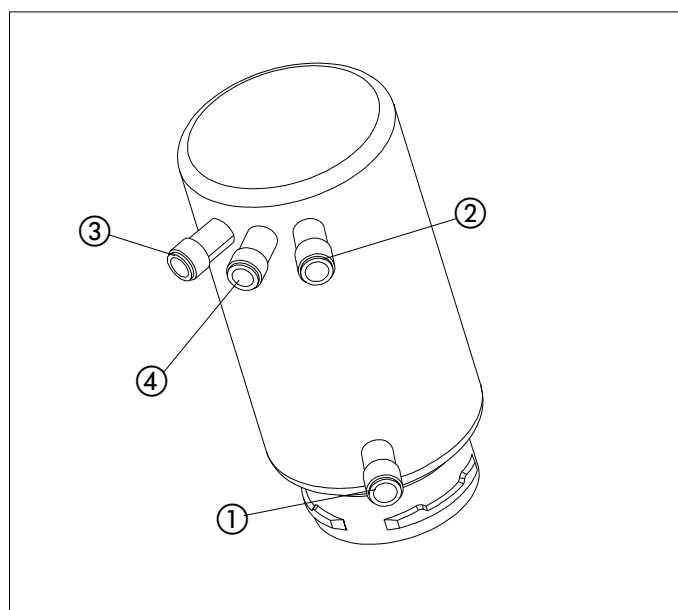

Fig. 13: Secondary condenser

- ① Cooling water inlet
- ② Cooling water outlet
- ③ Intake for exhaust gases from the pump
- ④ Outlet for exhaust gases

Assembly:

- Mount gasket in holding ring
- Click holding ring into white holder
- Place the supporting ring on the holding ring and secure the secondary condenser by pressing down lightly and turning 60°.
- Mount collecting tank

3.6 Function of the Vacuum Controllers

See separate operating instructions.

3.7 Function of the valve unit

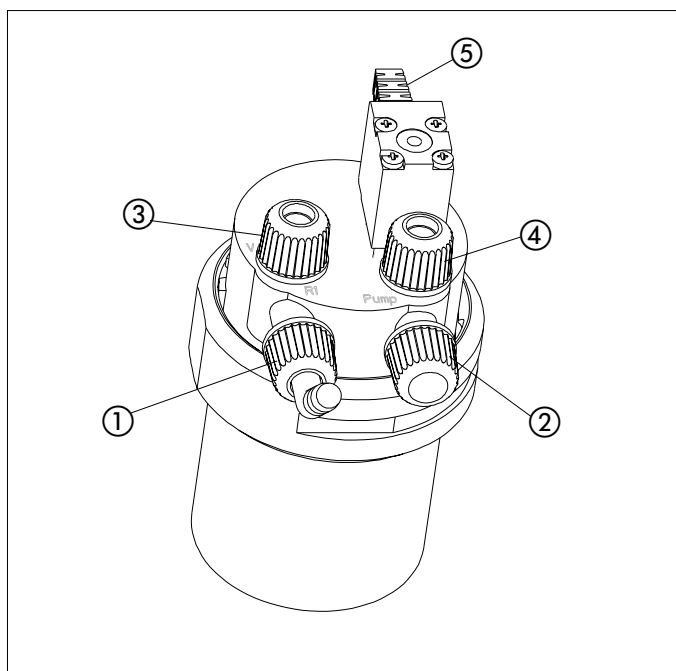

Fig. 14: Valve unit

- ① Hose connection to 1st rotation evaporator
- ② Hose connection to 2nd valve unit
- ③ Hose connection to vacuum controller
- ④ Hose connection to pump inlet (intake end)
- ⑤ Connecting cable to vacuum controller

When the unit is operated with only one rotation evaporator, the outlet R2 ② is closed with a cap.



During operation, the valve unit is in a vacuum. Please examine glass parts for splinters, cracks, stars.

4 Putting into operation



Please check all parts for damage when unpacking. It is important that any transport damage be discovered when the parts are unpacked. If necessary, a record of the condition of the parts should be made immediately (report to postal service, railway service, or shipping company).

Keep the original packaging for the event of a later transport.

4.1 Placement

The device must be set up on a stable, clean, and level surface. The surrounding temperature may not exceed 40° C. Proper air circulation is necessary.



The device must be placed at a minimum of 20 cm from walls and other objects in order to prevent damage. Containers, chemicals, or other devices may not be placed behind the pump.

4.2 Connections

4.2.1 Electrical connections



Ensure that the electric current available from the location's outlets is the same voltage as that indicated by the label on the apparatus. The device must always be connected to a grounded outlet. External couplings and extension cords must have a protective conductor (3-pin couplings, cables, or plug and socket connections). There must be no break in any part of the protective conductor. This will avoid risks resulting from internal defects.

Connect the pump to the power source with the enclosed cable.

4.2.2 Other connections

Before putting the device into operation, the screw caps on the connections must be replaced by GL-14 connections or sound absorbers.

Please be sure that none of the hoses are bent closed (bends, the device is resting on the hose).

Replace brittle hoses.

The hoses should be secured with standard hose clamps or cable binders for safety.

The device must never be put into operation without an exhaust hose. The exhaust hose must not be pointed towards hot objects or towards objects which produce sparks.

The exhaust hose must end in a fume hood so that none of the vapors from the solvents can be released in the room.

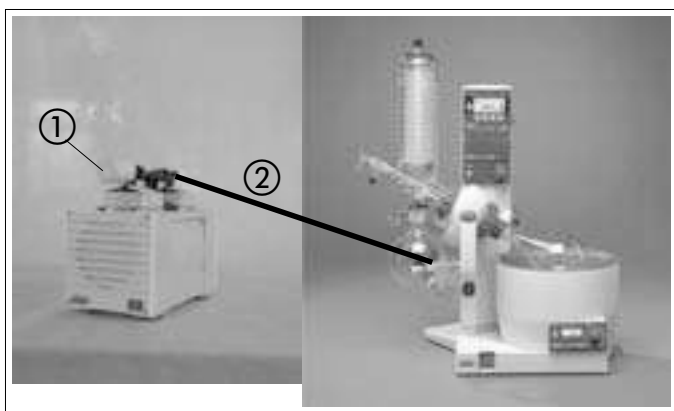

Fig. 15: V-500 connection to Rotavapor

4.3 Büchi Vac V-500

- ① Sound absorber
- ② Vacuum connection to valve unit

- Screw the sound absorber onto the pump outlet.
- Connect the pump inlet to the rotation evaporator valve unit using the vacuum hose, as shown in the drawing.
- Connect the power cable.

4.4 Büchi Vac V-501 with secondary condenser

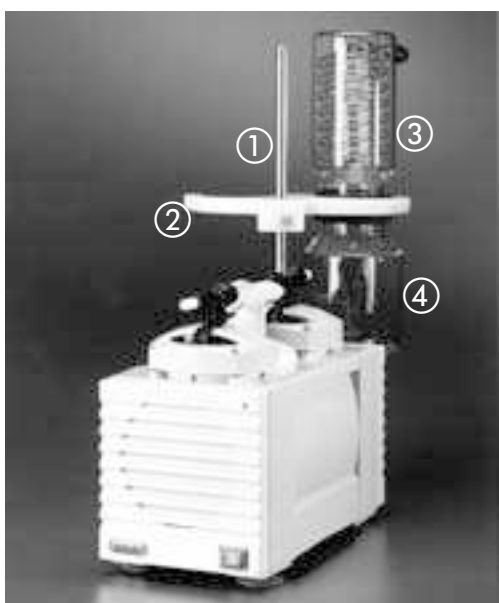

Fig. 16: V-501 with secondary condenser

- ① Stand
- ② Holder
- ③ Secondary condenser
- ④ Collecting tank

Mechanical and electrical connections

- Insert the stand ① into the desired socket of the pump and secure it with an allen wrench.
- Secure the white plastic holder ② to the stand ① using an allen wrench.
- Connect the power cable.

Vacuum connections

- ① Connect the pump inlet to the valve unit as shown in the drawing.
- ② Connect the secondary condenser to the pump outlet.

Secondary condenser

- Secure the secondary condenser ③ and the collecting tank ④ to the holder. Make sure that the gasket has been placed between the two glass parts.
- Connect the secondary condenser ③ to the condenser of the Rotavapor with hoses. The cooling water should flow first through the secondary condenser, then through the Rotavapor's condenser.
- Connect an exhaust hose to the outlet of the secondary condenser ③. This hose should run into a fume hood.

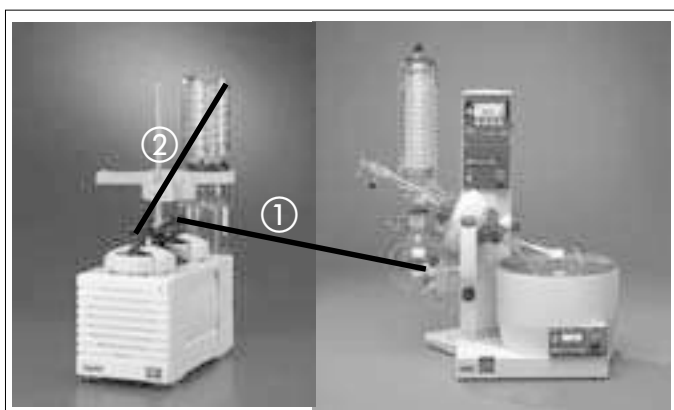

Fig. 17: V-501 with secondary condenser connection to Rotavapor

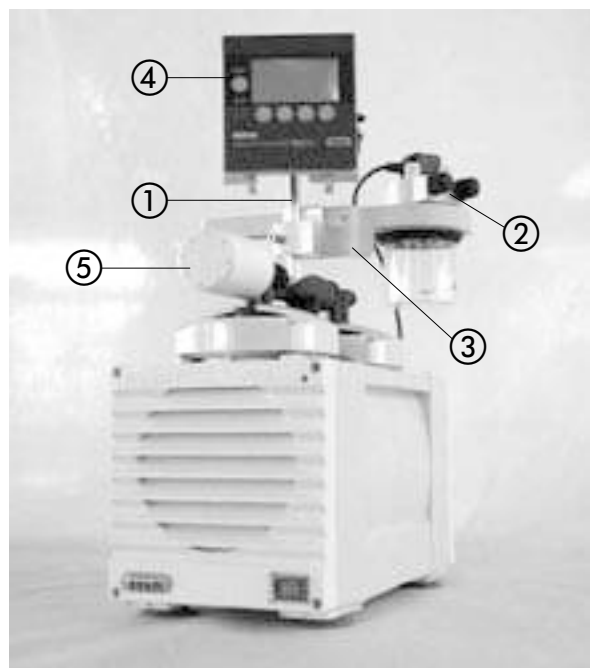

Fig. 18: VAC-502

4.5 Büchi Vac V-502

- ① Stand
- ② Valve unit
- ③ Holder
- ④ Vacuum Controller V-800
- ⑤ Sound absorber

Mechanical and electrical connections

- Screw sound absorber ⑤ onto pump outlet
- Insert the stand ① into the desired socket on the pump and secure it.
- Secure the white plastic holder ③ to the stand ①.
- Fasten the vacuum controller V-800 ④ to the stand ①.
- Insert the valve unit ② into the holder ③.
- Attach the cable from the valve unit ② to the vacuum controller connection „V“ (Connection A).
- Join the connection Pump of the vacuum controller to the 24 V ~ on the V-500 with the control cable (Connection B).
- Connect the power cable.

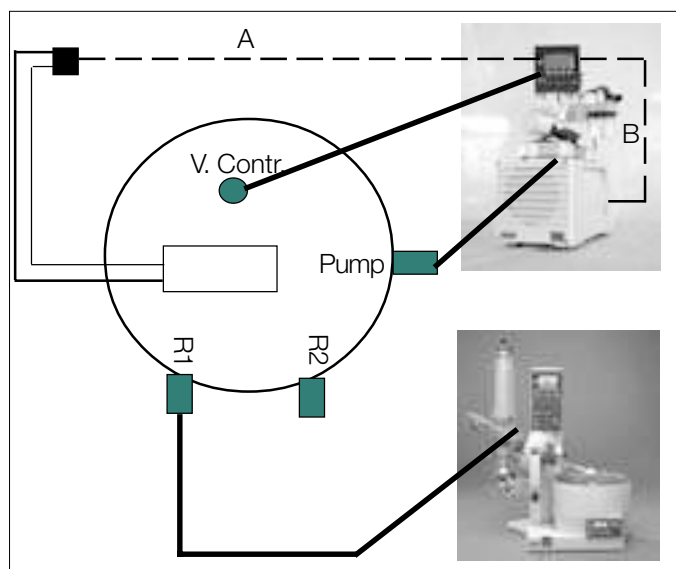

Fig. 19: Installation Vac V-502 with V-800 with Rotavapor

Vacuum connections

The following vacuum connections are made using the vacuum hose:

- ① Pump inlet to the valve unit (via the connection “Pump”).
- ② Rotation evaporator to the valve unit (via the connection “R1”).
- ③ Vacuum controller V-800 to the valve unit (via the connection “V.Contr.”).
- Fit sealing cap on connection R2.

The pump will now be turned on and off by the V-800.

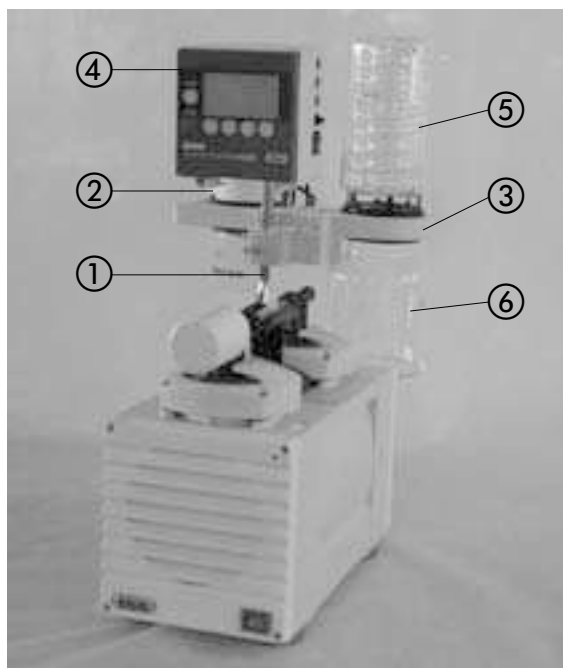

Fig. 20: Büchi Vac V-503

4.6 Büchi Vac V-503

- ① Stand
- ② Valve unit
- ③ Holder
- ④ Vacuum Controller V-800
- ⑤ Secondary condenser
- ⑥ Collecting tank

Mechanical and electrical connections

- Insert the stand ① into the desired socket on the pump and secure it.
- Secure the white plastic holder ③ to the stand ①.
- Fasten the vacuum controller V-800 ④ to the stand ①.
- Insert the valve unit ② into the holder ③.
- Attach the cable from the valve unit ② to the vacuum controller connection „V“ (Connection A).
- Join the connection Pump of the vacuum controller to the 24 V ~ on the V-500 with the control cable (Connection B).
- Connect the power cable.

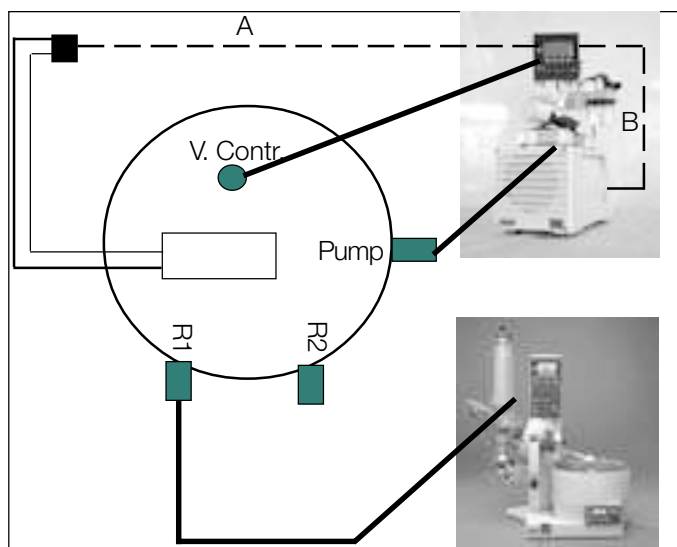

Fig. 21: Installation Vac V-503 with V-800 with Rotavapor

Vacuum connections

The following vacuum connections are made using the vacuum hose:

- Pump inlet to the valve unit ② (via the connection “pump”).
- Rotation evaporator to the valve unit ② (via the connection “R1”).
- Vacuum controller V-800 to the valve unit ② (via the connection “V.Contr.”).
- Fit sealing cap on connection R2.

Secondary condenser

- Secure the secondary condenser and the collecting tank to the holder ③ as shown in the diagram. Make sure that the gasket has been placed between the two glass parts.
- Connect the secondary condenser ⑤ to the condenser of the Rotavapor with hoses. The cooling water should flow first through the secondary condenser, then through the Rotavapor’s condenser.
- Connect the pump outlet to the secondary condenser, see 3.5.
- Connect an exhaust hose to the outlet of the secondary condenser. This hose should run into a fume hood.



See Section 3.5 for the connections for the secondary condenser.

4.7 Büchi Vac V-500 with multiple Vacuum Controllers V-800

The vacuum pump and the vacuum system can both be fitted with 2 or more vacuum controllers at any time.

Hose connections:

R1	to the vacuum connection of the respective rotation evaporator
Contr.	to the respective vacuum controller V-800
Pump	first valve unit to the V-500 pump inlet (intake end) second "pump" valve unit to R2 on first valve unit (see A) fit sealing cap on R2 of the second valve unit
A	connection between first valve unit and second valve unit
B	to rotation evaporator 1
C	to rotation evaporator 2

Electrical connections:

Valve units	connect to Plug „V“ of the respective vacuum controller
Control cable 1. V-800	join to connection Pump of the first V-800 and to connection 24 V ~ = on the rear side of the V-500
Control cable 2. V-800	join to connection Pump of the second V-800 and to the double plug of the control cable of the first V-800.

Using the same method, additional users can be connected to each other via valve units.

- ① R1
- ② R2
- ③ Pump
- ④ Controller

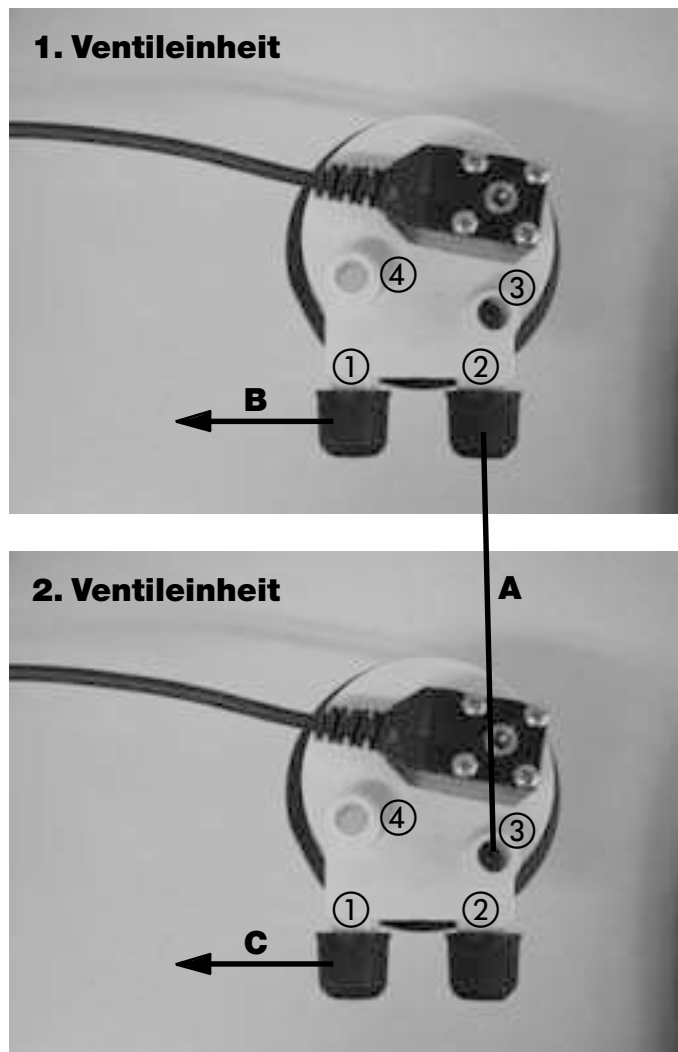

Fig. 22: Connection of multiple vacuum controllers V-800

5 Operation

Please be sure that the device has been properly installed according to the instructions in Chapter 4, Installation.

5.1 Description of the operation features on the Büchi Vac V-501 with secondary condenser

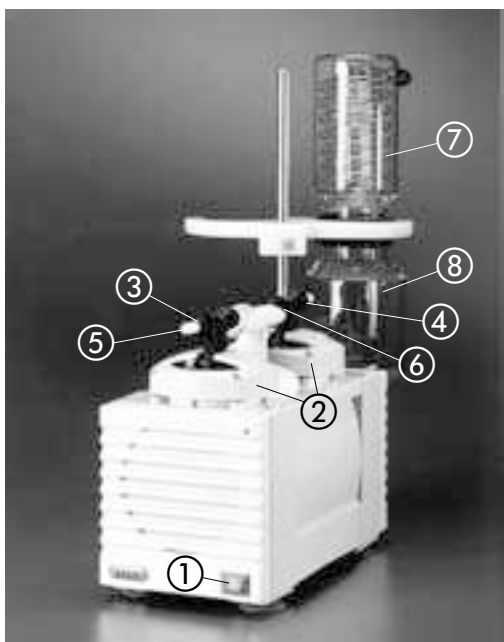

Fig. 23: Vac V-501 with secondary condenser

- ① Main switch
- ② Glass pump heads
- ③ Inlet valves
- ④ Outlet valves
- ⑤ Pump outlet
- ⑥ Pump inlet (intake end)
- ⑦ Additional condenser
- ⑧ Collecting tank

5.1.1 Working with the Büchi Vac V-500 with secondary condenser

Start the pump by using the main switch ①. If pressure conditions are too low, the secondary condenser condenses out the solvent vapors and collects them in the collecting tank. By twisting this tank clockwise, it can be removed, emptied, and then returned to operating position.

5.1.2 Adding a vacuum controller to the Büchi Vac V-500

If you wish to ensure that both the pump and the vacuum connection to the user are interrupted when the desired vacuum has been reached, we recommend that you supplement the vacuum system with a vacuum controller.

There are several possibilities how the Vacuum System can be used with a Vacuum Controller.

The most important are:

- 1 Rotavapor with 1 V-800
- 1 Rotavapor with 1 B-168
- 2 Rotavapor with 2 V-800
- 2 Rotavapor with 2 B-168
- 1 Rotavapor with integrated Controller
- 2 Rotavapor with 1 V-800 and 1 B-168
- 1 Rotavapor Vacuum Controller not from Büchi

Connection of vacuum pump to the V-800 controller, valve unit and rotation evaporator

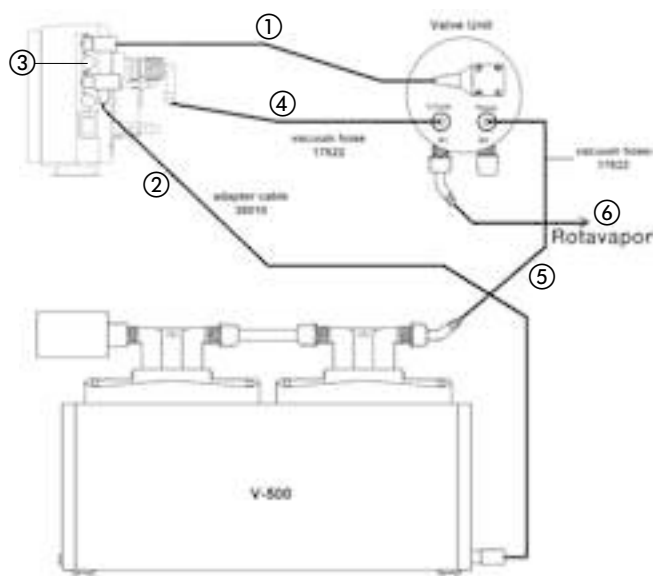

Connection of vacuum pump to the B-168 controller, valve unit and rotation evaporator

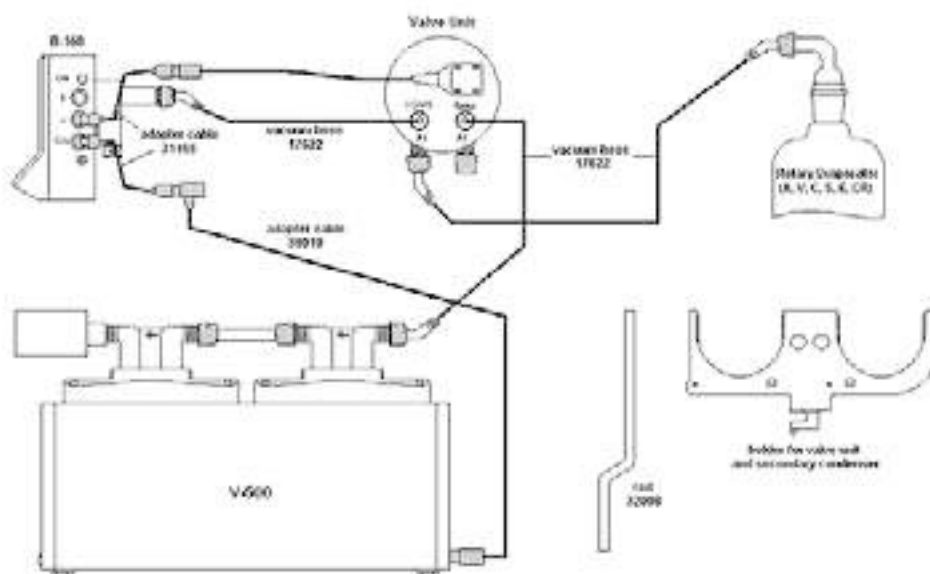

V-500 Connections with two V-800/V-805, two valve units and two R-200/R-205

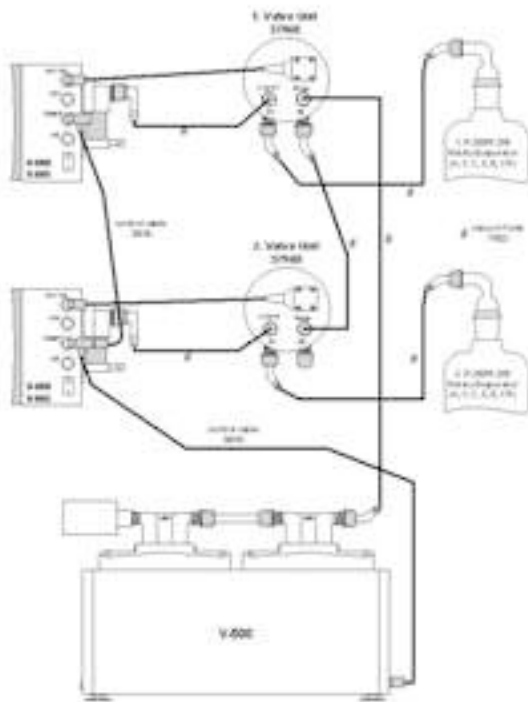

V-500 Connections with two B-168, two valve unit and two Rotary Evaporator (R-114, R-124, R-3000 or older units)

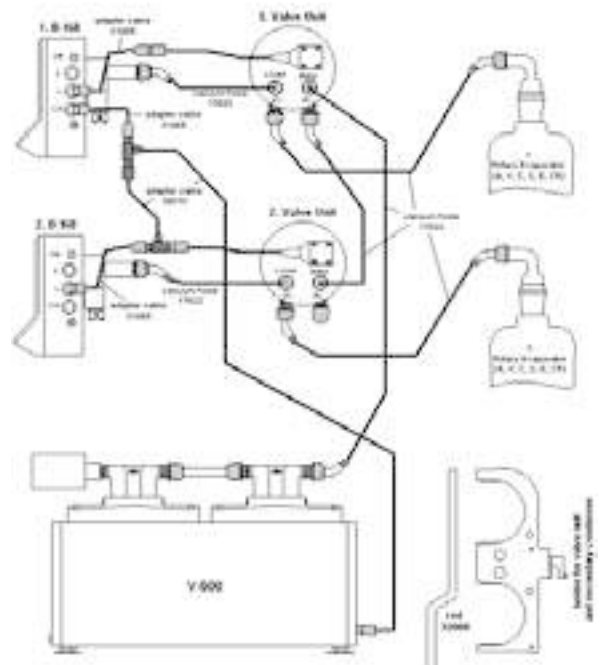

Connections of V-500, R-134 or R-144 and valve unit

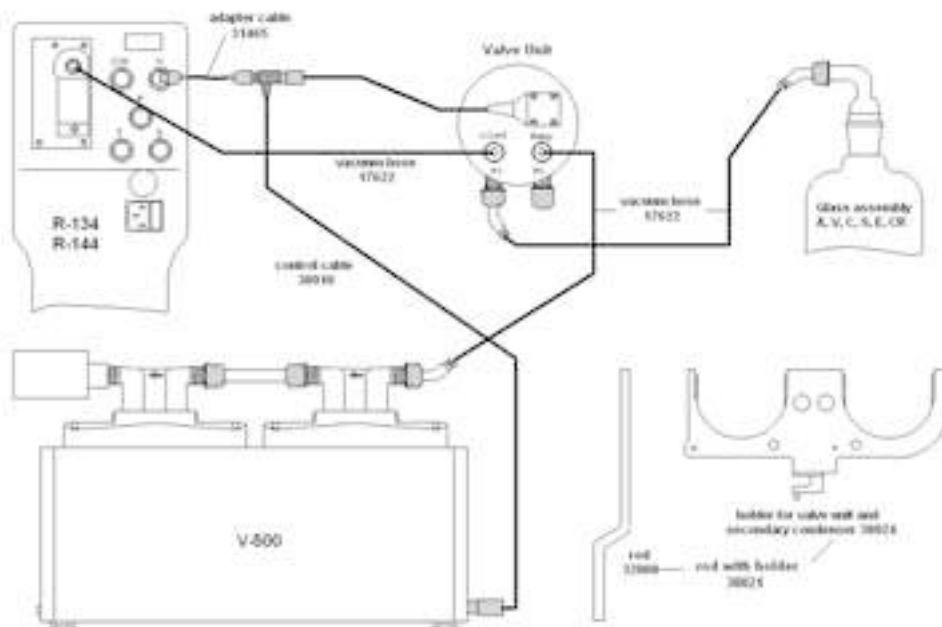

5.2 Description of the integrated switchbox

The integrated switchbox allows particularly quiet and environmentally-friendly operation. When the desired vacuum has been reached, the pump is turned off and does not run again unless the hysteresis set on the V-800 is exceeded.

6 Maintenance

6.1 Cleaning

Valve head

If the end vacuum of the pump can not be reached the problem is often caused by stuck valve plates. To clean them do the following steps:

- 1) remove all of the connections to the pump and the sound absorber
- 2) switch the pump on
- 3) inject a small amount of about max. 10 ml at one time of acetone at the inlet side of the pump and wait till the pump makes the same sound as before injecting the solvent. The injection should only be done with safety washing bottles as seen on the picture.
- 4) Repeat point 3) four to five times
- 5) Leave the pump running for about 2 minutes and check then if the end vacuum can be reached.
- 6) If the end vacuum can not be reached after this cleaning procedure, repeat it again before going on with Chapter 6.2.



Fig. 24: Cleaning Valve head



Housing

Before cleaning, please disconnect the apparatus from the power source.

The housing is made of plastic. Drops of acid must be wiped away immediately with a damp cloth. Using organic solutions for cleaning (exception: ethanol) can cause damage and is not allowed.

Glass parts can be rinsed out with standard cleaning agents (e.g., mild soap solutions). After they have been cleaned and dried thoroughly, they must be examined visually for splintered places or cracks. As the valve unit is in a vacuum during operation, this examination must be carried out conscientiously.

Hoses and gaskets must also be examined visually; if cracks have developed or if they have become brittle, they must be replaced with suitable new hoses.



Büchi offers sets of spare parts which make it easier for the user to obtain spare parts.

The necessary articles can be found in Chapter 8.1, Spare Parts.

6.2 Removal and Assembly of the Pump Heads, Valve Heads and Diaphragms

Under conditions of normal usage, the diaphragms and the valve plates will rarely require replacement.

If the benchmarks of the function checkup (6.1) are not met, the pump heads, diaphragms, and valve heads should be cleaned.

If the pump's performance does not improve, the valve heads (38025) and possibly the diaphragms must be replaced (Spare Parts Set 38120).



Attention: Before replacing the diaphragms, please disconnect the apparatus from the power source.



The parts of the pump head are delicate. Pay close attention to ensure that the glass head, the valve head, and the diaphragms are not subjected to mechanical damage. Before assembly, the parts must be examined for nicks, chips, or deformation.

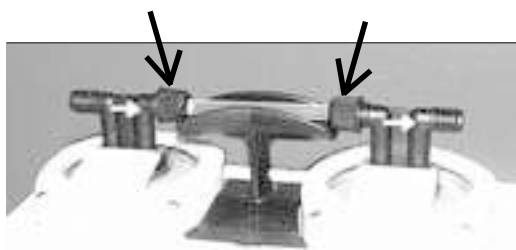

Removal and cleaning of valve head

1. Release both of the black hose couplings GL-14 between the pump heads.
2. Using the allen wrench provided, loosen crosswise with a quarter-turn each and remove the 4 screws on the valve head top.
3. Carefully remove the valve head top with the valve head and glass head.
4. Place the entire part on a soft surface. The glass head can now be removed by applying light pressure to the valve head.

The valve head, glass head, and diaphragms can now be cleaned with a suitable cleansing agent (e.g., acetone), or defective parts can be replaced. The valves of the valve head can be cleaned by putting the whole valve head into an acetone bath. If they are still contaminated, use an ultrasonic bath.



Avoid hitting the sides and edges of the glass head. A glass head which has been dropped may not suffer any apparent damage, but could break if used again!



Removal of the diaphragms

Only remove the diaphragms if they are broken or can not be cleaned in a mounted way. They can be released by turning them counterclockwise.

Replacement of the diaphragms

Before you replace the diaphragm make sure, that the diaphragm holder fits tight on the lower side of the diaphragm. There must be **no gap** between holder and diaphragm

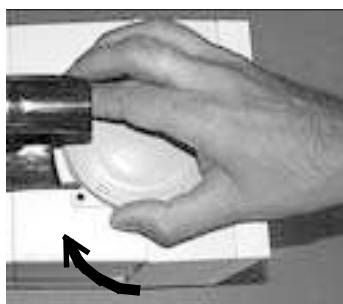

The diaphragm and the diaphragm holder can then carefully be screwed on and tightened by hand with the same force as you have needed to detach it before! Check again if there is **no gap** between diaphragm and holder after replacing the diaphragm.

Replacement of the pump head and assembling

1. Before replacing the valve head check if the valves are not stuck together by holding the head between two fingers. You should hear a soft clicking while shaking it carefully.
2. Place the valve head into the valve head top. Check if the rubber sealing is symmetrical placed in the metal part of the valve head top. Then snap the glass head into the top so that the knobs on the glass head fit into the spaces on the valve head. Place the assembled pump head on the diaphragms.



Pay careful attention to the arrows on the upper part of the valve heads. They **must** point in the **same direction** on both pump heads.

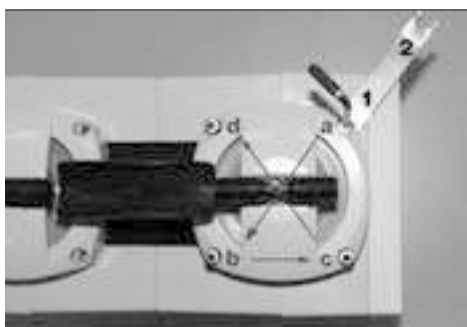

3. Place the setting gauge side number 1 between the metal top and thread and screw the first screw (a) in so that the setting gauge can be removed without force. After the first screw do the same procedure with the screw (b) and then with the screw (c) and last but not least again with the screw (d) (Crosswise).



4. If all screws are on the level 1 change to the side 2 of the setting gauge. Place this side between metal top and thread and screw the first screw (a) one quarter-turn in. After this change the setting gauge to screw (b) and screw this one also a quarter-turn in. Go on with the screw (c) and (d) in the same way and repeat this procedure till you can't remove the setting gauge without force. Loosen the screw a little bit to take out the setting gauge and leave the screw on this position.



Hold the short red part of the allen wrench to tighten the screws, which will provide for the correct tightness. You should only use screws with a blue spot on the thread. The blue spot is a Tufloc coating which prevents the screw from loosening during operation or transportation of the pump. If you are using a new screw it could be possible that you need a slightly higher force to screw this in. This doesn't matter and doesn't influence the result of your work.



5. Now connect the connecting hose, tighten the hose connections, and then assemble the second pump head the same way as the first one.

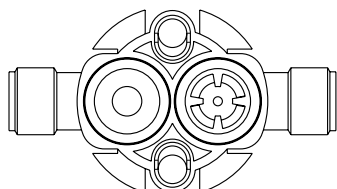

Valve head without valves

6. If the vacuum is not achieved, it may be necessary to replace or clean the valve head seals. To do this, remove the valve heads as indicated in 6.2. 1-4.

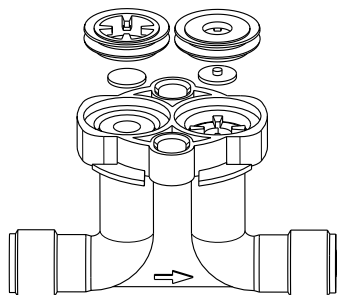

Insert the valves

Carefully take the white sealing rings out of the retainer using the valve reed and place them in an ultrasonic bath (if possible).



Valve head with inserted valves

Refit the cleaned individual parts or replacement parts as shown in the diagram.

6.3 Function control

The function control should be done each year according this instruction:

- Cleaning (see Chapter 6.1 and 6.2)
- Visual control of the device, connection cable, glass parts and tube connection.

Deviations:

Suction time of a volume of 3 lt on end vacuum of 20 mbar is longer than 60 seconds.

6.4 Customer Service

Work on or in the apparatus may be carried out only by authorized service personnel. These are people with sound technical vocational training and knowledge of the risks which result when safety measures are disregarded. BÜCHI customer service offices have service manuals specific to the various apparatus; these manuals can be obtained only by authorized personnel.

The addresses of the official BÜCHI customer service offices are listed on the last cover page of these operating instructions. If malfunctions arise or if you have technical questions or problems in operating the apparatus, please turn to these offices.

BÜCHI's customer service provides the following services:

- Spare parts service
- Repair service
- Maintenance service
- Technical consulting.

6.5 Working with strong acids / bases on Büchi VAC V-500 – 513



If strong acids or bases are removed with a Vacuum pump, protecting clothing such as goggles and laboratory coats must be worn during operation of the device.

If strong acids or bases are distilled we highly recommend to rinse the pump after the application to increase the lifetime of the instrument.

That means 5-10 ml of water should be sucked in through the pump inlet and collected directly after the pump outlet. This process should be repeated as long as the pH of the liquids coming out of the pump outlet, is between 3-9.

After that the pump is been dried, by sucking air through the pump for 2-3 min.

7 Putting out of order



Before the device can be moved, the power cable must be disconnected and all hoses taken off.

7.1 Storage/Transport

Clean the device thoroughly (see 6.1). Any chemicals remaining in the device must be removed completely and the glass parts must be washed. Return the device to the original packaging for storage and transport.

7.2 Disposal

Chapter 9, Appendix, contains a list of the materials used in manufacturing the device so that it can be disposed of in accordance with environmental regulations. This ensures that the various parts can be separated and recycled properly.

Please observe the valid regional and local statutes in disposing of the device.

8 Spare parts

Only original spare parts and accessories from BÜCHI guarantee that the device will function properly and safely. Spare parts and accessories from other manufacturers may be used only with the express permission of BÜCHI AG. General safety regulations and Chapter 6 must be observed when assembling or dismantling the device. Before putting the device into operation, please check that it is fully functional as described in Chapter 6.2. Production according to this manual is forbidden. The copyright is owned by the firm Büchi Labortechnik AG.

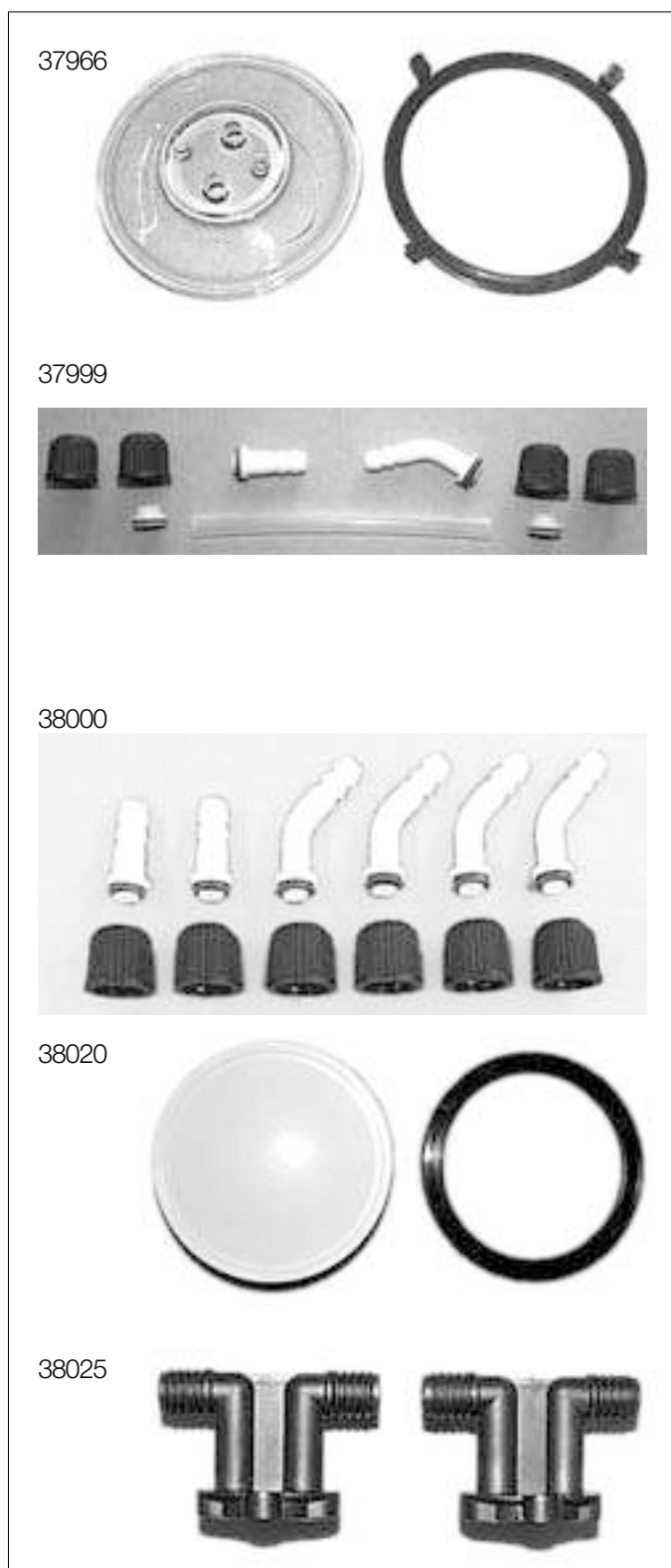

Fig. 25a: Spare parts

8.1 Spare parts

1	Spare parts set with 2 valve heads and 2 diaphragms	38120
1	Glass head set (with 1 glass head)	37966
1	Valve head set (with 2 valve heads)	38025
1	Diaphragm set (with 1 diaphragm)	38020
1	Set of hose connections (2 x bent / 2 x straight / 6 x screw caps) 2 Sealing caps 1 PTFE hose	37999
1	Set of hose connections (4 x bent / 2 x straight / 6 x screw caps)	38000
1	Control cable Vacuum Controller V-800 to V-500, or B-721 zu 721	38010
1	Secondary condenser	37775
1	Holder for secondary condenser and collecting tank	38086
1	Collecting tank for secondary condenser	37949
1	Spring lock washer	37872
1	Gasket for secondary condenser or valve unit	37873
1	Collecting beaker for valve unit	38005
1	Signal cable for KNF vacuum controller	38015
1	Signal cable for Vacuubrand vacuum controller	38014
1	Sound absorber	37947
1	Rubber vacuum hose	17622
1	PVC vacuum hose	04113
1	Cooling water hose	04133
1	Stand with holder for valve unit/ secondary condenser	38021

Table 9a: Spare parts



Fig. 25b: Spare parts

1	Valve unit complete	37968
1	Cable set for combination with Rotavapor R-134/144 or B-168	31466
1	Cooling water valve	31356
1	Thermostatic jacket for secondary condenser	37616
1	Installation tool	38614
1	Valve set	41977

Table 9b: Spare parts

9 Appendix

9.1 Technical data

	V-500	V-501 / V-502 / V-503
Measurements (L x B x H)	150 x 294 x 236 mm	230 x 420 x 400 mm
Weight	8 kg	9-11 kg
Voltage	230 V 50 Hz	230 V 50 Hz
	220 V 60 Hz	220 V 60 Hz
	120 V 50/60 Hz	120 V 50/60 Hz
	100 V 50/60 Hz	100 V 50/60 Hz
Power consumption	240 W	240 W
Surrounding temperature	5...40 °C	5...40 °C
Final vacuum possible	< 10 mbar	< 10 mbar
Pumping volume	1.6 m ³ /h	1.6 m ³ /h
Relative humidity	max. 80%	max. 80%
Excess voltage category	II	II
Degree of contamination	2	2
V-800	see Operating instructions V-800	
Connection 24V-Switchbox	DC	
	24V / 30 mA	

Table 10: Technical data

9.2 Materials used

Description	Material	Material code
Pump heads	Glas	3.3
Housing	Aluminium	
Housing cover	PBT	
Diaphragms	PTFE / rubber	
Valve plate	PEEK	
Valve head	PEEK	
Vacuum hoses	PTFE / rubber	
Gasket rings valves	ETFE	
Diaphragms, valve unit	Perfluorelastomer	
Gasket secondary condenser / valve unit	PTFE / PEEK	

Table 11: Materials

9.3 FCC requirements (for USA and Canada)

English:

This equipment has been tested and found to comply with the limits for a Class A digital device, pursuant to both Part 15 of the FCC Rules and the radio interference regulations of the Canadian Department of Communications. These limits are designed to provide reasonable protection against harmful interference when the equipment is operated in a commercial environment.

This equipment generates, uses and can radiate radio frequency energy and, if not installed and used in accordance with the instruction manual, may cause harmful interference to radio communications. Operation of this equipment in a residential area is like to cause harmful interference in which case the user will be required to correct the interference at his own expense.

Français:

Cet appareil a été testé et s'est avéré conforme aux limites prévues pour les appareils numériques de classe A et à la partie 15 des réglementations FCC à la réglementation des radio-interférences du Canadian Department of Communications. Ces limites sont destinées à fournir une protection adéquate contre les interférences néfastes lorsque l'appareil est utilisé dans un environnement commercial.

Cet appareil génère, utilise et peut radier une énergie à fréquence radioélectrique, il est en outre susceptible d'engendrer des interférences avec les communications radio, s'il n'est pas installé et utilisé conformément aux instructions du mode d'emploi. L'utilisation de cet appareil dans les zones résidentielles peut causer des interférences néfastes, auquel cas l'utilisateur sera amené à prendre les dispositions utiles pour polier aux interférences à ses propres frais.

9.4 Declaration of conformity

We **Büchi** Labortechnik AG
Postfach, CH-9230 Flawil
Switzerland

do hereby declare on our responsibility that the product:

BÜCHI VAC V-500 / V-501 / V-502 / V-503

which is the object of this certification, is in accordance with the following norms:

EN 61010-1:1993 (~ IEC 1010-1, VDE 0411-1)

Safety regulations for electrical measuring, control, regulation, and laboratory devices: general requirements

EN 55011:1991/B (~ VDE 0875/B, VDE 0871/B)

Limits and measuring procedures for interference from industrial, scientific, and medical high-frequency devices

EN 61000-3-2: 1995/1996

Limits for harmonic current emissions

EN 61000-3-3: 1995

Limitation of voltage fluctuations and flicker

In accordance with the regulations of the EU guidelines

73/23/EWG (electrical operating equipment/low-voltage guidelines)

89/336/EWG (electromagnetic compatibility)

Flawil, 05.03.2001

BÜCHI Labortechnik AG
Meierseggstrasse 40
9230 Flawil
Schweiz
Tel +41 (0)71 394 63 63
Fax +41 (0)71 394 65 65
buchi@buchi.com
www.buchi.com

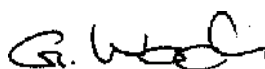

Guido Worch
Qualitymanager

